

Other functional fittings



Titus[®]

LAMA







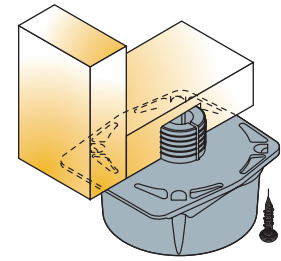

Adjustable cabinet leg range

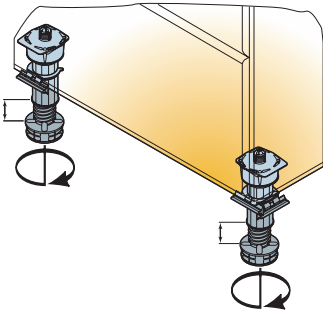
Leg top fixes

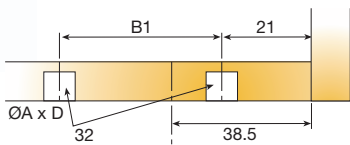
Technical and mounting details		A	D	Item number	Black
		Drilling diameter	Drilling depth		
Rivet fix	regular	15	12.5	02560 →	835
	heavy duty	15	12.5	02630 →	835
 					
 200 Pcs	Made of plastic				
Socket fix (knock in)		10	12.5	02558 →	835
 					
 200 Pcs	Made of plastic				
Socket fix (screw on)				02559 →	835
 					
 200 Pcs	Made of plastic				

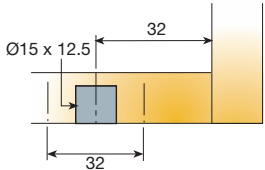
- Lip provides additional support to end panel and gives extra strength
- The side fix has twin dowel mounting for positive location
- Rivet fix design gives quick fastening of socket
- Choice of dowel or screw on sockets
- Invert second clip for corner plinth fixing

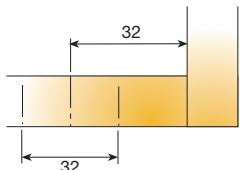









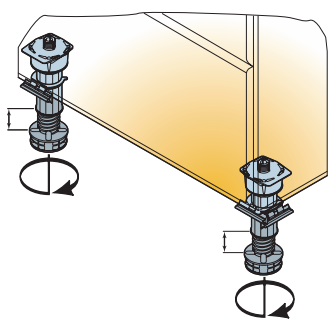

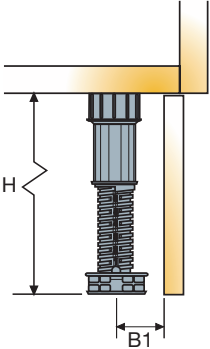
Technical and mounting details		A	D	B1	Item number	Black	
		Drilling diameter	Drilling depth	Drilling distance			
 <p>Technical and mounting details</p>	Leg top (4 screws) screw on	3	6	64 x 64	02575 →	835	
		(4 dowels + lip) dowel/lip	10	12.5	64 x 64	02582 →	835
		(4 screws + lip) screw/lip	3	6	64 x 64	02579 →	835
	2 dowels/2 screws	10/3	12.5/6	64 x 64	*02669 →	835	
	screw on	3	6	64 x 64	*02671 →	835	
	dowels	10	12.5	64 x 64	*02672 →	835	
		<i>* Asian market only</i> When using leg top, you must use foot with 01373 clip → see page 7.6					
 100 Pcs	Made of plastic						
Rivet fix/skid			02663 → 835				
 200 Pcs	Made of plastic						
Rivet fix/ no rivet			*02642 → 835 <i>* Asian market only</i>				
 200 Pcs	Made of plastic						

Adjustable cabinet leg range

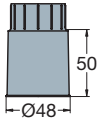
Adjustable leg, extension and foot

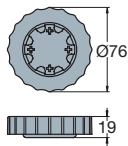







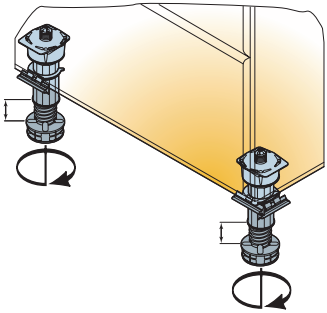

- Legs are supplied assembled at a pre-set height
- Wide adjustment range to fit all common plinth heights
- Jacking point adjustment feature
- Simple push on design to sockets

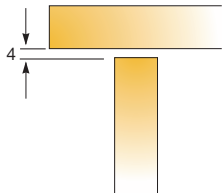
 Technical and mounting details		B1	H	Item number	Black
		Drilling distance	Fitting height adjustment		
Adjustable leg  		24	60-90	02570 →	835
		24	92-152	02549 →	835
		24	92.5-150	02666 →	835
		24	92-150	*02648 →	835
		24	125-185	*02653 →	835
	big foot	38	92-150	*02699 →	835
	big foot	38	125-185	*02706 →	835
	big foot	38	110-170	*02645 →	835
	<i>* Asian market only</i>				
	 100 Pcs (02570)  200 Pcs Made of plastic				
Leg extension  				02571 →	835
 200 Pcs Made of plastic					
Fixed foot  				02569 →	835
				*02574 →	835
 200 Pcs Made of plastic	<i>* American market only</i>				

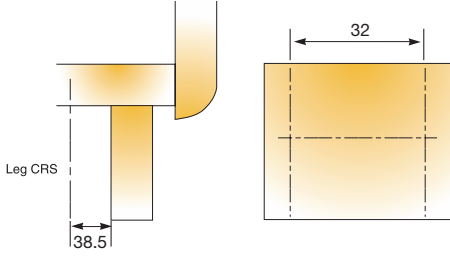
Adjustable cabinet leg range

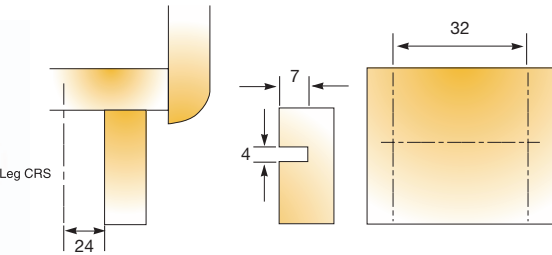
Plinth clips and fox clip

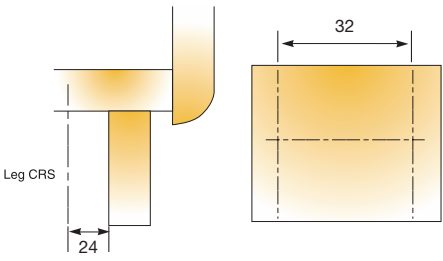
- Spring design eliminates the need for drilling and fits into any position on plinth
- The screw in version can sit in variable plinth positions
- When taking plinth around the corner, the fitting is reversible.

		Item number	 Natural
Technical and mounting details			
Fox clip  	 1000 Pcs Made of plastic	01373 → 846	
Plinth clip 38 screw  	 500 Pcs Made of plastic	02578 → 835 *02710 → 835 * Asian market only	
Plinth clip 24 knock on  	 600 Pcs Made of plastic	02523 → 835	
Plinth clip 24 screw on  	 600 Pcs Made of plastic	02634 → 835	

Hinge solutions

Glass door hinge

- Hinge, grub screws and mountings are supplied as a kit
- One piece moulding
- The closed end on the hinge provides a foolproof location of hinge to edge of glass
- All plastic design is safer in contact with glass

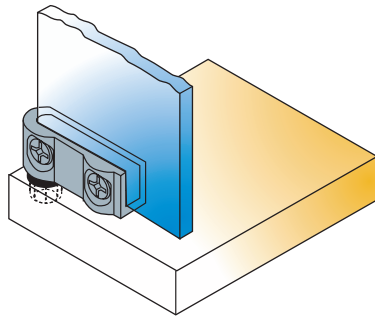

Technical and mounting details

Item number

Black

Glass door hinge set

04266 →

835

One set consists of:

- 2 pcs hinge assembly
- 1 pcs handle plate
- 1 pcs pad for handle
- 2 pcs hinge adhesive pad

Other colours on request



Hinge assembly

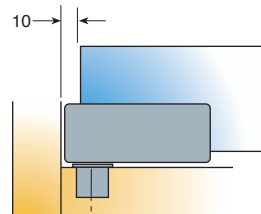

Handle plate for magnetic catch

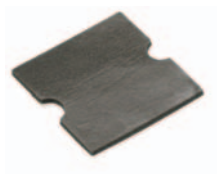
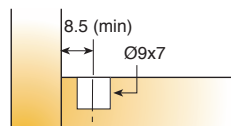

Pad for handle

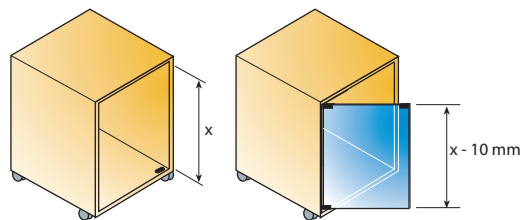

x = internal height



Hinge adhesive pad

250 Pcs

Made of plastic

Hinge solutions

Hold-shut glass door hinge

- Hold feature keeps door in closed position
- The grub screws have flange to prevent overscrewing resulting in an accurate fit every time
- No requirement for an adhesive pad
- Kit of parts is ordered as a single part number

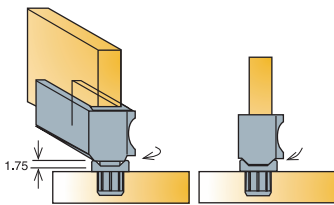

Technical and mounting details

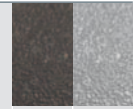

Item number

Black

Silver

Set for
3-4 mm glass

04452 →

835

861

One set consists of:

- 1 pcs handle and door stop
- 2 pcs hold shut GDH set
- 1 pcs hold shut accessory set

Other colours on request



Handle and door stop

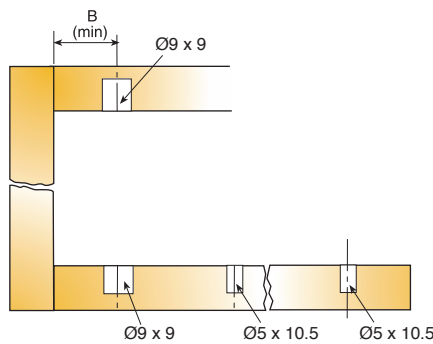

Hold shut GDH set



Hold shut accessory set

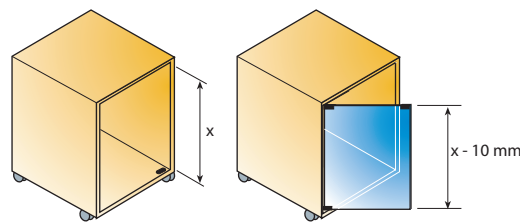









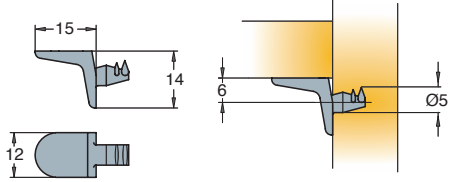
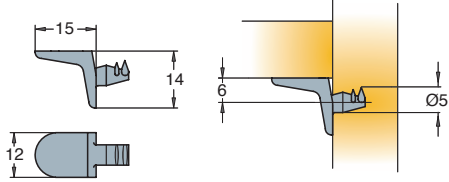
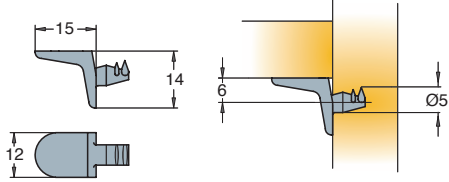
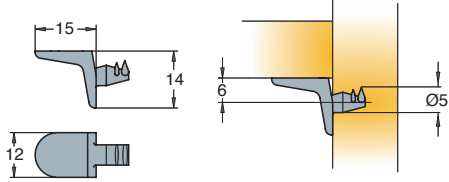

x = internal height

250 Pcs

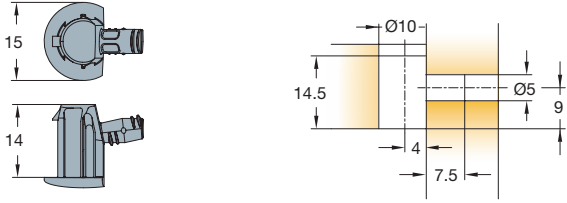
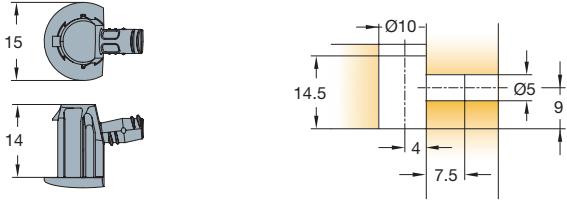
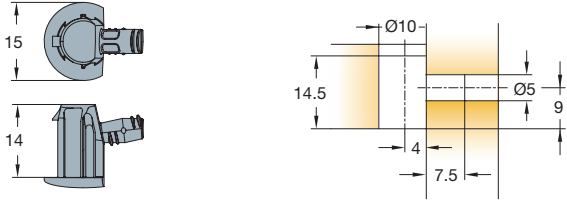
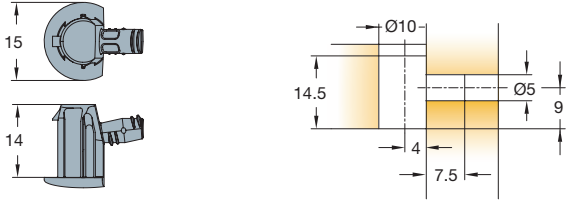
Made of plastic

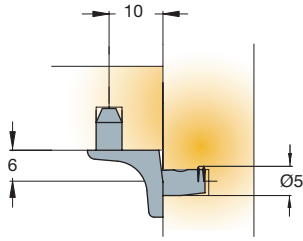
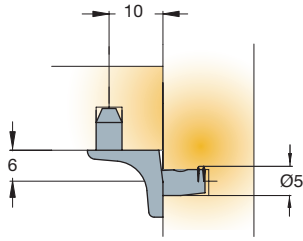
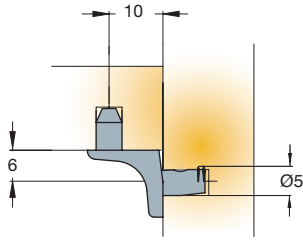
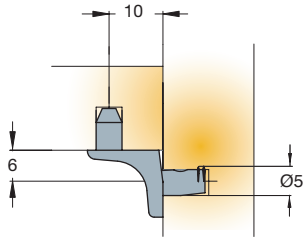

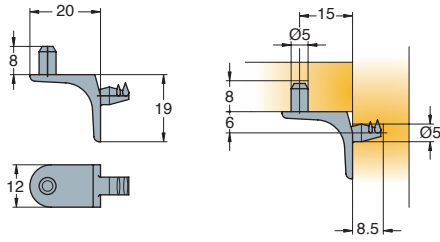
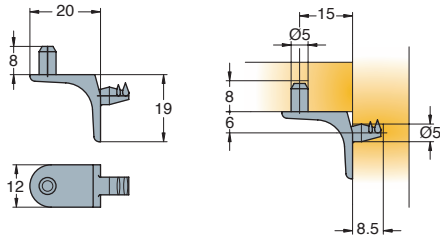
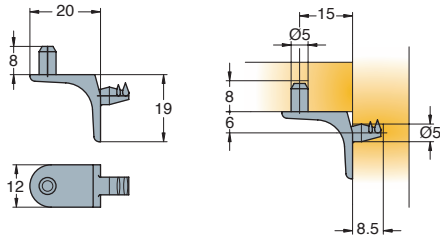
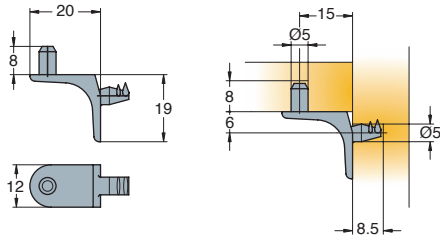



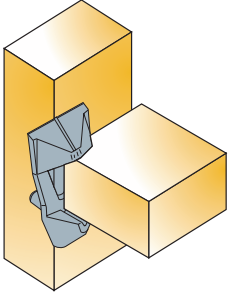

Shelf supports

- Shelf supports are made of zinc, steel or plastic
- Teeth on mounting pin prevent rotation and fall-out of the fitting
- Screw-on and glass shelf versions are available

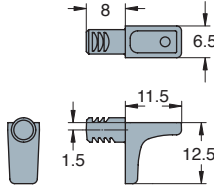
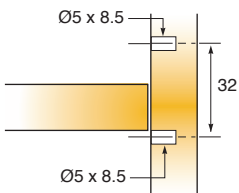
Technical and mounting details		Item number	Nickel plated	Zinc
Without pin (rock-in)  		336.3553. → 650		
			014952 → 170	
 1000 Pcs (336.3553.)  4000 Pcs (014952) Made of zinc				
Structural shelf support  		*01851 → 847 885		
			<i>* American market only</i>	
 3000 Pcs Made of zinc				
2 pins (rock-in)  		014953 → 170		
				
 3000 Pcs Made of zinc				
Pin Ø5x8 (rock-in)  		336.3174. → 650		
				
 1000 Pcs Made of zinc				

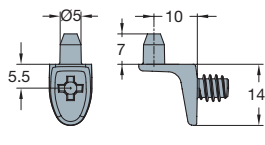
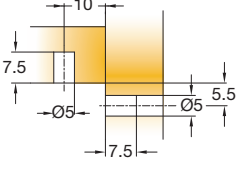
Shelf supports

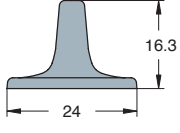
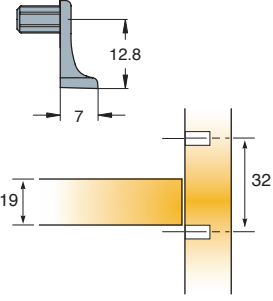

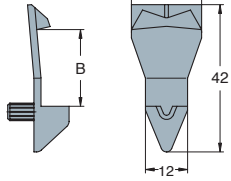
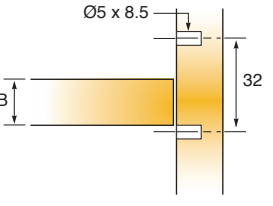

- Hold down feature traps the shelf in place for security
- Folding design allows the shelf to be post mounted in an assembled cabinet
- To suit a wide range of shelf thicknesses
- Pad for metal shelf support when using glass

						
		Item number	Black	Nickel	Zinc	White
<p>Technical and mounting details</p>						
<p>Shelf support (push-in)</p>  <p>2000 Pcs</p>	 <p>Made of zinc</p>		<p>01825 →</p>	<p>847</p>	<p>885</p>	
<p>Shelf support (push-in)</p>  <p>2000 Pcs</p>	 <p>Made of zinc</p>		<p>01852 →</p>	<p>847</p>		
<p>Shelf holddown (for use with 01825)</p>  <p>7000 Pcs</p>	 <p>Made of plastic</p>		<p>01822 →</p>		<p>861</p>	
<p>Shelf support retainer</p>  <p>4000 Pcs</p>	 <p>Made of plastic</p>		<p>15</p>	<p>01837 →</p>	<p>835</p>	<p>877</p>
			<p>16</p>	<p>01838 →</p>		<p>877</p>
			<p>19</p>	<p>01843 →</p>		<p>877</p>
			<p>16</p>	<p>*01828 →</p>		<p>877</p>
			<p>19</p>	<p>*01829 →</p>		<p>877</p>
<p><i>* American market only Other colours on request</i></p>						

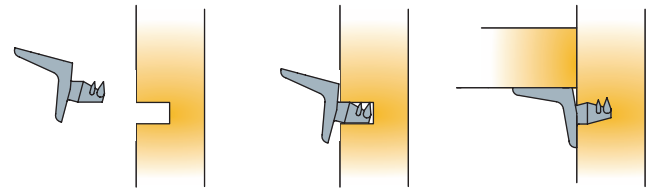

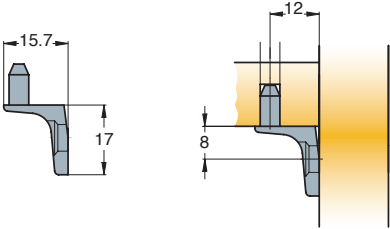

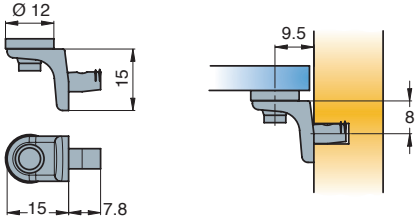
Shelf supports

Mounting procedure:



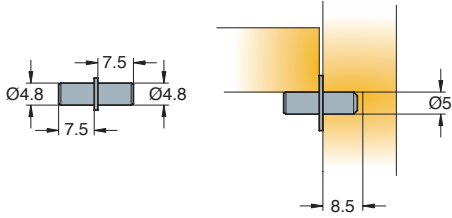

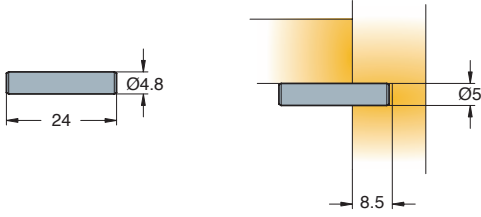
Technical and mounting details	Item number	Zinc plated blue Nickel plated
<p>Pin Ø5x10 (screw-on)</p>   <p>1000 Pcs Made of zinc</p>	338.3687. →	650
<p>For glass shelves (rock-in)</p>   <p>1000 Pcs Made of zinc and plastic</p>	338.9721. →	860
<p>Pin Ø5x10 (rock-in)</p>   <p>1000 Pcs Made of zinc</p>	338.3686. →	650

Shelf supports

Technical and mounting details		Item number	Zinc plated blue	Nickel plated	Antique brass plated
Pin	 	334.6073. →	040	050	
	 5000 Pcs Made of steel				
Pin	 	335.6076. →	040	080	
	 5000 Pcs Made of steel				

Connection with M4 screws

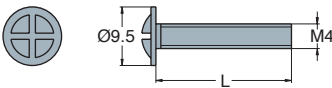
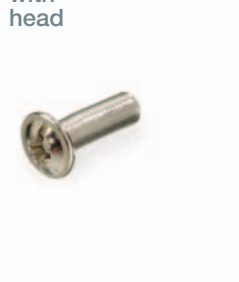
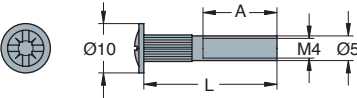
Connecting screws

		A	L	Item number	Zinc plated blue	Nickel plated	
Technical details							
Connecting screw 			17	830.6215. →	040		
			20	830.6216. →	040		
			22	830.6217. →	040		
			25	830.6218. →	040		
			28	830.6219. →	040		
			38	830.6261. →	040		
			30	830.6273. →	040		
			32	830.6274. →	040		
			35	830.6292. →	040		
			40	830.6275. →	040		
			42	830.6276. →	040		
		 10000 Pcs	Made of steel				
Sleeve with head 			10	13	270.6531. →	050	
			12	15	270.6532. →	050	
			15	27	270.6533. →	050	
 5000 Pcs	Made of steel						

No-tools Backfix and Trimfix™

- Push Backfix into panel
- No tools required to lock the Backfix panels together
- The handle on Backfix acts as a stop during locking, providing greater accuracy and speed of insertion
- Barbs on the Backfix provide a quality fastener for rigid cabinet construction

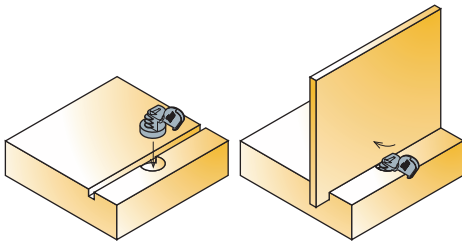

Technical and mounting details

Item number	Zinc	Corrosil	Phosphate
	Zinc plated		

Hardboard Backfix

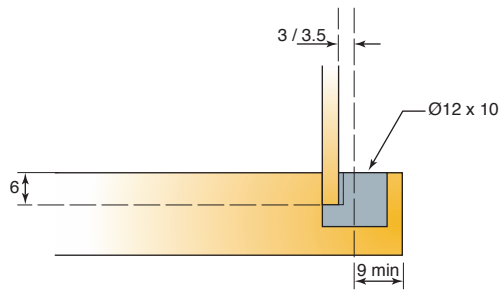

1000 Pcs

Made of zinc

02154 → 885 897

Trimfix™

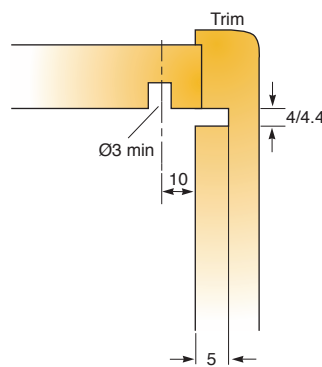

2000 Pcs

Made of various material

01370 → 852 833

Screw panhead No 8 x 17.6



15000 Pcs

Made of zinc

*01709 → 883

Glass clip

Rear wall connectors

		Nickel plated	Zinc plated	Transparent	Antique brass plated
<p>Drawing shows glass clips mounting example.</p>	<p>Technical and mounting details</p>	L			
		Pin length	Item number		
Glass clip 		3.3	359.4201. →		340 370
		6	359.4302. →		340
		9.5	359.4223. →		340 370
25000 Pcs	Made of plastic				
Rear wall connector long 			011608 →	170	
			04801 →	847 883	
1000 Pcs	Made of zinc				
Rear wall connector short 			016554 →	170	
1000 Pcs	Made of zinc				
Rear wall connector 			04.2658.001. →	001	
			04.2658.001. →		002
500 Pcs	Made of zinc				

Panel brackets

- To be used to fix face frames to carcasses without additional drilling to cabinet
- Designed for carcase side panel of 18mm thickness
- Edge to hole centre = 28mm
- Easier fixing of frames due to parts that remain in holes once inserted

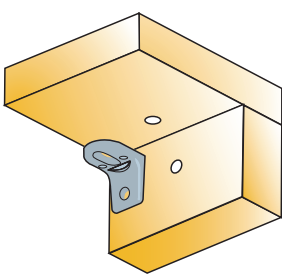
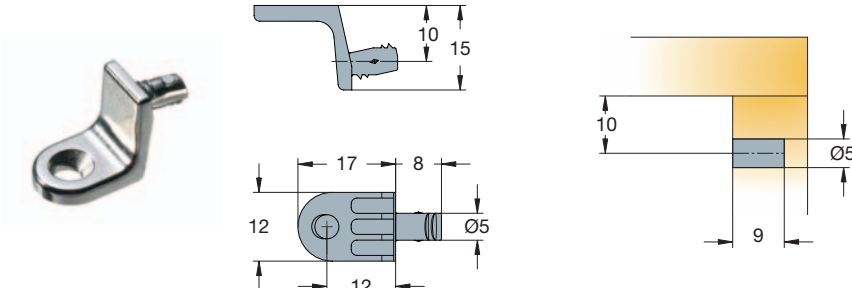
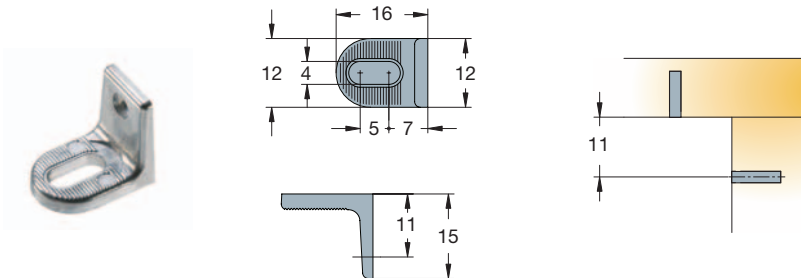
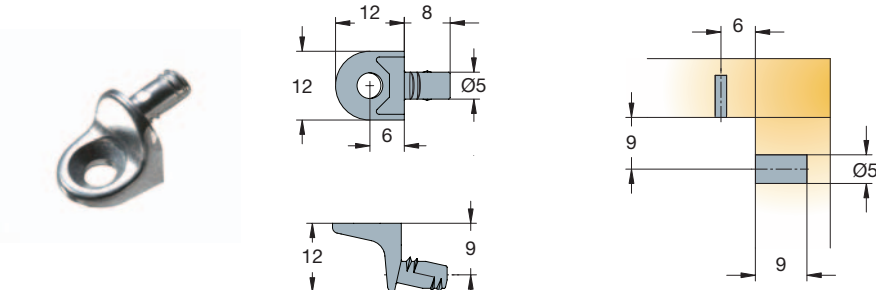
 <p>Technical and mounting details</p>	<p>Item number</p> <p>Nickel plated</p> <p>Zinc</p>
<p>90° Bracket (screw-in/rock-in peg)</p>  <p>1000 Pcs Made of zinc</p>	<p>02111 → 847 885</p>
<p>90° Bracket (screw-in)</p>  <p>1000 Pcs Made of zinc</p>	<p>02110 → 885</p>
<p>Corner bracket (rock-in)</p>  <p>1000 Pcs Made of zinc</p>	<p>02133 → 885</p>

Wardrobe rail

Rail supports

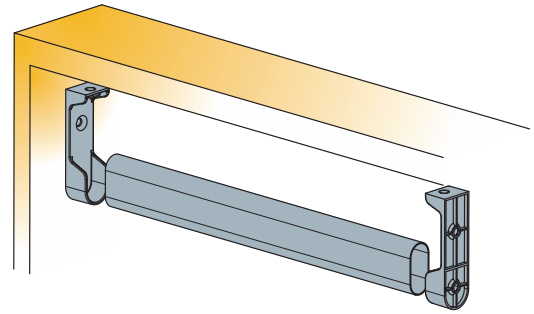

Technical and mounting details

Item number

Chrome plated

Nickel plated

Rail



10 Pcs

Made of chrome plated steel

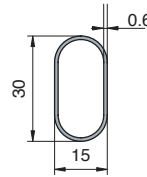

339.7047. → 060

Standard length 3m

Standard length is 3m.
Other lengths available upon special request → see page 0.3

Rail support 3-holes



1000 Pcs

Made of zinc

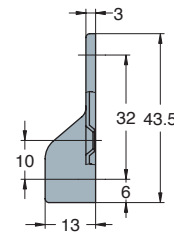

015130 →

170

Rail support 2-pins



800 Pcs

Made of zinc

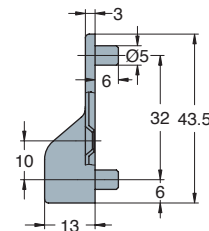

015129 →

170

Rail support M6



350 Pcs

Made of zinc

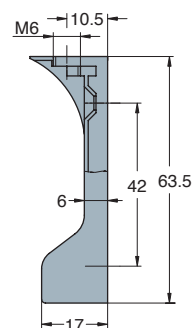







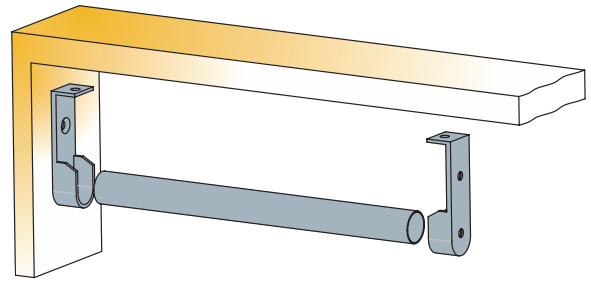

015128 →

170

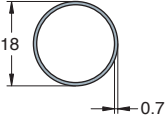
Wardrobe rail

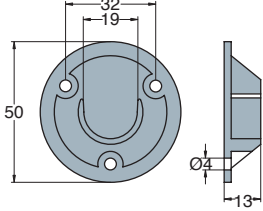
Ø18

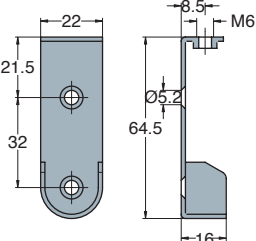

Technical details		Item number	Chrome plated	White	Brown	Nickel plated
Rail	 	339.7044 → 350 370 339.7041 → 060				
 10 Pcs	Made of steel, chrome plated or plastic coating	Standard length is 3m. Other lengths available upon special request → see page 0.3				
Screw-on	 	337.4059. → 350 370				
 2000 Pcs	Made of plastic					
Screw-on under a shelf	 	337.1398. → 050				
 250 Pcs	Made of steel	M6 screw supplied separately: 815.6354. 040  1000 Pcs				