

Cabinet Connectors

Cabinet Connectors

Product Guide

Page

System 1

Fittings for rigid assembly systems

a highly cost-effective and rigid assembly system for factory, consumer and home assembly

1.9

System 2

Fittings for face-boring applications

face boring applications that provide a tolerant efficient assembly

1.11

System 3

Fittings for face and edge boring

two component rigid face and edge drilling fastening

1.13

System 4

Fittings for face-boring only

a range of low-cost one-piece fittings for high volume home assembly applications

1.15

System 5

Cams and dowels

a comprehensive range of cam and dowel connecting fittings for all cabinet applications

1.21

System 6

Quickfit-Expando connectors	face boring expanding connectors for all cabinet applications	1.45
-----------------------------	---	------

System 6.2

Expando connectors for face boring	face boring connectors for closets and wardrobes	1.57
------------------------------------	--	------

System 7

Heavy duty cams and dowels	high quality fittings for offices and public furniture	1.67
----------------------------	--	------

Cabinet Accessories

Complementary and structural support fittings	Shelf Q-Peg	1.73
	Shelf supports	1.74
	Joining plates	1.77
	Backfix	1.78
	Back wall connectors	1.79
	Panel brackets and wall connectors	1.80
	Adjustable cabinet legs	1.81
	Drawer front adjuster	1.85

Connectors

Information

Why Choose Titus?

Titus connectors add value to furniture and to furniture manufacturing

Titus connectors improve the quality of furniture and lower the cost of manufacturing and assembly while ensuring a high degree of customer satisfaction.

The most advanced range of connectors available on the market

Precise and efficient product design. **The broadest possible range of drilling tolerances** ensures reliable assembly and consistently strong joints. **'Klix'** locking feature, the engagement of interlocking teeth on cam and dowel, to prevent joint loosening in service or transit.

Expanding function provides degrees of variation in out-of-tolerance drillings ensuring stronger joints and improved quality of furniture.

Twinstart thread for faster and more stable insertion.

Depth stop collar prevents over-insertion.

Firm tightening for greater confidence in use.

Cam locks at 230° assuring smooth tightening action and greater dowel pull-up.

Quickfit for hand dowel insertion.

Quickfit TL5, new generation steel dowel with quickfit expando technology for insertion in Ø5mm dowel holes.

Quickfit TL2, TL4 with the built-in self adjustment feature for higher drilling tolerances.

Quickloc one piece fitting for faster assembly with integrated expanding cam and dowel.

Zinc+steel dowel for optimal strength and performance.

Precise dowel manufacturing high precision of zinc and strength of steel assures 100% dimensional accuracy.

Easy and quick consumer friendly self-assembly of furniture

Self-assembly furniture offers consumers good value and instant availability of products.

With the aim of providing consumer with simpler instructions, fewer parts and an easier assembly process, Titus has significantly reduced and simplified the number of fittings traditionally required in furniture production.

Titus connectors provide consumers with easy assembly and furniture producers with increased productivity:

- reduced number of assembly parts
- easy assembly instructions
- security of packed parts during transit

CAF Quick & Easy

Consumer Assembly Friendliness

Easy and Quick Furniture Assembly

CAF formula

CAF=Consumer Assembly Friendliness

Titus CAF formula provides a comparative measure for customer satisfaction. By using it manufacturers are able to evaluate their products internally or against those of their competitors.

While offering consumers easier and faster assembly, there are obvious advantages also for furniture manufacturers – buying, counting, bagging and stocking of fittings can be greatly reduced.

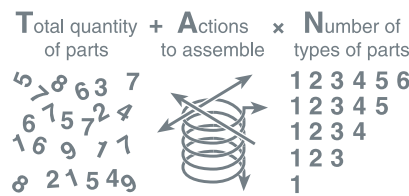

$$(T+A)N = CAF$$

Minimise the numbers in the Titus CAF™ formula to achieve:

- High customer satisfaction
- Improved productivity
- Higher profits

How does it work?

Comparative CAF scores to assemble a hand held demonstrator

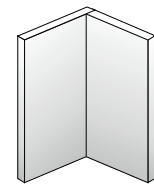

	T	A	N	CAF
Connecting screw (traditional assembly)	4	38	3	126
Cam & dowel with single start thread	6	21	4	108
Cam & dowel with twinstart thread	6	15	4	84
Cam & TL2 dowel (self-assembly)	6	7	4	52
Cam & TL2 dowel (factory pre-inserted)	2	3	2	10
Quickloc	2	3	1	5
Fully assembled demonstrator	1	0	1	1

Cabinet Connectors

CAF Quick & Easy

Consumer Assembly Friendliness

Consumer Assembly Friendliness - CAF principle

- Quick assembly with less parts and less assembly steps
- Simple instructions
- Easy and intuitive assembly

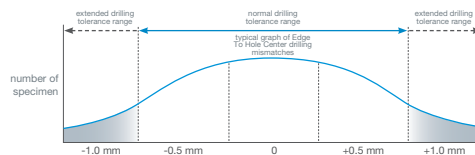

High drilling tolerances

- Optimal cabinet joint even in cases of inaccurate drilling
- In-built self adjustment feature ensures perfectly aligned and precise joints

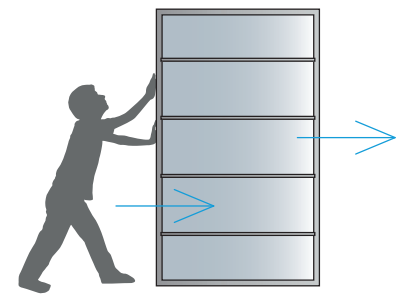

Strong and reliable joints

- High performance joints
- Great cabinet strength even at repeatable assembly or disassembly
- Enhanced resilience even in more demanding applications in tall wardrobes or office furniture

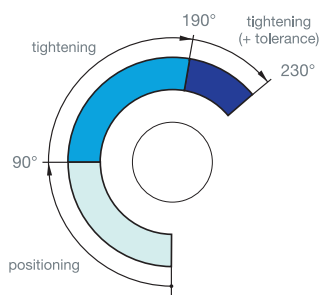

Reliable and comfortable locking

- Smooth and firm tightening at 2 o'clock lock
- Great dowel pull-up for optimal performance
- Strong and reliable joint

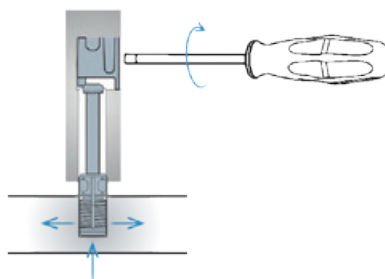

Expando function

- Expanding sleeve on dowels assures high resistance to pull-out
- Firm fixing in the dowel hole

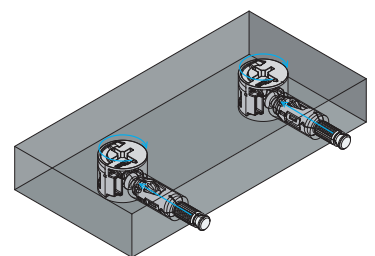

Factory pre-insertion

- With Quickfit TL5 and TL2 dowels
- Perfect for RTA market: easier packing and transportation
- The insertion of cams and dowels can be automated using Lama FastFit machine

System 1

Fittings for Rigid Assembly Systems

System Features

Double locking carcass screw

- Zinc diecast for precision
- Titus Double locking carcass screw makes an almost invisible connection
- Collar under the head to pull panels together
- 2nd 'lower' thread pulls against a 'faster' thread to provide maximum connection force and prevents overdriving of fastener
- Almost invisible in position
- Head can be 'fastcapped' or filled

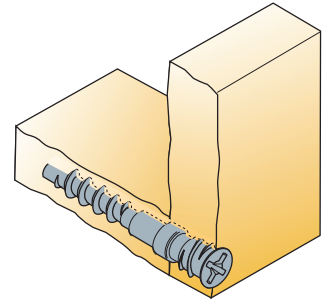

System 1

Fittings for Rigid Assembly Systems

Double Locking Carcase Screw

- High performance from widely spaced primary thread
- Finer secondary thread provides additional holding power and positive stop (no override)
- Increased support for vertical panel is gained from the funnel head with collar at its base
- One-piece fitting

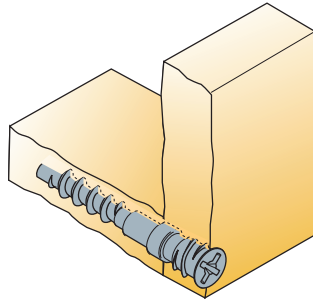

Technical and mounting details

Item number

Zinc

Screw 6x42

00180

885

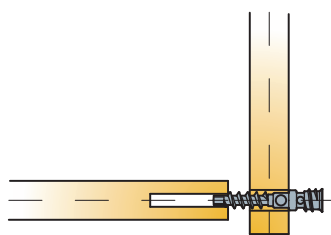
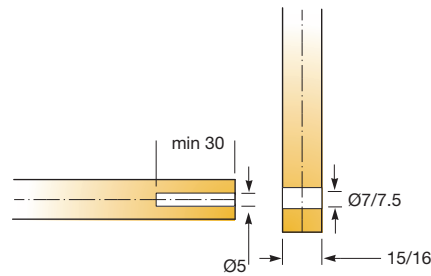
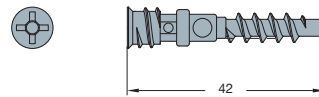

1. Insert screw to shoulder in face board

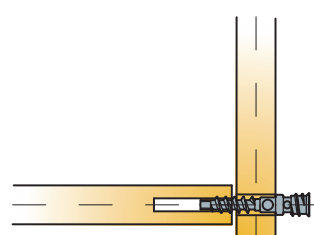

2. Screw into Ø5mm hole

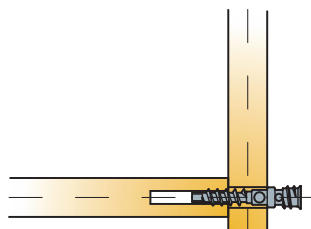

3. Board joint pulled up by collar on screw

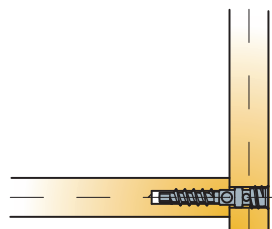

4. Board locked in place by screw

1000 Pcs

Made of zinc

System 2

Fittings for Face-boring Applications

System Features

A family of face boring only fasteners with wide tolerances and the high clamping force of an angled screw.

- Factory or site component installation
- Wide tolerances
- Face boring only
- For kitchen, furniture storage, office and store fixture applications
- Non twist rail fastener versions
- Screw fastening or hammer insertion

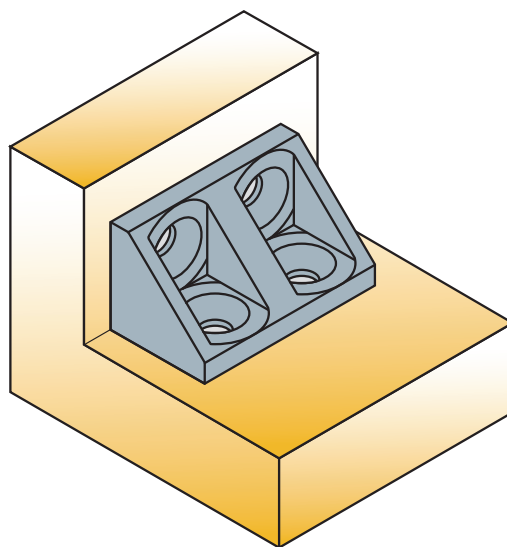

System 2 Fittings for Face-boring Applications

- Range of fixing blocks for multiple applications
- Face drilling only required
- Durable plastic material is flexible providing greater holding power
- Choose screw fastening or hammer insertion

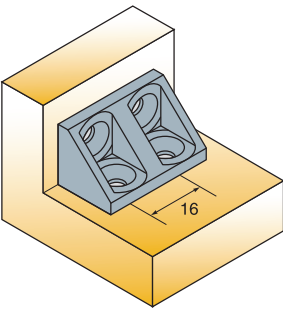

Technical and mounting details

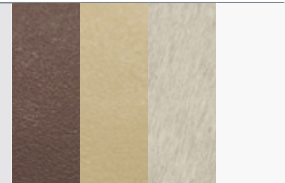

Item number	Dark brown	Light brown	Ivory	White
-------------	------------	-------------	-------	-------

Rail fastener

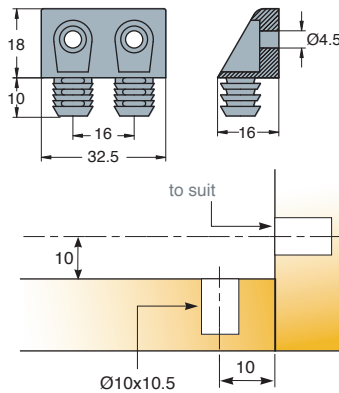

02075 →	831	867		877
---------	-----	-----	--	-----

2000 Pcs

Made of plastic

Housing (no nose)

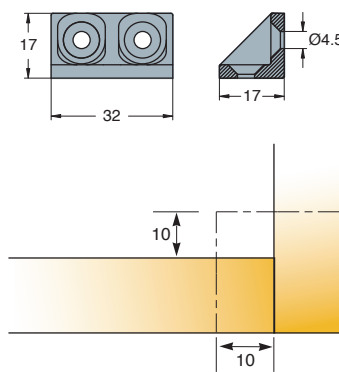

02077 →			875	877
---------	--	--	-----	-----

2000 Pcs

Made of plastic

Modesty block

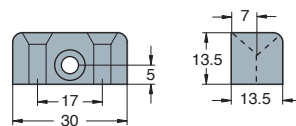

*06073 →		867		877
----------	--	-----	--	-----

*European market only

1500 Pcs

Made of plastic

System 3

Fittings for Face and Edge Boring

System Features





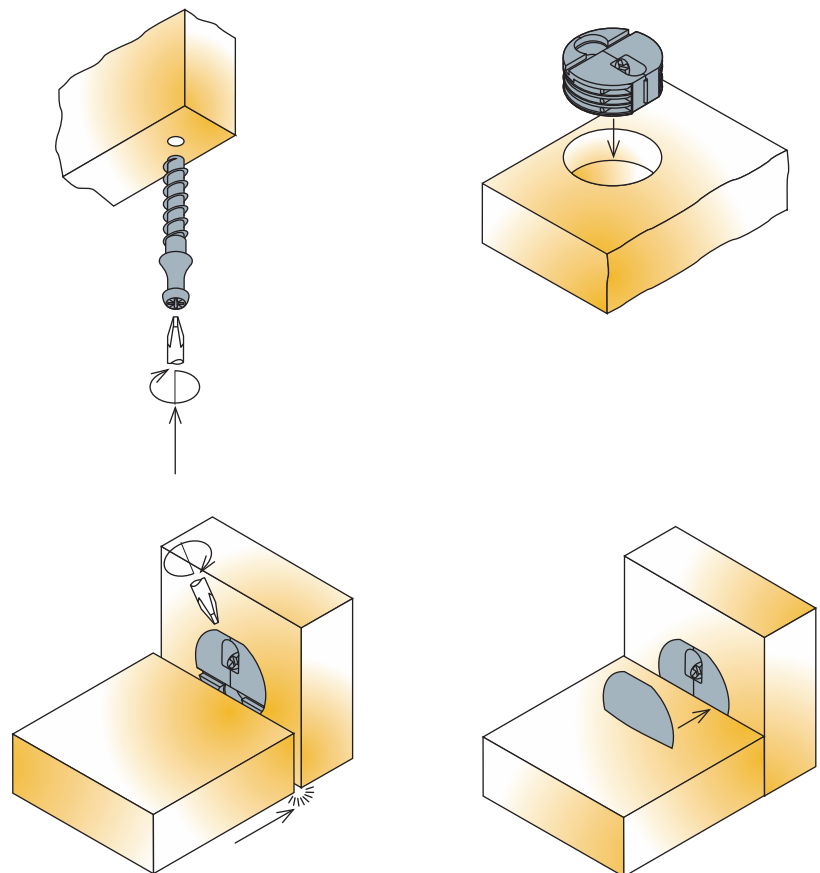

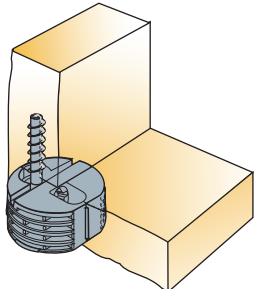

Titus System 3 is a two component rigid face and edge drilled fastening with half turn to fasten. System 3 offers almost full concealment and wide tolerances in use.

- Automatic or in-factory placement
- Pre-location pin ensures ease of assembly
- Less than one turn of a screwdriver to fasten
- Shelf edge installation of pin means maximum shelf cut size tolerance
- Can be used on 12mm shelf panels
- No loose parts for maximum convenience in RTA
- Drawer front fixing, cabinet construction

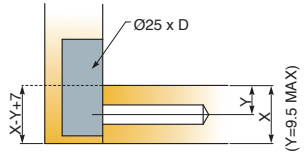

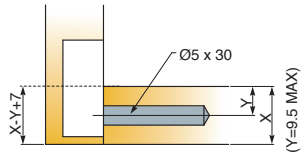
System 3 Fittings for Face and Edge Boring Concealed Housing

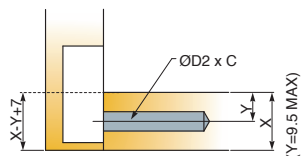
- One turn locking system reduces assembly time, both in the factory and home
- Pre-assembly feature for consumer convenience
- Choice of dowels to suit drilling
- Hi-Lo screw feature for faster insertion

Technical and mounting details		C	D	D2						
		Drilling length for dowel	Drilling depth for housing	Drilling diameter for dowel thread	Item number	Black	Zinc plated	Dark brown	Yellow passivate	White
 <p>Technical and mounting details</p>										
Housing assembly  <p>X, Y - depends on board thickness</p>  <p>Made of plastic or zinc, plastic</p> <p>2500 Pcs</p>		12.5		03118 →	835		831		877	
<i>Other colours on request</i>										
Screw dowel Ø5  <p>X, Y - depends on board thickness</p>  <p>Made of zamak</p> <p>1000 Pcs</p>		30		5	03168 →		883			
Screw dowel Ø3  <p>X, Y - depends on board thickness</p>  <p>Made of steel</p> <p>5000 Pcs (03180) 4000 Pcs (03181) 1000 Pcs (03090)</p>		11		3.75	03181 →				881	
		9		3	03180 →				881	
		25		3	*03090 →		883			
<i>*American market only</i>										
Cover cap  <p>Made of plastic</p> <p>15000 Pcs</p>					03150 →	835				877

System 4

Fittings for

Face-boring Only

System Features

Cost effective one piece fittings with face boring benefits

- Flush and block components
- Face-boring only
- Good tolerances
- One piece connectors
- Angledriv versions fastening with maximum driving power and flexibility
- Quickloc™ versions need only one turn to tighten for fast assembly
- Foolproof consumer home insertion

Quickloc™ One-piece connector

The integrated housing and dowel make Quickloc™ the most user-friendly and tolerant product available.

- High degree of drilling tolerance
- Push-in design
- Tool-free insertion
- Integrated expanding housing and dowel provide consistently stronger joints
- 'Klix' locking system

Quickloc™ Assembly

1. Press Quickloc into the face board

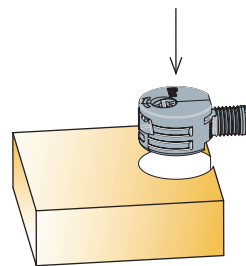

2. Assemble the panels

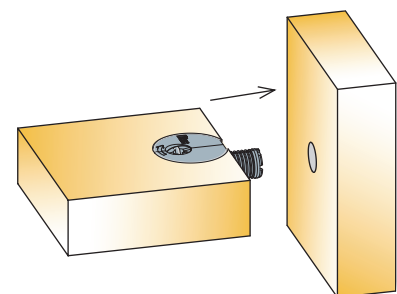



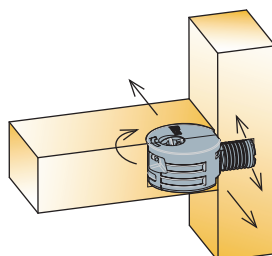





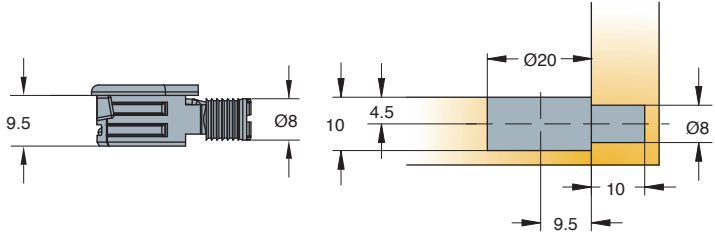

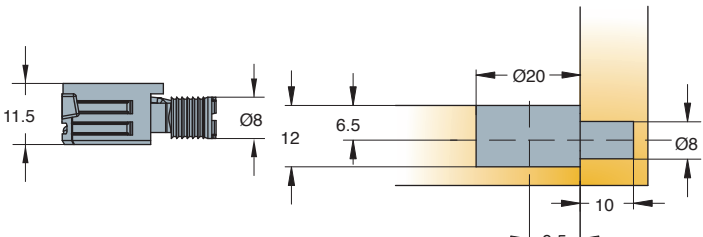
3. Tighten in less than one turn

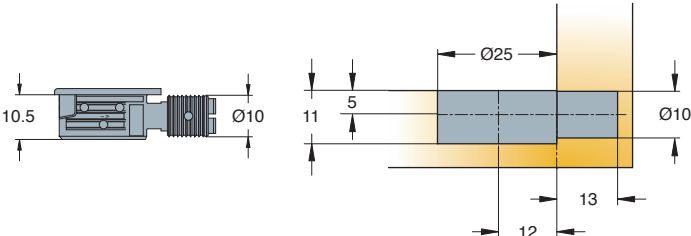

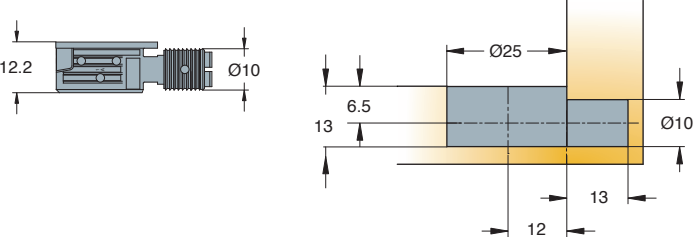
System 4 Quickloc™ One Piece Expanding Connector

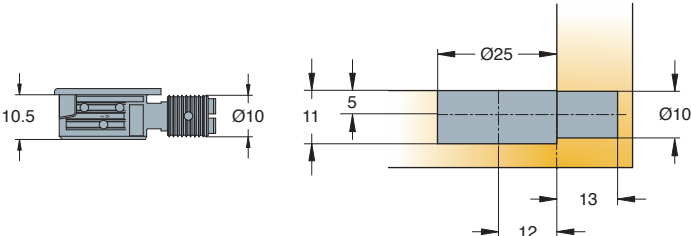
- An innovative, one-piece connector, capable of hand insertion
- Highly tolerant and tightens in less than one turn
- Face-bored product
- Offers a high degree of drilling tolerance and is the only connector of its type to provide pull-up of cabinet panels when tightened









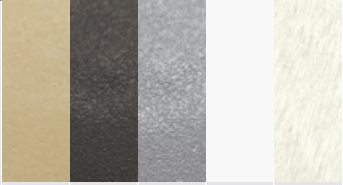
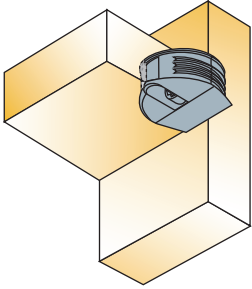

Technical and mounting details		Color options			
		Dark brown	Black	White	
		Item number	Dark brown	Black	White
Quickloc Ø20 flanged 		06803 →	831	835	877
 2500 Pcs	Made of zinc, plastic				
Quickloc Ø20 flush 		06806 →	831	835	877
 2500 Pcs	Made of zinc, plastic				
Quickloc Ø25 flanged 		06802 →	831	835	877
 1500 Pcs	Made of zinc, plastic				
Quickloc Ø25 flush 		06839 →	831	835	877
 1500 Pcs	Made of zinc, plastic				

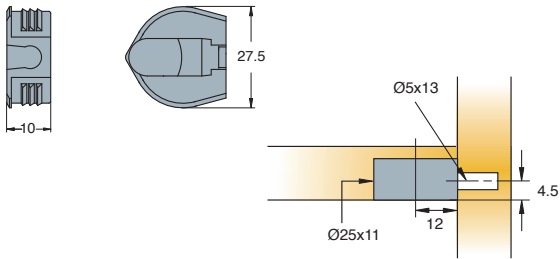
System 4

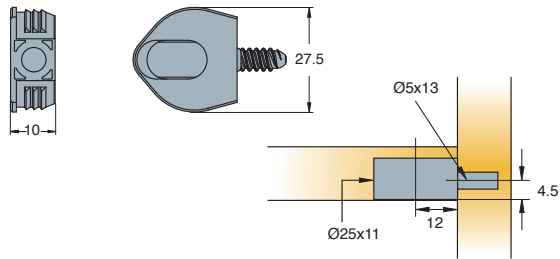
Fittings for Face-boring Only

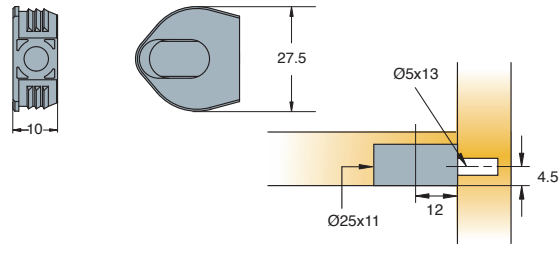
Flushbloc™ / Flushfix™

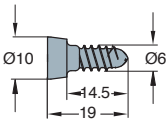
- The Angledriv screw provides high level of tolerance
- Face drilling only required
- Corner joint and shelf fixing options

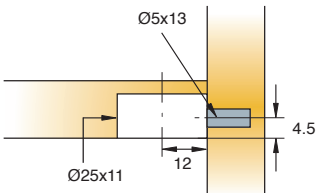
						
		Brown beige	Black	Silver	White	Zinc
Technical and mounting details		Item number				
						
Flushfix™ 		02161 →	806	861	877	
 2500 Pcs		Made of plastic <i>Other colours on request</i>				
Flushbloc™ with screw 		02193 →		835	877	
 2000 Pcs		Made of zinc and plastic <i>Other colours on request</i>				
Flushbloc™ assembly 		*02190 →		835	877	
 2500 Pcs		Made of plastic <i>* American market only</i> <i>Other colours on request</i>				
Angledrive screw for use with Flushfix™ 		00021 →				885
		00022 →				885
 2000 Pcs		Made of zinc 				

System 4 Fittings for Face-boring Only

Minibloc™ / Twinbloc™

- One-piece connector range
- Face drilling only required
- Easy to use, foolproof home insertion
- Angledriv screw tolerates good levels of inaccurate drilling increasing consumer confidence

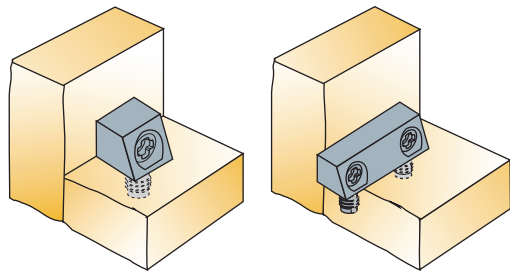

Technical and mounting details

Minibloc Ø10

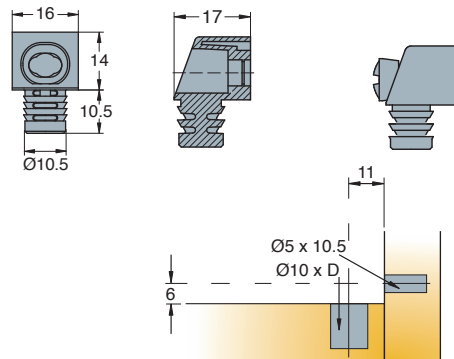

2500 Pcs (02107)
3000 Pcs (02120)

Made of zinc, plastic

Minibloc Ø8

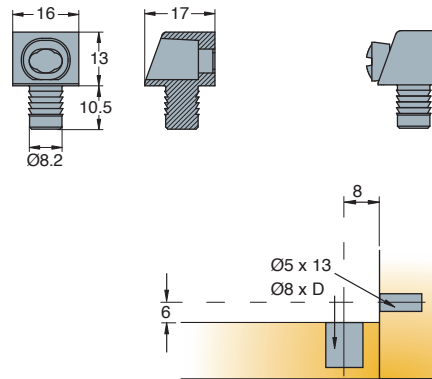

3000 Pcs

Made of zinc, plastic

Twinbloc Ø10

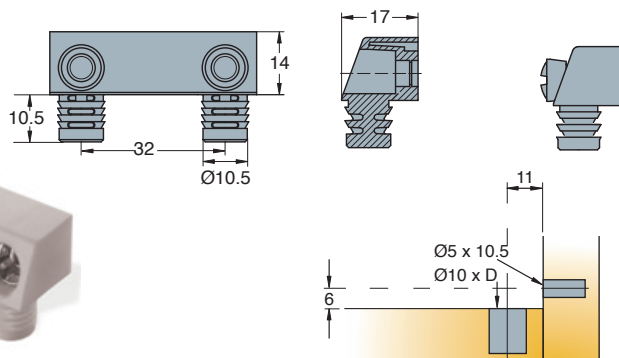
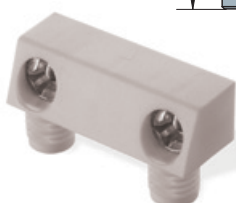

1000 Pcs

Made of zinc, plastic

Drilling depth	Item number	Colour			
		Dark brown	Black	Silver	White
11	02107 →	831	835	861	877
11	*02120 →	831	835	861	877
* Assembly with screw Other colours on request					
11	02141 →		835	861	877
11	*02144 →		835		877
* Assembly with screw * European market only Other colours on request					
11	02130 →		835	861	877
11	*02139 →		835		877
* Assembly with screw Other colours on request					

System 4 Fittings for Face-boring Only Cambloc

- Screw-on and knock-in versions are available
- Plastic housings are available in different colours
- Quick and intuitive assembly when fittings are pre-mounted on furniture

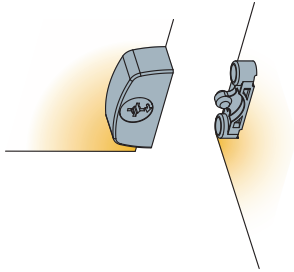

Technical and mounting details

Screw-on

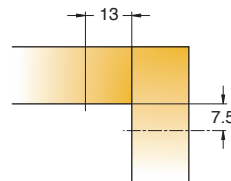
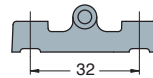
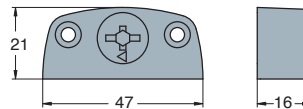

Item number

279-9187 →

Zinc plated
+ white housing

960

Zinc plated
+ brown housing

970

Zinc plated
+ black housing

980

 1000 Pcs

Made of plastic, zinc cam

System 5 Cams and Dowels

System Features

The most advanced cam and dowel range

Titus System 5 is a comprehensive range of cam and dowel connecting fittings with 'Klix' and Quickfit features for all cabinet applications: panel-to-panel, panel-to-hollow profile, back-to-back

Dowels

- **Quickfit TL5, 'Full metal jacket'**
a high performance Quickfit dowel for use in multiple wooden materials
- **Quickfit TL2, TL4, TL5 dowels**
a unique solution for factory pre-insertion, high level of drilling tolerances
- **Quickfit dowels**
quick hand insertion, easy assembly
- **Diecast dowels (zinc)**
precise manufacturing, optimal shape and design
- **Turned dowels (steel)**
'traditional' design, smooth surface, best strength performance
- **Combi dowels (zinc and steel)**
high precision of zinc, strength of steel, 100% dimensional accuracy and optimal performance

Titus 'Klix'TM

Titus 'Klix' locking system ensures the engagement of the interlocking teeth on cam and dowel providing:

- vibration-proof joint
- rigid construction that will not loosen in service or transit

Dowel insertion time comparison

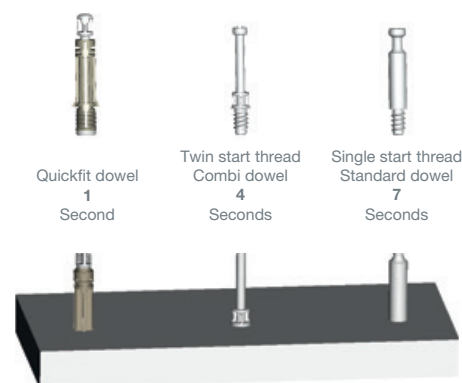

2 o'clock lock Smooth closing

Linear cam profile assures smooth, firm tightening action and greater pull-up. The cam always locks at 2 o'clock lock (230°), enabling greater consumer confidence in use while improving furniture quality.

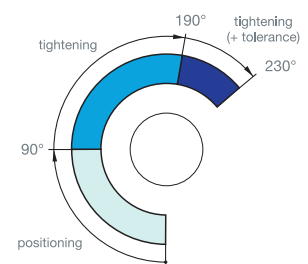

Drilling tolerances

Optimal performance and perfect joint even with inaccurate drillings.

Zinc/Combi dowel

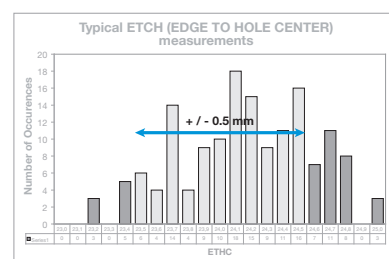
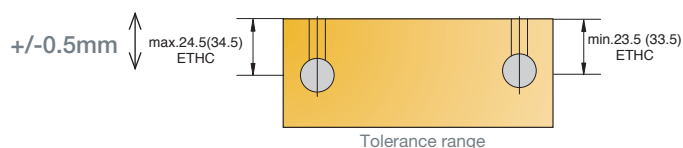

Quickfit TL5 dowel, Quickfit TL2 dowel

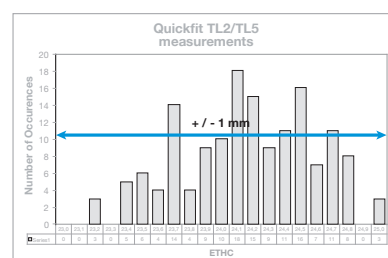
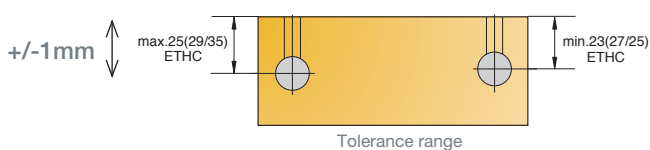

Quickfit TL4 dowel

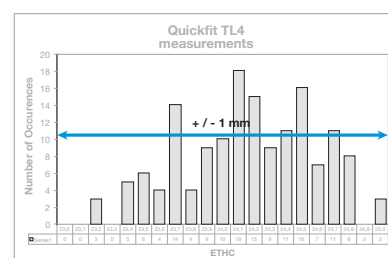
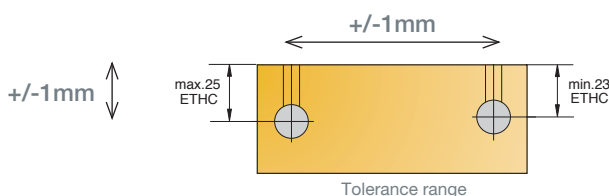

ETHC=Edge To Hole Center

Quickfit dowels for factory insertion

Quickfit TL5, Quickfit TL4, and Quickfit TL2 are the only dowel solutions designed for factory pre-insertion

- Optimised packaging processes
- Reduced risk of quality issues and claims
- Ideal for the RTA market

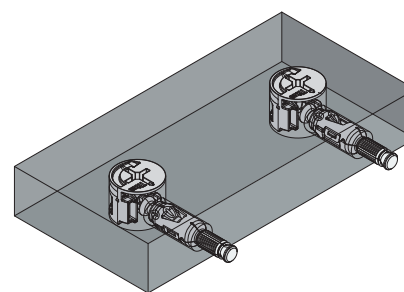

System 5 Cams and Dowels

Cam5000

Highly resistant joint for strong cabinet construction

Reinforced cam evenly engages the hole and prevents cam tilting and cam bursting.

Increased joint resistance enables effective performance in wider tolerance range.

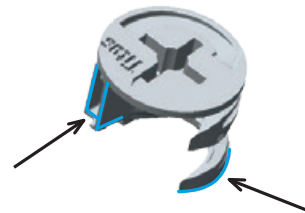

Linear cam profile

Linear cam profile ensures:

- Smooth tightening action
- Greater dowel pull-up



Cam retaining pips

Cam retaining pips ensures:

- The cam is held in position prior to assembly
- Secure cam positioning during transport and handling
- Accurate factory insertion



2 o'clock lock

Smooth and noticeable locking at the 2 o'clock position guarantees:

- always-right tightening for home assembly
- strong and rigid cabinet construction

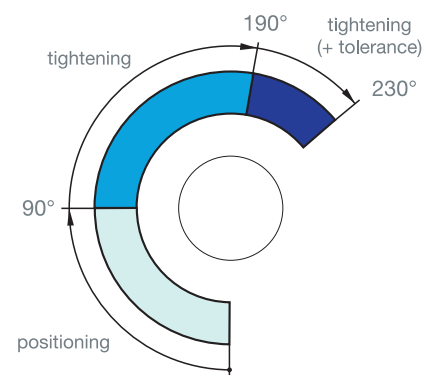

Optimised cam profile

Optimised cam profile ensures smooth and tight joint with no gap between panels.

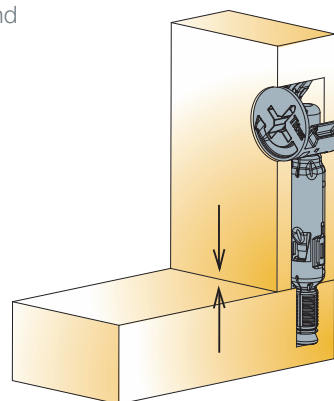

Optimal performance with all Titus dowels

Quickfit TL, Quickfit, Combi, end, double ended, angled and other screw-in dowels



System 5 Cams and Dowels

Quickfit Connectors

It is the fastest assembly system on the market. The Quickfit™ dowel may be inserted by hand, using only finger pressure. This eliminates the labour intensive process of screw-in assembly and the potential panel damage.

The Quickfit™ range of dowels has been extended to provide a complete family of fittings available in diameters of 5mm, 8mm, 10mm and lengths of 24mm and 34mm. These dowels are compatible with the range of Titus Ø15mm cams.

Assembly

1. Press the cam into face board

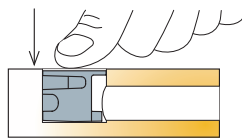

2. Insert the dowel into side panel

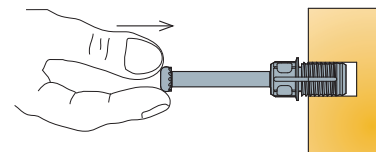

3. Assemble the panels

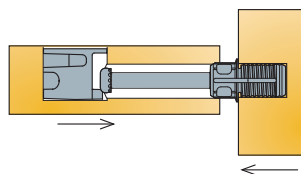

4. Tighten the cam to lock dowel

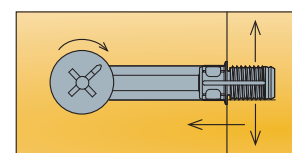
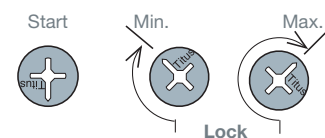

5. Assembled panels

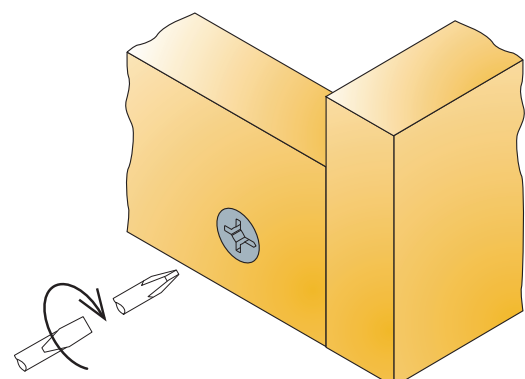

Quickfit TL Connectors

Quickfit-TL™ dowel offers furniture manufacturers a fast assembly system providing high drilling tolerances. It has a built-in self-adjustment feature, which enables common drilling inaccuracies to be overcome.

For the self-assembly furniture consumer, Titus Quickfit-TL™ is the most consumer friendly fitting on the market. Apart from the benefit of fully tightened joints and easy locking into the same position, Quickfit-TL™ provides an exceptionally smooth action when tightened, requiring very little effort.

Drilling tolerances

Marginal inconsistencies of drilling and the problems associated with the natural movement of wood panels, no longer present problems.

Quickfit-TL™ provides a tolerance of ± 1 mm on drilling operation while ensuring that the final result is a perfectly precise and aligned joint. No other assembly fittings system can offer such tolerances and still maintain a perfect joint.

Assembly

1. Press the cam into face board

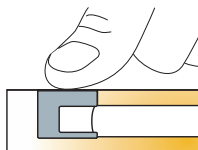

2a. Either push dowel into edge hole or...

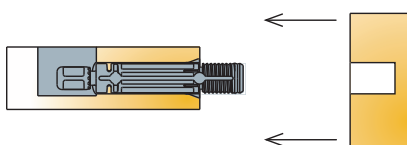

2b. Insert the dowel into side panel

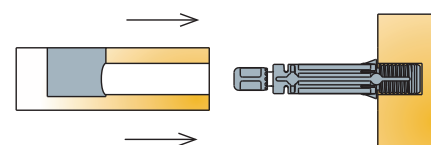

3. Assemble the panels

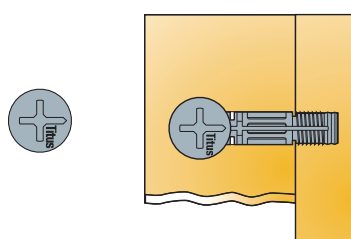

4. Tighten cam to lock dowel

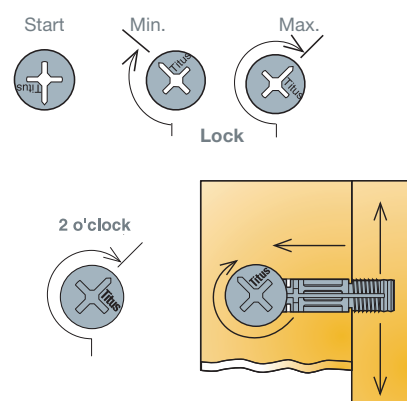

System 5 Cams and Dowels

Quickfit TL5 'Full Metal Jacket'

Effective performance in multiple wooden materials

- Smooth and noticeable locking at the 2 o'clock position guarantees:
- tight joints
 - always-right tightening at home assembly
 - strong and rigid cabinet construction



Strong and reliable joint

Expanding steel sleeve assures high resistance to torsion and pull-out.

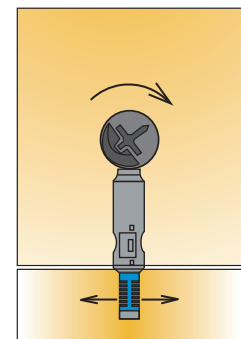

High drilling tolerances

An extended dowel head design works as a positive stop against the cam and provides an ETHC tolerance of min. +/-1mm

Fully tightened joint assured even at marginal inconsistencies of drilling and problems associated with the natural movement of wood panels.

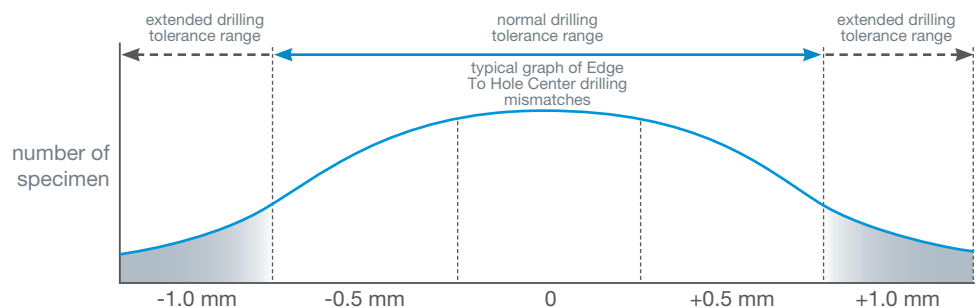
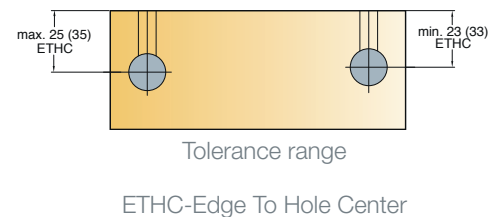

Shape of dowel sleeve

- Acts as a positive stop when face inserted
- Ensures correct insertion depth



Tool-free insertion for Ø5mm dowel holes

Quickfit TL5 reliably engages the 5mm dowel hole. It enables the usage of tool-less Quickfit dowel insertion technology across a wide range of applications.

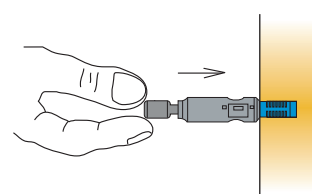

50% less time to assemble the cabinet at home

When edge inserted the dowel engages the cam and remains securely positioned until the boards are locked together.

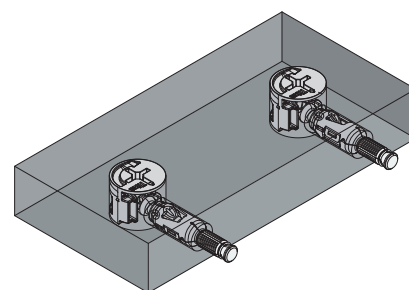

For maximum efficiency the insertion process can be automated using the Titus proprietary Lama FastFit machine.

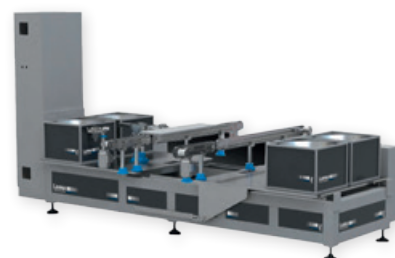

Fast and easy cabinet assembly at home.

CAF Quick & Easy

Consumer Assembly Friendliness

System 5 Cams and Dowels

Zinc+steel Combi Dowels

**Zinc+steel
technology for
optimal strength
and performance**

The Combi dowel combines steel and a small amount of zinc to ensure high precision and dimensional accuracy, essential to provide furniture manufacturers with the broadest possible range of drilling tolerances.

toroidal head form

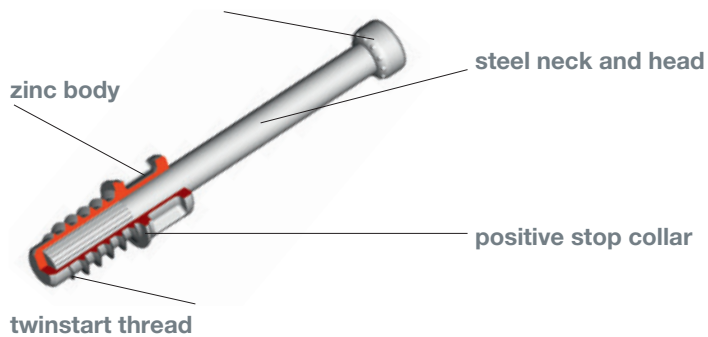

The steel neck and head provide better resistance to torsion and pull-out enabling a high performance joint

Zinc body:
Positive stop collar ensures correct insertion depth
Twinstart for faster and more stable insertion

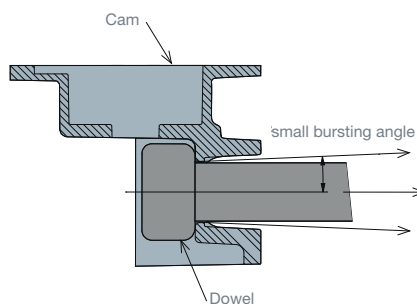

The toroidal dowel head form transfers the forces between cam and dowel more effectively resulting in a small cam bursting force.

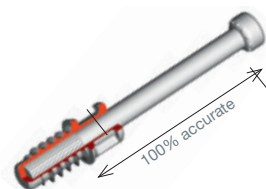

**100% dimensional accuracy
assured**

System 5 Cams and Dowels

Quickfit TL5 'Full Metal Jacket'

- Drilling tolerances of +1/-1mm when edge inserted
- Expanding steel sleeve assures a strong joint, highly resistant to pull-out
- Tool-free insertion technology for Ø5mm holes in multiple wooden materials (chipboard, MDF, solid wood)
- For use with Cam5000

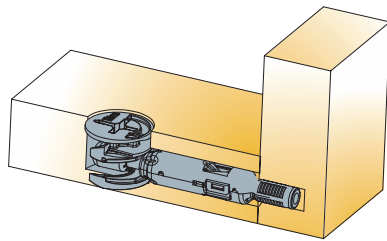

Technical and mounting details

Quickfit TL5 dowel

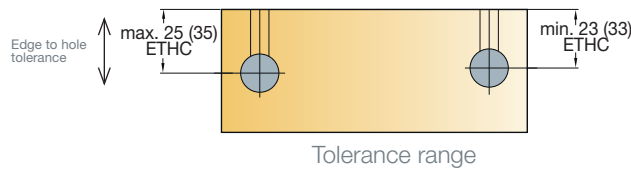
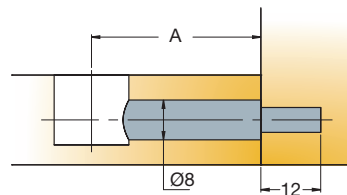
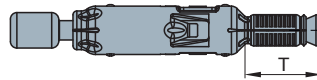

A	T	Item number	TeraBlack
Drilling distance	Thread length		
34	11.5	09652 →	956
24	11.5	09651 →	956

i Suitable for Cam5000 only

 1000 Pcs

Made of steel

System 5

Cams and Dowels

Quickfit TL Dowels

- Available in Ø5mm and Ø8mm for panel-to-panel applications
- For use with all Cam3000 S and Cam5000 products
- 'Klix' locking feature provides a strong, vibration proof joint
- Highly tolerant in edge-inserted, TL4 also in face-inserted applications

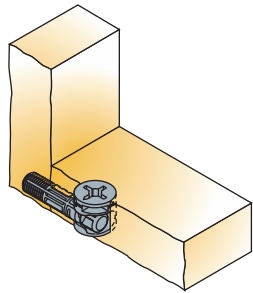

Technical and mounting details

Quickfit TL2

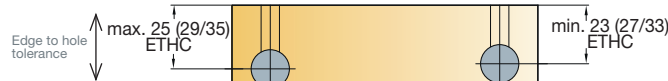
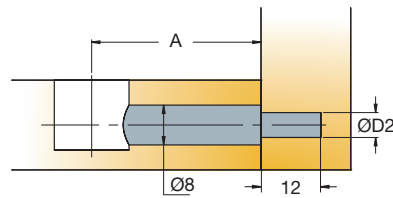
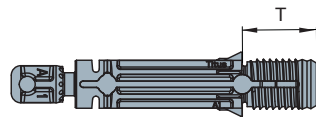

Tolerance range

2000 Pcs
1000 Pcs (05474)

Made of zinc, plastic

Quickfit TL4

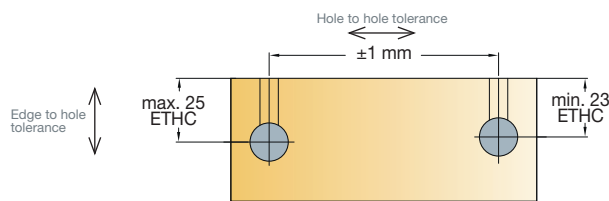
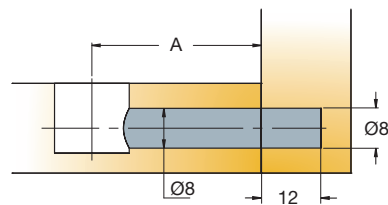
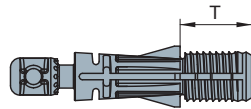

Tolerance range

3000 Pcs

Made of zinc, plastic

A	T	D2	Item number	Black	Dark grey
24	11.5	5	05453 →		880
34	11.5	5	05503 →		880
24	11.2	8	05366 →		880
28	11.2	8	05314 →		880
34	11.2	8	05474 →		880
24	11.2	8	05388 →	835	

System 5

Cams and Dowels

Quickfit Dowels

- Available in Ø5mm, Ø8mm and Ø10mm for panel-to-panel applications
- For use with all Cam3000 S and Cam5000 products
- 'Klix' locking feature provides a strong, vibration proof joint
- Depth stop collar for accurate insertion

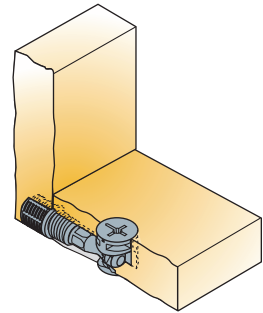

Technical and mounting details

Quickfit dowel
Ø8mm



1000 Pcs (05556,05552)
2000 Pcs (05563, 05554)

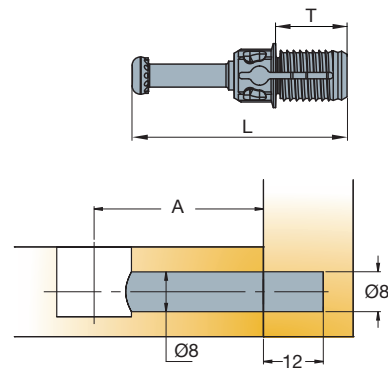

Made of zinc, plastic

Quickfit dowel
Ø10mm



2000 Pcs

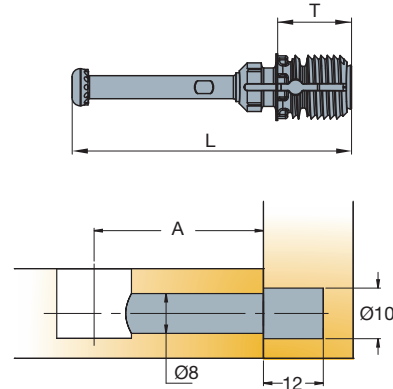

Made of zinc, plastic

Quickfit dowel
For back-to-back application
Ø10mm



1000 Pcs

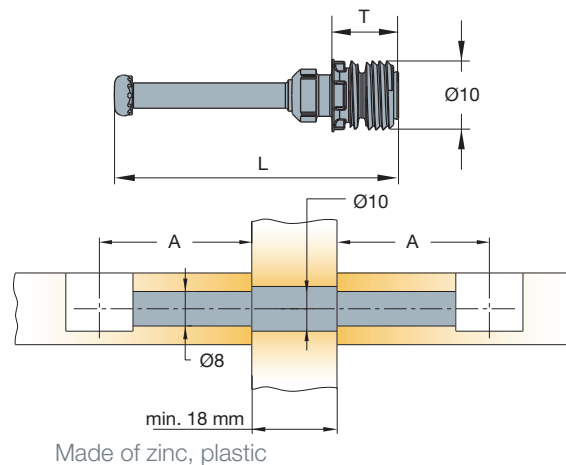

Made of zinc, plastic

A	T	L	Item number	Dark grey
Drilling distance	Thread length	Total length		
20	11.2	29.5	05556 →	880
24	11.2	33.5	05563 →	880
28	11.2	37.5	05552 →	880
34	11.2	43.5	05554 →	880
24	11.2	33	05052 →	880
34	11.2	43	05050 →	880
24	9	30.5	05270 →	880
34	9	40.5	05147 →	880

System 5

Cams and Dowels

Quickfit P2F Dowels

- The only product to enable standard panel drilling and connection of panel and hollow profile
- Available in Ø8mm for panel-to-hollow metal profile applications
- For use with all Cam3000 S and Cam5000 products
- 'Klix' locking feature provides a strong, vibration proof joint

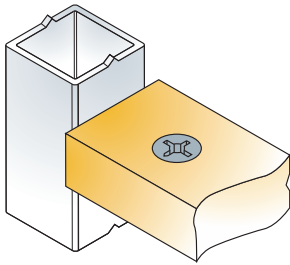

Technical and mounting details

Quickfit P2F

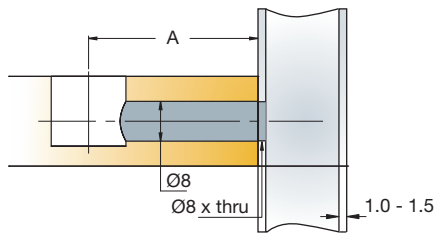
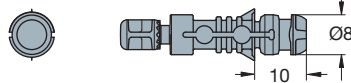

A

Drilling distance

Item number

Black

24

05414 →

835

2000 Pcs

Made of zinc, plastic

System 5

Cams and Dowels

Combi Dowel

- High quality zinc-steel dowel with greater resistance to torsion and pull-out
- For use with all Cam3000 S and Cam5000 products
- 'Klix' locking feature provides a strong, vibration proof joint
- Twinstart thread for faster and reliable insertion

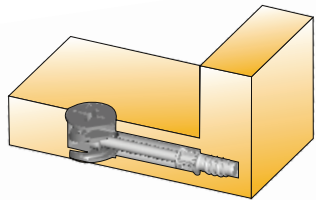

Technical and mounting details

Combi dowel

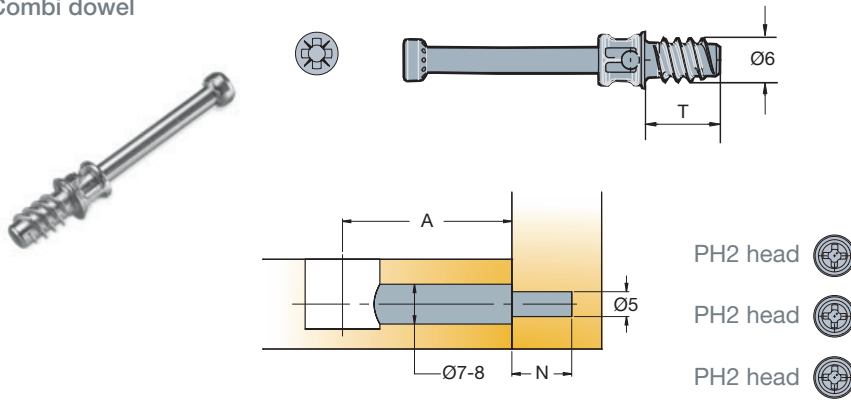

1000 Pcs
*2000 Pcs

Made of steel and zinc

Combi dowel M6

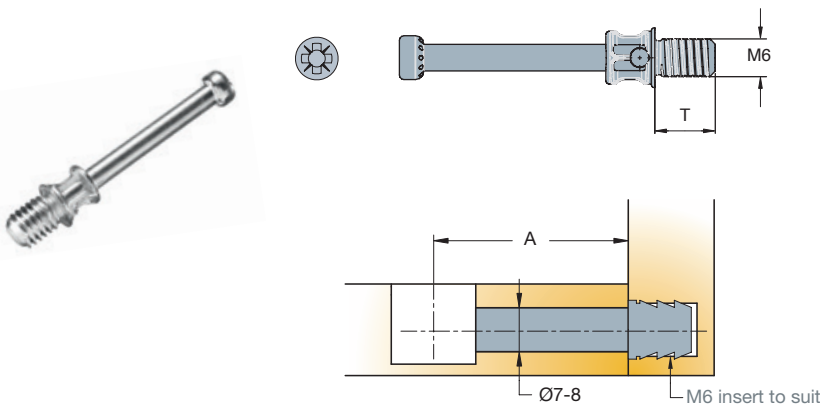

1000 Pcs

Made of steel and zinc



→ see page 1.70



Inserts
Made of plastic

→ see page 1.70

A	N	T	Item number	Zinc
Drilling distance	Drilling depth	Thread length		
34	12	11	09435 →	885
28	10	9.5	09588 →	885
24	12	11	09443 →	885
24	9	8.5	09583 →	885
34	12	11	*09424 →	885
24	12	11	*09423 →	885
34	9	8.5	*09456 →	885
<i>*American market only</i>				



34		8	09592 →	885
34		10.5	09594 →	885

System 5

Cams and Dowels

Combi Dowel

- High quality zinc-steel dowel with greater resistance to torsion and pull-out
- For use with all Cam3000 S and Cam5000 products
- 'Klix' locking feature provides a strong, vibration proof joint
- Twinstart thread for faster and reliable insertion

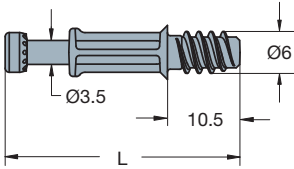
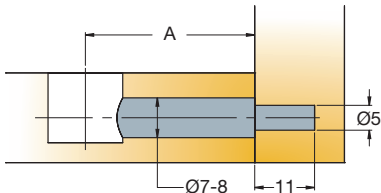
		L	A		
Technical and mounting details		Total length	Drilling distance	Item number	Zinc
Combi dowel Full body	PZ2 head 	34.5	24	09597 →	885
  					

 1000 Pcs

Made of steel and zinc

 Inserts
Made of plastic





→ see page 1.70

System 5

Cams and Dowels

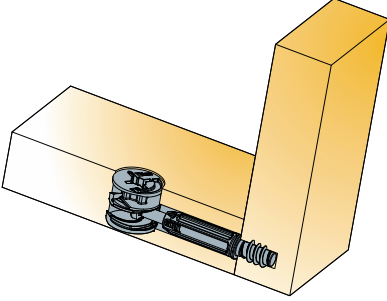
Combi-P Dowel

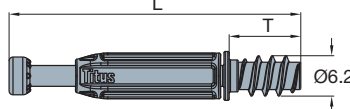
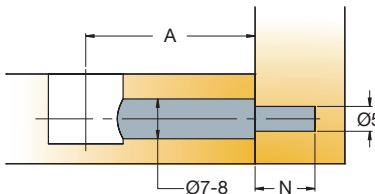
- Full body assures a strong joint highly resistant to torsion and pull-out, even in low density chipboard
- Accurate insertion with positive stop

		A	N	T	L		
Technical and mounting details		Drilling distance	Drilling depth	Thread length	Total Length	Item number	Zinc plated
<p>Combi-P Dowel</p>    	PH2 head 	34	12	11	44.8	05072 →	883
		24	12	11	34.8	05073 →	883
		24	9	8.5	32.3	05087 →	883
	PZ2 head 	34	12	11	44.8	05078 →	883
		24	12	11	34.8	05079 →	883

 1000 Pcs

Made of zinc and plastic

System 5

Cams and Dowels

Double-ended Dowel

- Available in Ø7mm
- For use with all Cam3000 S and Cam5000
- No circlip for increased tolerance
- Available in a variety of lengths to suit most panel-to-panel applications

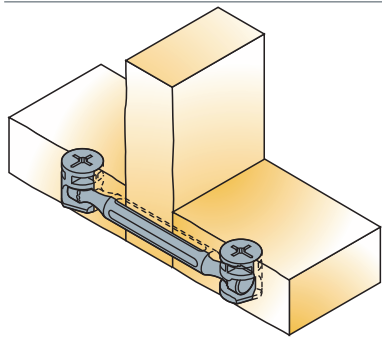

Technical and mounting details

Dowel without circlip

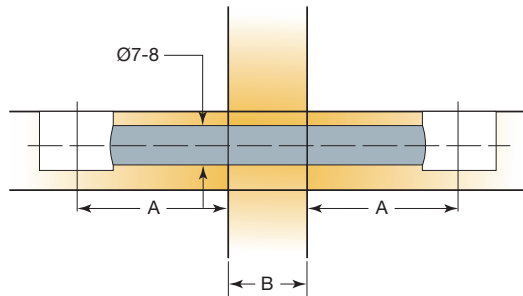
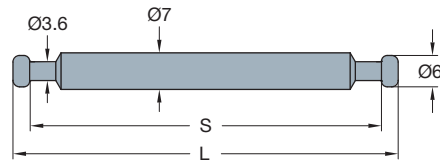

- 250 Pcs (05753)
- 500 Pcs (05857)
- 1000 Pcs (05929)

Made of steel

Dowel with circlip

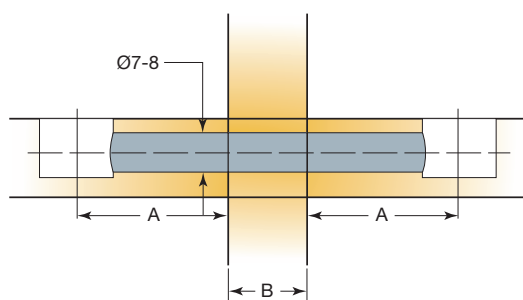
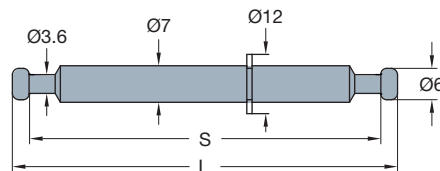

- 250 Pcs
- 500 Pcs (05775, 05774)

Made of steel

S	L	A	B	Item number	Zinc plated
Length	Total length	Drilling distance	Panel thickness		
41	47.4	24	0*	05929 →	883
61	67.4	34	0*	05757 →	883
77	83.4	34	16	05858 →	883
79	85.4	34	18	05859 →	883
80	86.4	34	19	05753 →	883
56	62.4	24	15	05592 →	883
57	63.4	24	16	05857 →	883
59	65.4	24	18	05380 →	883
60	66.4	24	19	05778 →	883
*B=0 → no panel required					
77	83.4	34	16	05752 →	883
79	85.4	34	18	05772 →	883
80	86.4	34	19	05751 →	883
57	63.4	24	16	05775 →	883
60	66.4	24	19	05774 →	883

System 5

Cams and Dowels

Angled Dowels

- For applications requiring angled joints
- For use with all Cam3000 S and Cam5000
- Adjustable angle from 90° to 180°

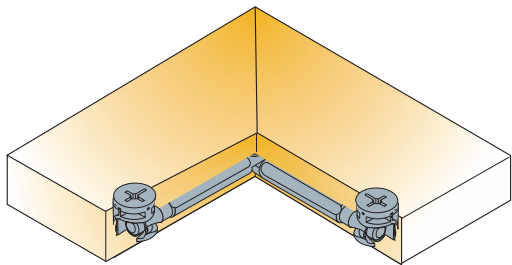

Technical and mounting details

Item number

Zinc plated

Cabinet Connectors

Angled dowel
180° fixed

05860 →

883

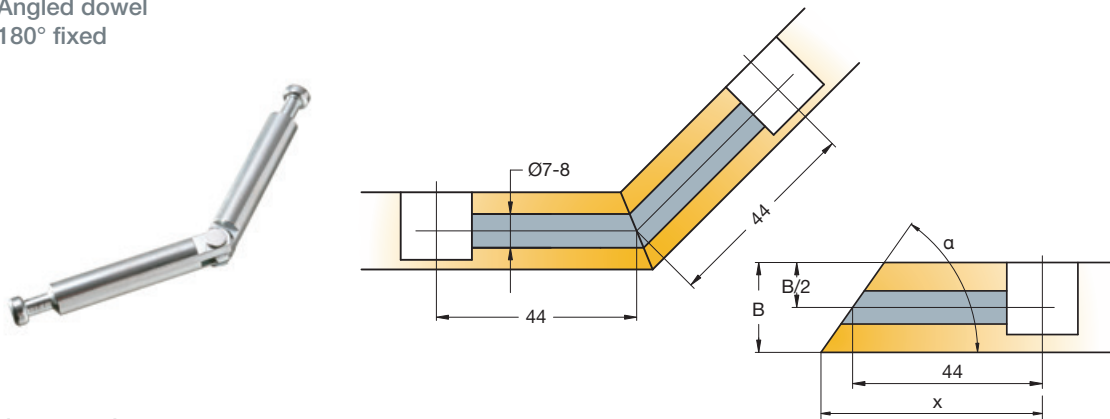

Distance x in mm

Q	20°	25°	30°	35°	40°	45°	50°	55°	60°	65°	67,5°	70°	75°	80°	85°		
13	61.9	57.9	55.3	53.5	51.7	50.5	49.5	48.6	47.8	47	46.7	46.4	45.7	45.1	44.6		
15	64.6	60.1	57	54.7	52.9	51.5	50.3	49.3	48.3	47.5	47.1	46.7	46	45.3	44.7		
16	66	61.2	57.9	55.4	53.5	52	50.7	49.6	48.6	47.7	47.3	46.9	46.1	45.4	44.7		
B	18	68.8	63.3	59.6	56.9	54.7	53	51.6	50.3	49.2	48.2	47.7	47.3	46.4	45.6	44.8	
	19	70.1	64.4	60.5	57.6	55.3	53.5	52	50.7	49.5	48.4	47.9	47.5	46.5	45.7	44.8	
	22	74.2	67.6	63.1	59.7	57.1	55	53.2	51.7	50.4	49.1	48.6	48	46.9	45.9	45	
	23	75.6	68.7	63.9	60.4	57.7	55.5	53.6	52.1	50.6	49.4	48.8	48.2	47.1	46	45	x

250 Pcs

Made of steel

Angled dowel
90° fixed

05282 →

883

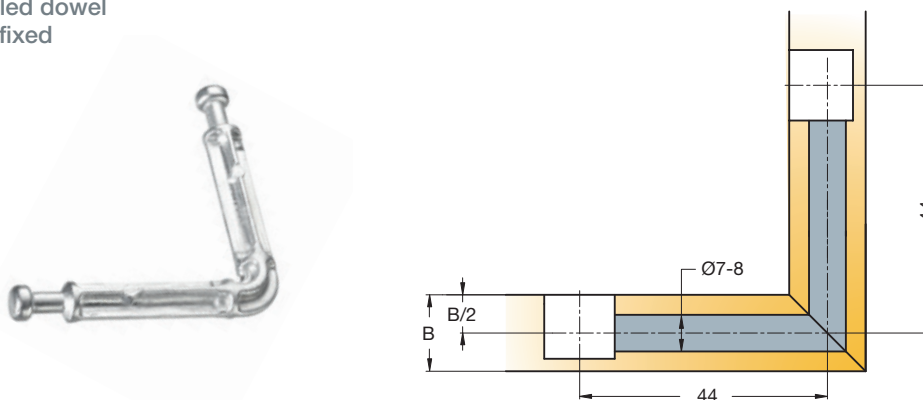

1000 Pcs



Made of steel



System 5

Cams and Dowels

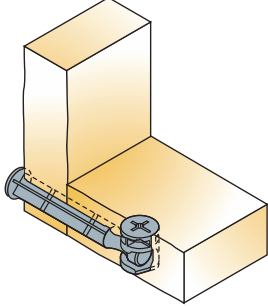
End Dowels

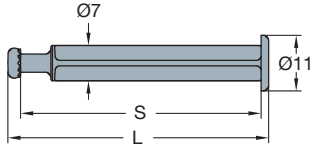
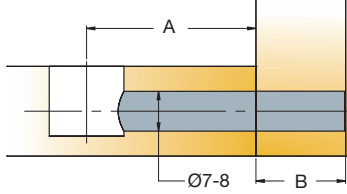
- Available in a variety of head and length combinations to suit most end panel applications
- For use with all Cam3000 S and Cam5000
- 'Klix' locking feature provides a strong, vibration proof joint
- Both 'mushroom' and countersunk headed versions available

 Technical and mounting details		A	B	S	L	Item number	Zinc
		Drilling distance	Panel thickness	Length	Total length		
Mushroom dowel 							
	24	16	36.5	40.5	05608 →	885	
	24	19	39.5	43.5	05609 →	885	
	34	16	46.5	50.5	05610 →	885	
	34	19	49.5	53.5	05611 →	885	
24	12	32.6	37.3	05010 →	885		
							

 500 Pcs (05610, 05611)
 1000 Pcs (05608, 05609)

Made of zinc

System 5

Cams and Dowels

Cam5000 Ø15mm

- Improved central shape for highly resistant joint
- For use with all Titus dowels
- 'Klix' locking feature provides a strong, vibration proof joint
- Cam retaining pips ensure that a cam is held in panel position prior to assembly

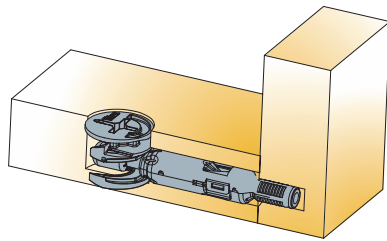

Technical and mounting details

B	D	e	h	Item number	Zinc	Noir
Panel thickness	Drilling depth	Drilling for dowel	Cam height			
12/13	10.5	6 min	9.9	09695 →	885	959
15/16	12.5	7.5-8	11.9	09690 →	885	959
<i>Noir available upon request</i>						
15/16	12.5	7.5-8	11.9	09699 →	885	
18/19	14	9-9.5	13.2	09692 →	885	959
22/23	16	11-11.5	15.2	09332 →	885	
25/26	18	12.5-13	16.7	09335 →	885	
28/29	19.5	14-14.5	18.2	09336 →	885	959

Cam5000 cross drive

PZ2 drive 

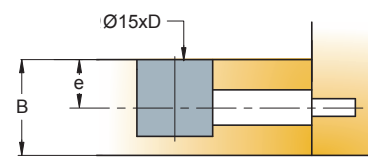
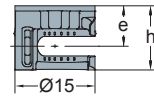



 1000 Pcs

Made of zinc

Cam5000 hexagonal drive

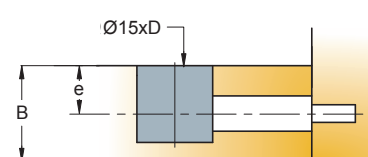
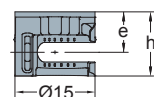
Combined drive with HEX 



 1000 Pcs
500 Pcs (9335, 9336)

Made of zinc

 Cover caps for Ø15 cams → see page 1.44
Made of plastic

System 5

Cams and Dowels

Cam5000 Ø15mm

- Improved central shape for highly resistant joint
- For use with all Titus dowels
- 'Klix' locking feature provides a strong, vibration proof joint
- Cam retaining pips ensure that a cam is held in panel position prior to assembly

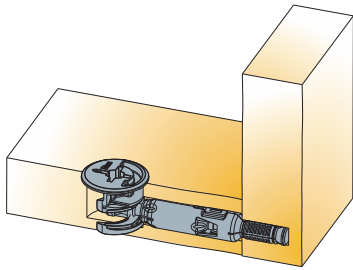

Technical and mounting details

Cam5000 headed cross drive

PZ2 drive 

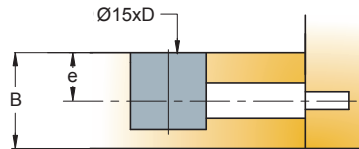
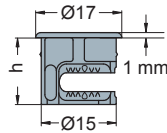



 1000 Pcs

Made of zinc

Cam5000 headed hexagonal drive

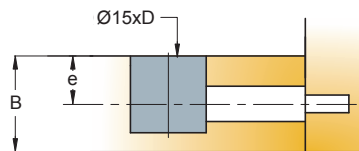
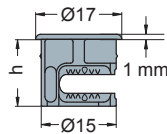
Combined drive with HEX 



 1000 Pcs
500 Pcs (9337)

Made of zinc

B	D	e	h	Item number	Nickel	Zinc	Noir
Panel thickness	Drilling depth	Drilling for dowel	Cam height				
12	10min	6	9.9	09330 →		885	
<i>Noir available upon request</i>							

16	13	8	12.4	09333 →	847	885	
19	14.5	9.5	13.9	09334 →	847	885	
29	19.5	14.5	18.9	09337 →		885	













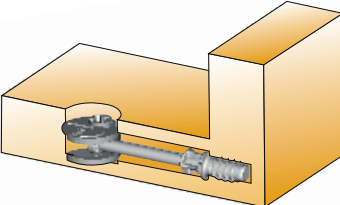

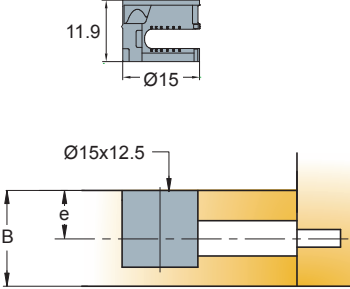
<i>Noir available upon request</i>							
------------------------------------	--	--	--	--	--	--	--

System 5

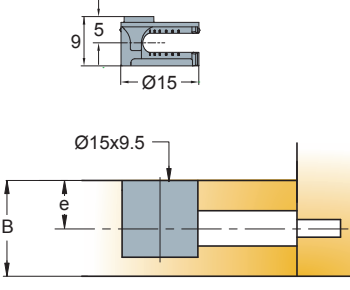
Cams and Dowels

Cam3000S Ø15mm

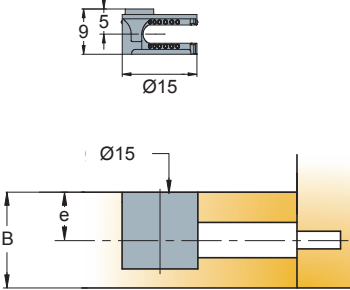
- Innovative design offers optimal performance with maximum cost effectiveness
- For use with Combi dowels, forged steel dowels and Quickfit dowels
- 'Klix' locking feature provides a strong, vibration proof joint
- Cam-retaining pins ensure that a cam is held in panel position prior to assembly

Technical and mounting details		B	e	Item number	Zinc	Zinc corrosil
		Panel thickness	Drilling for dowel			
 <p>Cam3000 S/15</p> <p>PZ2 drive </p>	 <p>11.9 Ø15</p> <p>Ø15x12.5</p> <p>B e</p>	15/16	7.5/8	09491 →	885	897
 <p>1000 Pcs</p> <p>Made of zinc</p>						
 <p>Cam3000 S/12</p> <p>PZ2 drive </p>	 <p>9 5 Ø15</p> <p>Ø15x9.5</p> <p>B e</p>	12 min	min 6	*09406 →	885	897
 <p>2000 Pcs</p> <p>Made of zinc</p>				<i>* European market only</i>		
 <p>Cam3000 S/12</p> <p>Philips PH2 drive </p>	 <p>9 5 Ø15</p> <p>Ø15</p> <p>B e</p>	12 min	min 6	*09631 →	885	
 <p>1000 Pcs</p> <p>Made of zinc</p>				<i>* American market only</i>		

 Cover caps 09630
Made of plastic

System 5

Cams and Dowels

Cam2000S Ø12mm

- For all Titus screw-in dowels
- Available in a variety of head, drive recess and board thickness versions to suit most applications
- Particularly suited to drawer front attachment applications
- 'Klix' locking feature provides a strong, vibration proof joint

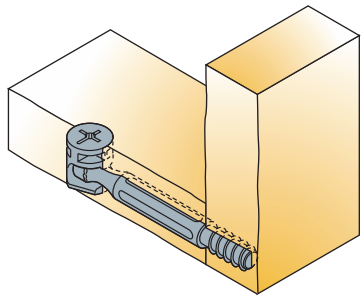

Technical and mounting details

Cam2000
Ø12mm

PZ2 drive 

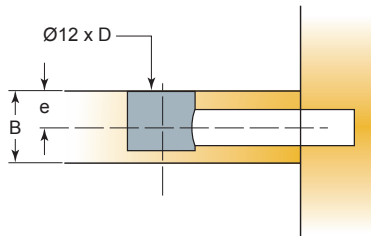
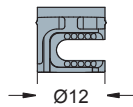



 2000 Pcs

Made of zinc

Cam2000
Ø12mm headed

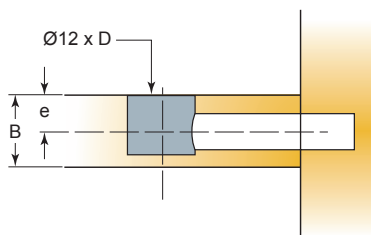
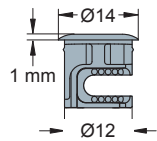
PZ2 drive 



 1000 Pcs
2000 Pcs (05576)

Made of zinc

B	D	e	Item number	Black painting plate	Nickel plated	Zinc	Corrosil zinc
12/13	10 min	6-6.5	05575 →	838	847	885	897
15/16	12	7.5-8	05578 →			885	
18/19	13 min	9-9.5	05580 →			885	

Other finishes on request

i Not suitable for Quickfit TL5 dowels







12	9.2 min	5.25	05574 →	838	847	885	897
12	10 min	6	05576 →			885	
16	12.5	8	05579 →			885	

Other finishes on request

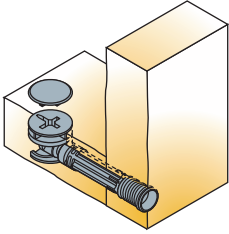
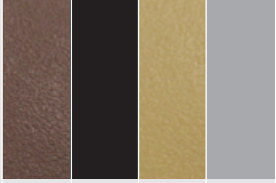
i Not suitable for Quickfit dowels

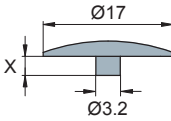
System 5 Cover Caps

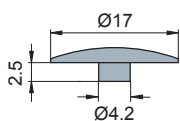
- Available in a variety of colours
- For use with both pozi and hex cam drive features
- Suitable for use with various diameter cams
- Both domed and flat versions available

 Technical and mounting details		X					
			Pin length	Item number	Dark brown	Black	Light brown
Cover cap Ø17mm 		3.3	*01029 →	834	835	867	882
		2.5	277-4355 →	370	390	330	380
 1000 Pcs Made of plastic		*American market only Other colours on request Suitable for cams with Pozi 2 recess					
Cover cap Ø17mm 			277-4225 →	370	390	330	380
		Other colours on request Suitable for cams with Hex recess					
 1000 Pcs Made of plastic							

System 6

Quickfit-Expando

Connectors

System Features

A face boring connector family for 32mm system drilling with full range of panel and application variants for all cabinet manufacturing applications.

- Minimum drilling requirements
- Linear cam design for constant tightening loads when driving
- Angledriv feature on cam for maximum driving comfort
- Interchangeable pins for wood, plastic and steel applications
- Pins with twinstart drive for fast insertion
- Interchangeable Quickfit pin fastenings available
- Tool-less fastening capable versions
- Back-to-back fastenings for common vertical panel fixing of shelves

System 6 consists of a range of 20mm diameter housing, Quickfit™ and conventional dowels, end dowels and double ended dowels.

Housings are made from high grade plastic or zinc, with zinc cams.

Wedgefix-6 connector is a special fastener without cam, simply to snap onto a pre-inserted dowel.

Applications

Titus System 6 is ideal for use in high volume production of case goods, closet and garage storage systems. Because no

edge boring is required, it is an excellent choice for manufacturing environments with limited drilling capacity.

Side-entry Drop-on

Side-entry insertion of shelf panel: from the side or from the top

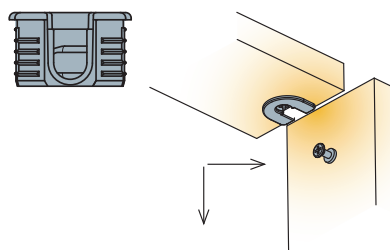

Drop-on insertion of shelf panel: only from the top
Using drop-on connections allows for one-man installation

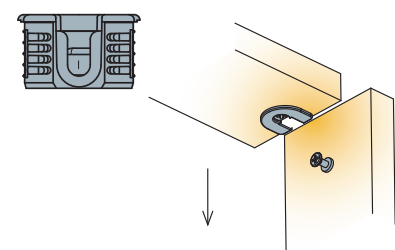

**Outrigger/
Non outrigger**

Outrigger

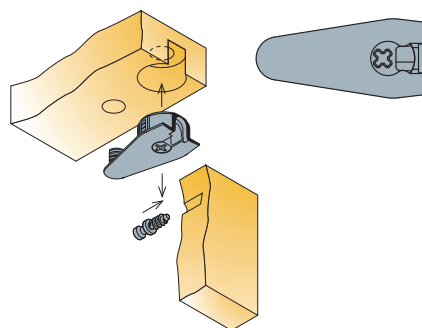

Non outrigger

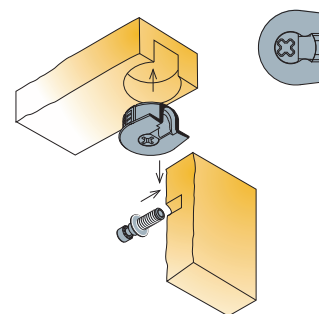

Expando function

Expanding housings and dowels provide a tight joint.

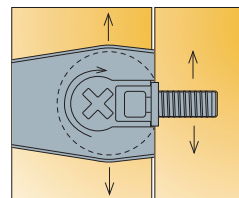
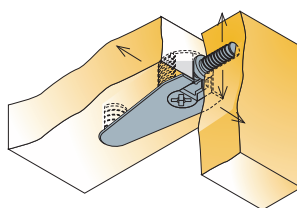

Assembly

1. Press the housing into face board

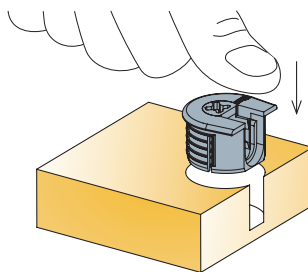

2. Press the dowel into side panel

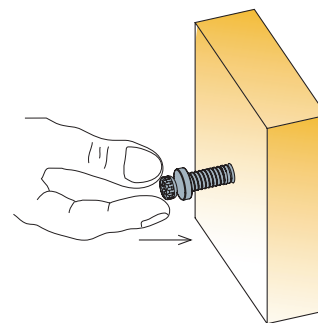

3. Assemble the panels

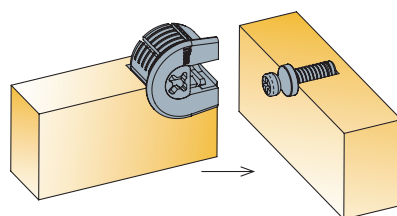



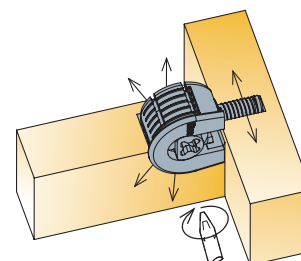

4. Tighten the joint

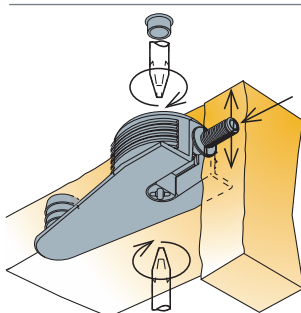

System 6 Quickfit-Expando Expanding Dowels

i Not suitable for System 6.2

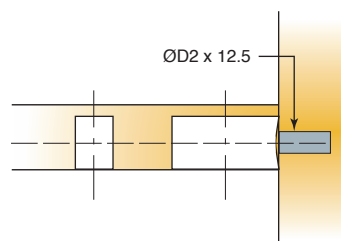
- Available in Ø5mm, Ø8mm for panel-to-panel, and back-to-back applications
- For applications with all Titus Ø20 and Sys 6 housings
- 'Klix' locking feature provides a strong, vibration proof connection
- Depth stop collar for accurate insertion

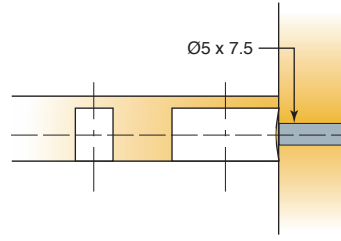
 <p>Technical and mounting details</p>	D2	Drilling diameter for dowel thread	Item number	Dark grey
<p>Dowel</p>  <p>D2= Ø5mm</p>  <p>D2= Ø8mm</p>  <p>Ø2 x 12.5</p> <p>5000 Pcs</p> <p>Made of zinc, plastic</p>	5	06408 →	880	
	8	06410 →	880	
<p>Dowel Ø5 x 7.5 back-to-back applications</p>   <p>Ø5 x 7.5</p> <p>5000 Pcs</p> <p>Made of zinc, plastic</p>	5	06479 →	880	

System 6 Quickfit-Expando Dowels

- Available in various Ø3mm and/or Ø5mm thread forms for screw-in, knock-in and/or 'spiked' hole applications
- For applications with all Titus Ø20mm and Sys 6 housings
- 'Klix' locking feature provides a strong, vibration proof connection
- Dowels feature an integral skirt which acts as a positive stop during insertion

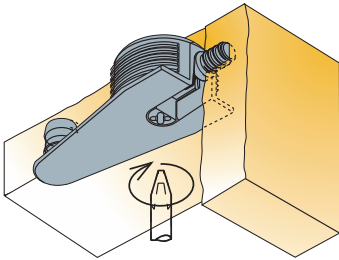

Technical and mounting details

C	Drilling depth for dowel thread	Item number	Material	
			Zamak	Zinc plated
	9	06401 →	885	
	8	06402 →	885	883
	11.5	06406 →	885	883
		06403 →	885	
		06405 →		883
		06495 →		883

Dowel Ø5

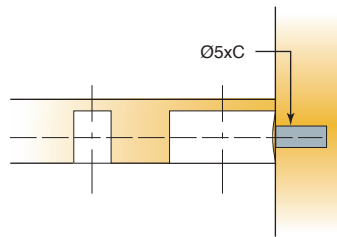

2000 Pcs

Made of zinc or steel

Dowel Ø5 x 11 knock-in

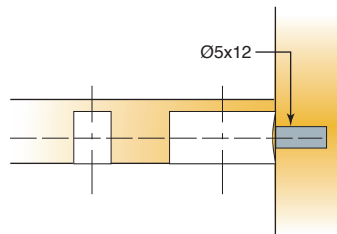

2000 Pcs

Made of zinc

Dowel M4 x 7

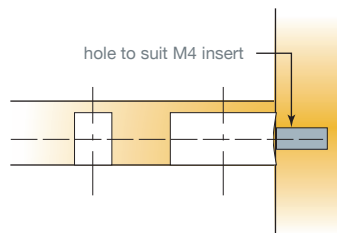

4500 Pcs

Made of steel

Dowel Ø3 x 11.5

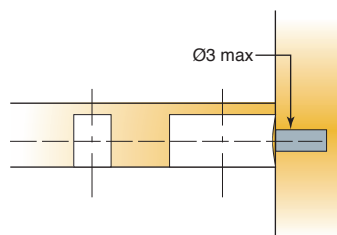

12500 Pcs

Made of steel

Inserts
Made of plastic

→ see page 1.70

System 6

Quickfit-Expando

Double-ended Dowels

- For 16mm, 18mm and 19mm board
- For applications with all Titus Ø20mm and Sys 6 housings
- 'Klix' locking feature provides a strong, vibration proof connection

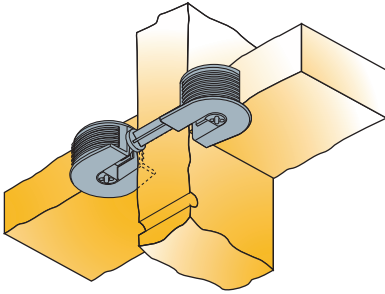

Technical and mounting details

Double-ended dowel

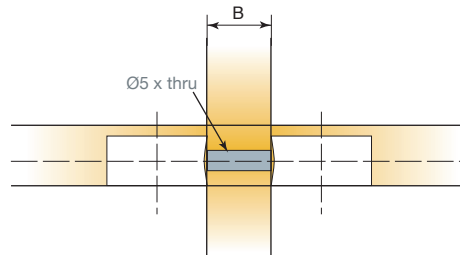
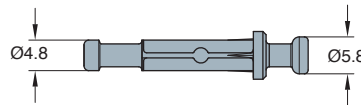

B	Item number	Zinc
Panel thickness		
16	06414 →	885
18	06413 →	885
19	06416 →	885

2500 Pcs

Made of zinc

System 6 Quickfit-Expando End Dowels

- For 16mm, 18mm and 19mm board
- For applications with all Titus Ø20mm and Sys 6 housings
- 'Klix' locking feature provides a strong, vibration proof connection

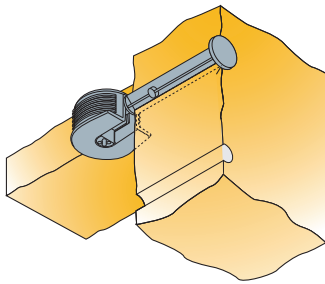

Technical and mounting details

End dowel

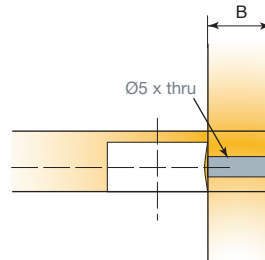
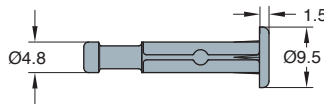

B	Item number	Zinc
Panel thickness		
16	06412 →	885
18	06411 →	885
19	06415 →	885

2000 Pcs
1000 Pcs (06411)

Made of zinc







System 6

Quickfit-Expando

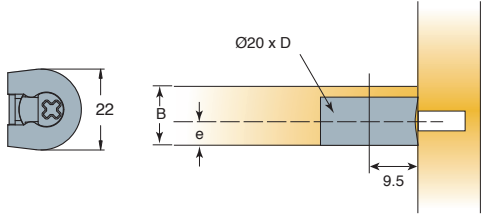
20mm Expanding Housing

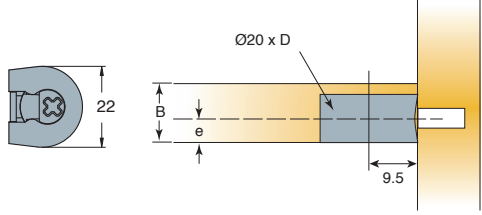
Non-outrigger

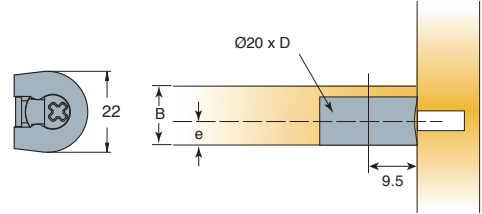
- Available in 15mm/16mm and 18mm/19mm versions for drop-on and/or side-entry applications
- Available in all-metal or plastic/metal options
- 'Klix' locking feature provides a strong vibration proof connection
- Compatible with all Sys 6 screw-in and Quickfit dowels

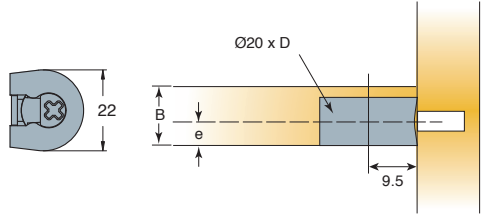
Technical and mounting details				e	B	D	Item number	Dark brown plastic	Nickel plated	Silver plastic	White plastic
					Panel thickness	Drilling depth					
Side-entry  500 Pcs Made of zinc		7.75	15/16	12.5	06451 →		847				
		9.25	18/19	14	06453 →		847				
Side-entry  2500 Pcs Made of plastic		7.75	15/16	12.5	06435 →	831		861	877		
		9.25	18/19	14	06437 →	831		861	877		
<i>Other colours on request</i>											
Drop-on  500 Pcs Made of zinc		7.75	15/16	12.5	06447 →		847				
		9.25	18/19	14	06449 →		847				
Drop-on  2500 Pcs Made of plastic		7.75	15/16	12.5	06431 →	831		861	877		
		9.25	18/19	14	06433 →	831		861	877		
<i>Other colours on request</i>											

System 6

Quickfit-Expando

20mm Expanding Housing

Outrigger

- Available in 15mm/16mm and 18mm/19mm versions for drop-on and/or side-entry applications
- Available in all-metal or plastic/metal options
- 'Klix' locking feature provides a strong vibration proof connection
- Compatible with all Sys 6 screw-in and Quickfit dowels

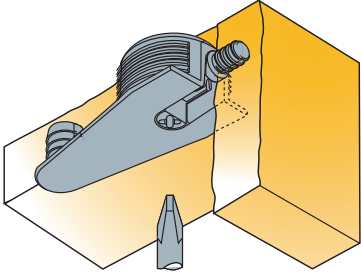
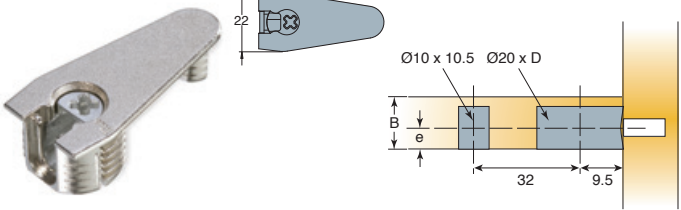
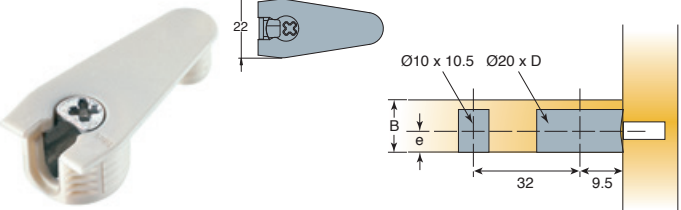
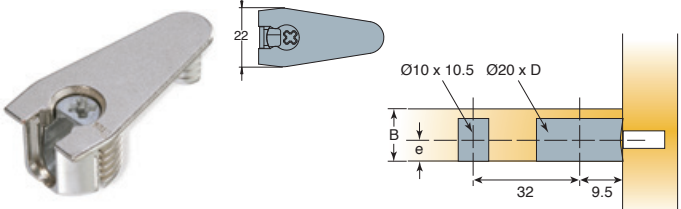
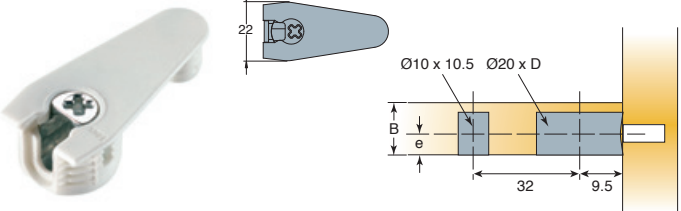
Technical and mounting details		e	B	D	Item number	Dark brown plastic	Black plastic	Nickel plated	White plastic
 <p>Technical and mounting details</p>			Panel thickness	Drilling depth					
Side-entry	 <p>500 Pcs Made of zinc</p>	7.75	15/16	12.5	06459 →			847	
		9.25	18/19	14	06461 →			847	
Side-entry	 <p>1250 Pcs Made of plastic</p>	7.75	15/16	12.5	06443 →				877
		9.25	18/19	14	06445 →	831	835		877
		9.25	18/19	14	*06395 →		835		877
		Other colours on request *American market only							
Drop-on	 <p>500 Pcs Made of zinc</p>	7.75	15/16	12.5	06455 →				847
		9.25	18/19	14	06457 →				847
Drop-on	 <p>1250 Pcs Made of plastic</p>	7.75	15/16	12.5	06439 →		835		877
		9.25	18/19	14	06441 →	831	835		877
		9.25	18/19	14	*06397 →		835		877
		Other colours on request *American market only							

System 6

Quickfit-Expando

Expanding Wedgefix Housing (no Inner Cam)

- Available in 12mm, 15mm/16mm and/or 18mm/19mm versions for Sys 6 screw-in and Quickfit dowel applications
- Available in a variety of plastic colours
- Wedgefix housing allows easy customer hand-assembly or factory automated insertion
- When used with Sys 6 Quickfit dowels this provides a true tool-less fastening system

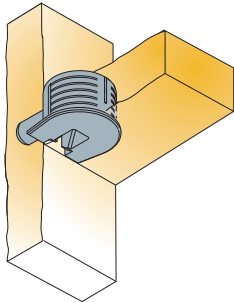

Technical and mounting details

For use with screw-in dowels

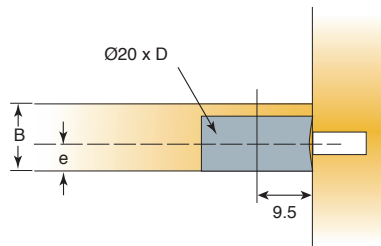
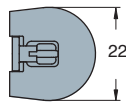

2500 Pcs

Made of plastic

For use with Quickfit dowels

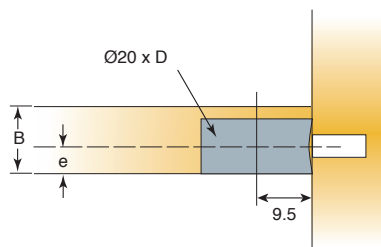
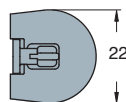

2500 Pcs

Made of plastic

e	B	D	Item number	White	Black	Dark brown	Silver
6	12	10	06470 →	877			861
7.75	15/16	12.5	06473 →	877	835	831	861
9.25	18/19	14	06465 →	877	835	831	861
11	22	16	06464 →				861
<i>Other colours on request</i>							
7.75	15/16	12.5	06471 →	877	835	831	861
9.25	18/19	14	06472 →	877	835	831	861
<i>Other colours on request</i>							

System 6

20mm Knock-in Housing

Non-outrigger

- Available in 15mm/16mm and 18mm/19mm versions for drop-on and/or side-entry applications
- Available in plastic-metal options
- 'Klix' locking feature provides a strong vibration proof connection
- Compatible with all Sys 6 screw-in and Quickfit dowels

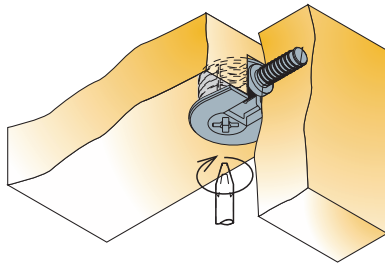

Technical and mounting details

Side-entry

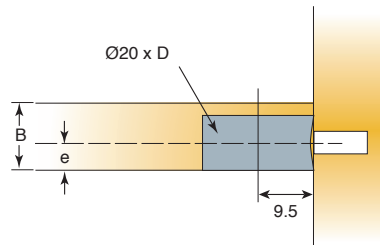
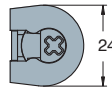

2500 Pcs

Made of plastic

Drop-on

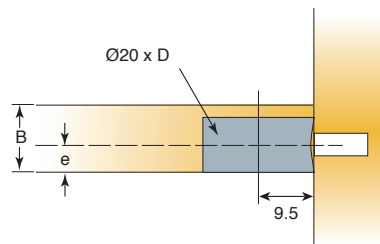
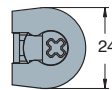

2500 Pcs

Made of plastic

Cover cap 06936
Made of steel

e	B	D	Item number	Silver plastic	White plastic
7.75	15/16	12.5	06381 →	861	877
9.25	18/19	14	06385 →	861	877
<i>Product available on American and Asian market only</i>					
<i>Other colours on request</i>					

7.75	15/16	12.5	06383 →	861	877
9.25	18/19	14	06387 →	861	877
<i>Product available on American and Asian market only</i>					
<i>Other colours on request</i>					

System 6

Flush 20mm Knock-in Housing Non-outrigger

i For use with dedicated drill bit only.
See below.

- A face-boring connector with the flush housing permits easy flat-pack transportation without panel damage
- Available for 19mm board thickness for drop-on and/or side-entry applications
- 'Klix' locking feature provides a strong vibration proof connection
- Compatible with all Sys6 screw-in and Quickfit dowels

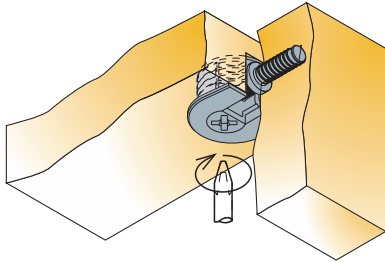

Technical and mounting details

e	B	D	Item number	White plastic
	Panel thickness	Drilling depth		

Side-entry

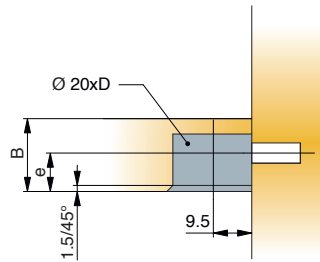
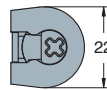

9.5	19	14.2	*06343 →	877
-----	----	------	----------	-----

*American market only

1000 Pcs

Housing made of plastic, cam made of zinc

Drop-on

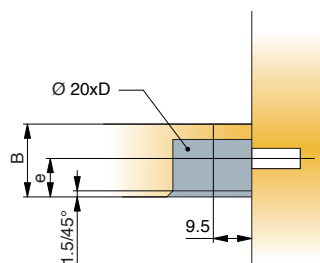
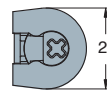

9.5	19	14.2	*06348 →	877
-----	----	------	----------	-----

*American market only

1000 Pcs

Housing made of plastic, cam made of zinc

Drill bit for Flush 20mm Knock-in housing

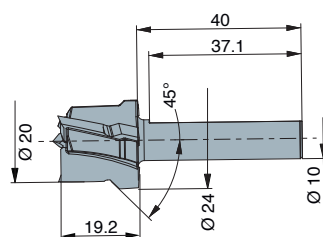

right handed

left handed

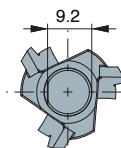

			00435	
			00436	

*American market only

1 Pcs

Made of carbon steel

System 6.2

Quickfit-Expando

Connectors

System Features

A face boring connector family for 32mm system drilling with full range of panel and application variants for all cabinet manufacturing applications.

- Minimum drilling requirements
- Anti-rotation ribs prevent rotation during tightening for reliable product performance
- Angledriv feature on cam for maximum driving comfort
- Interchangeable pins for wood, plastic and steel applications
- Pins with twinstart drive for fast insertion
- Interchangeable Quickfit pin fastenings available
- Tool-less fastening capable versions
- Back-to-back fastenings for common vertical panel fixing of shelves

System 6.2 consists of a range of 20mm diameter housing, Quickfit™ and conventional dowels, end dowels and double ended dowels.

Housings are made from high grade plastic with zinc cams.

Wedgex connector is a shelf fastener without cam, simply to snap onto a pre-inserted dowel.

Applications

Titus System 6.2 is ideal for use in high volume modular cabinet production: closets, wardrobes, garage storage systems, and shelving units.

Because no edge boring is required, it is an excellent choice for manufacturing environments with limited drilling capacity.

Side-entry Drop-on

Side-entry insertion of shelf panel: from the side or from the top

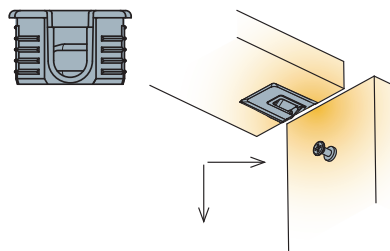

Drop-on insertion of shelf panel: only from the top
Using drop-on connections allows for one-man installation

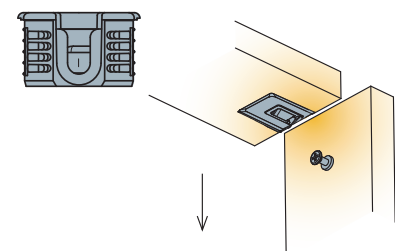

Efficient square design

Square shape guides the eye to easy insertion parallel to the board panel and allows a larger surface of the product

to rest on the panel when tightened for optimal positioning and ease at tightening.

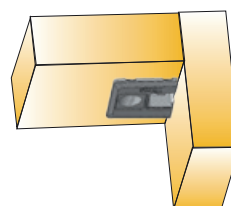

Ribs on housing prevent rotation in panel

The anti-rotation ribs on the housing prevent cam rotation and the resultant panel shift.

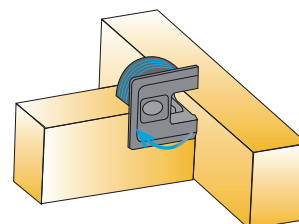

Comfortable tightening with Angledriv

The Angledriv feature on the cam guides the screwdriver to a 27° angle for comfortable access. The locking action creates a tight, secure fit.

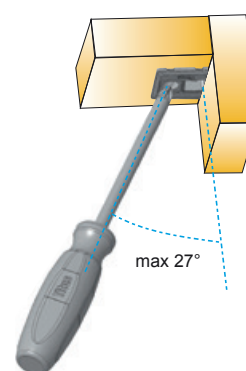

Easy and quick assembly with Quickfit dowel

Improved 'at-home' assembly experience.

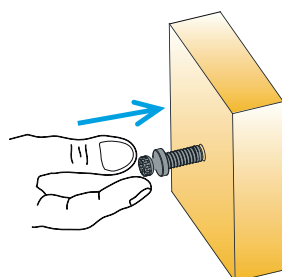

System 6.2

Quickfit Dowels

i Suitable for System 6.2 only

- Tool-free insertion
- Depth stop collar assures accurate insertion
- Available in Ø5mm and Ø8mm
- For applications with all Titus Sys 6.2 Ø20mm housings

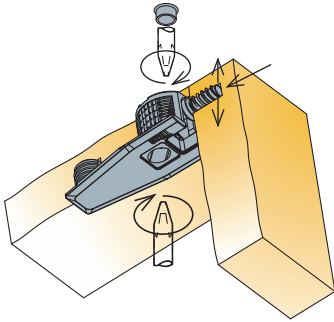

Technical and mounting details

Item number

Dark grey

Quickfit dowel Ø5mm

06576 →

880

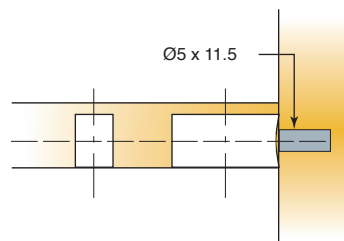

 5000 Pcs

Made of zinc, plastic

Quickfit dowel Ø5mm for back-to-back application

06627 →

880

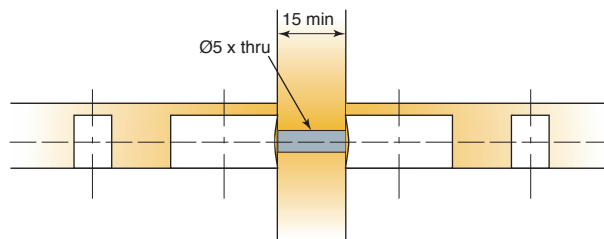

 5000 Pcs

Made of zinc, plastic

Quickfit dowel Ø8mm

06629 →

880

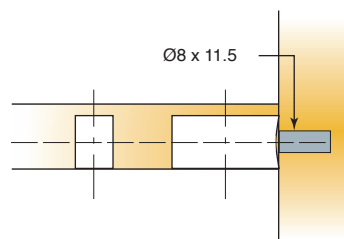











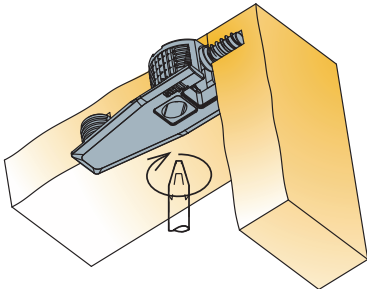



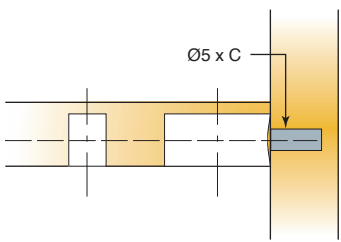

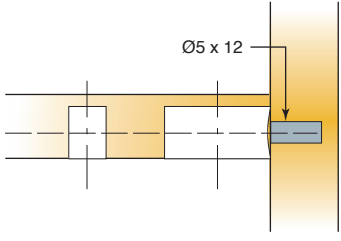

 5000 Pcs

Made of zinc, plastic

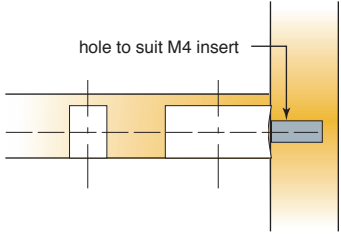
System 6.2

Screw-in Dowels

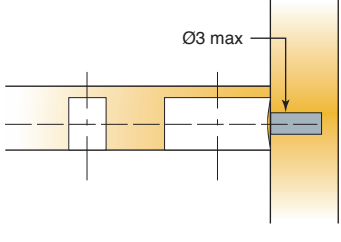
- Available in Ø3mm and Ø5mm thread forms for screw-in, knock-in and 'spiked' hole applications
- For applications with all Titus Sys 6.2 Ø20mm housings
- Dowels feature an integral skirt which acts as a positive stop during insertion

 Technical and mounting details		C	Drilling depth for dowel thread	Item number		
					Zinc plated	Zamak
Dowel Ø5     2000 Pcs Made of zinc or steel	9	06401 →		885		
	8	06402 →	883	885		
	11.5	06406 →	883	885		
Dowel Ø5 x 11 knock-in     2000 Pcs Made of zinc		06403 →		885		
Dowel M4 x 7     4500 Pcs Made of steel		06405 →	883			
Dowel Ø3 x 11.5     12500 Pcs Made of steel		06495 →	883			

 Inserts
 Made of plastic
 → see page 1.70

System 6.2

Double-ended Dowels

- For 16mm, 18mm and 19mm board
- For applications with all Titus Sys 6.2 Ø20mm housings
- 'Klix' locking feature provides a strong, vibration proof connection

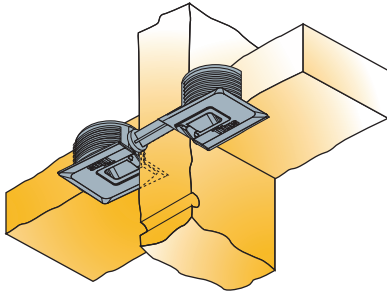

Technical and mounting details

Double-ended dowel

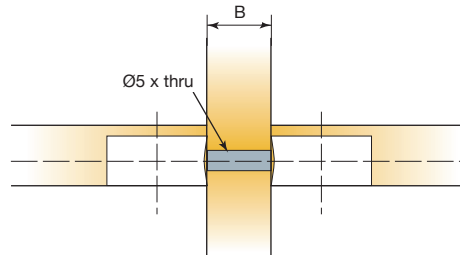
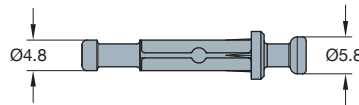

B	Item number	Zinc
Panel thickness		
16	06414 →	885
18	06413 →	885
19	06416 →	885

2500 Pcs

Made of zinc

System 6.2

End Dowels

- For 16mm, 18mm and 19mm board
- For applications with all Titus Sys 6.2 Ø20mm housings
- 'Klix' locking feature provides a strong, vibration proof connection

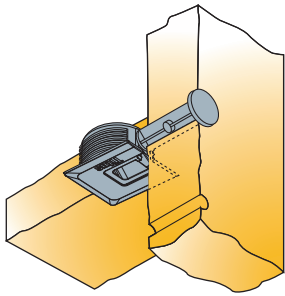

Technical and mounting details

End dowel

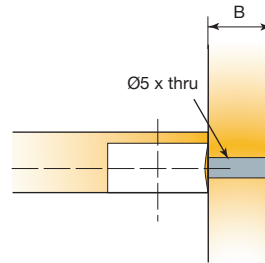
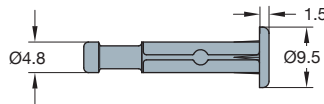

B	Item number	Zinc
Panel thickness		
16	06412 →	885
18	06411 →	885
19	06415 →	885

2000 Pcs
1000 Pcs (06411)

Made of zinc

System 6.2

20mm Knock-in Housing

- Available in 15mm/16mm and 18mm/19mm versions for drop-on and side-entry applications
- Metal cover cap option
- 'Klix' locking feature provides a strong vibration proof connection
- Compatible with all Sys 6.2 screw-in dowels and Quickfit dowels

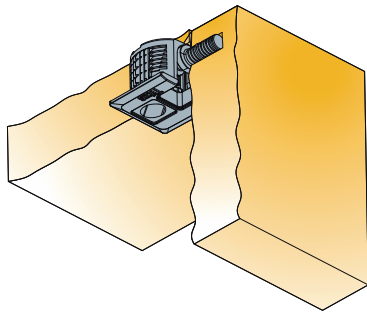

Technical and mounting details

Side-entry

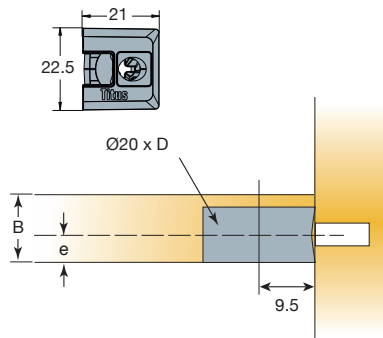

2500 Pcs

Made of plastic

Drop-on

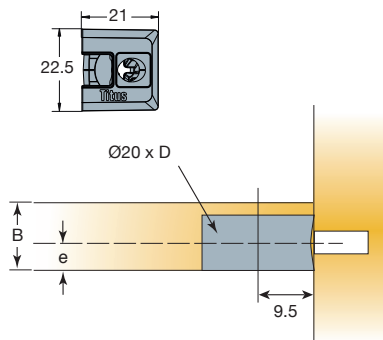

2500 Pcs

Made of plastic

e	B	D	Item number	Silver grey	Dark grey	Dark brown	White
7.75	15/16	12.5	06973 →	381	383	831	877
9.25	18/19	14	06977 →	381	383	831	877
<i>Other colours on request</i>							
7.75	15/16	12.5	06975 →	381	383	831	877
9.25	18/19	14	06979 →	381	383	831	877
<i>Other colours on request</i>							

System 6.2

Wedgefix Housing (no Inner Cam)

- Available in 15mm/16mm and 18mm/19mm versions
- Compatible with all Sys 6.2 screw-in dowels and Quickfit dowels
- Wedgefix housing allows easy customer hand assembly or factory automated insertion
- When used with Sys 6.2 Quickfit dowels this provides a true toolless fastening system

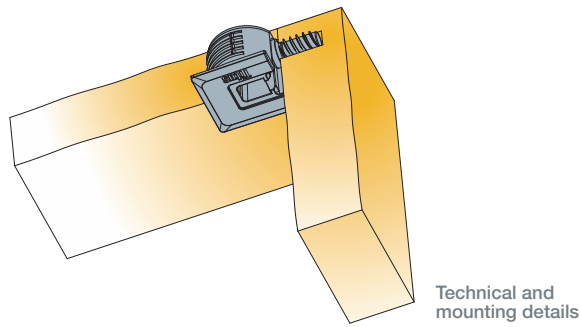

For use with screw-in dowels

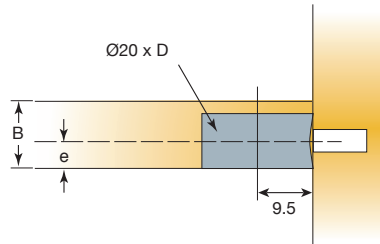
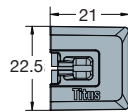

2500 Pcs

Made of plastic

For use with Quickfit dowels

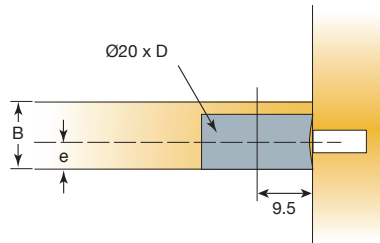
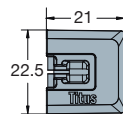

2500 Pcs

Made of plastic

e	B	D	Item number				
Panel thickness	Drilling depth			Silver grey	Dark grey	Dark brown	White
7.75	15/16	12.5	06619 →	381	383	831	877
9.25	18/19	14	06620 →	381	383	831	877
<i>Other colours on request</i>							
7.75	15/16	12.5	06621 →	381	383	831	877
9.25	18/19	14	06622 →	381	383	831	877
<i>Other colours on request</i>							

System 6.2

Add-on Cover Caps

- Metal cover caps for retrofit mounting
- Enhanced look and contemporary design
- Fits all Sys 6.2 plastic housings

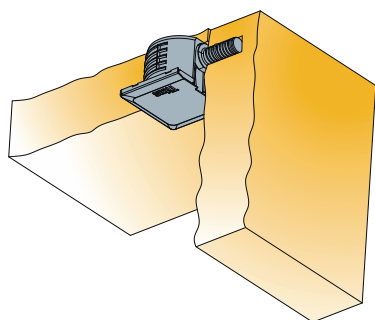

Technical and mounting details

Cover cap for 20mm housing

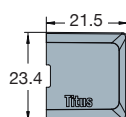

Item number

Nickel plated

Noir

06596 →

054

068

 2050 Pcs

Made of steel

System 7

Heavy Duty Connectors

System Features

A family of heavy duty cams and dowels for offices and public furniture.

- Heavy-duty cam and dowel connector with excellent pull-out and racking strength
- Designed for applications requiring high strength and high performance

- Simple and fast installation
- Suitable for materials such as pine, MDF, and chipboard
- Uses common components with standard drilling patterns
- Suitable for medium to high-value furniture as well as cost-efficient furniture

Applications



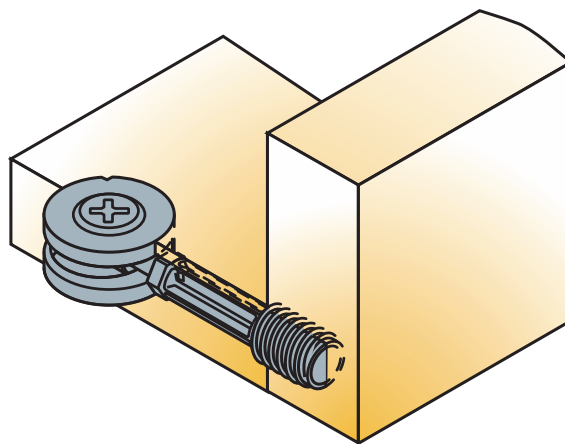

- Suitable for factory insertion and home assembly
- Heavy-duty cabinets, desks, bookcases and large wardrobes, computer furniture, modular panel systems, in-store and retail fixtures, contract office furniture, and platform-style furniture.

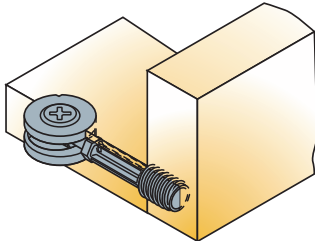

System 7

Heavy Duty Ø20mm Cam and Dowel

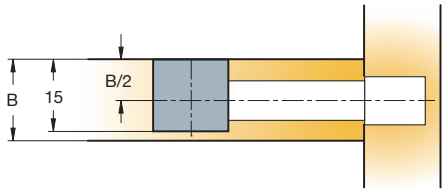
- Dowel available with Ø10mm eurothread and cam available in Ø20mm for a variety of panel thicknesses
- 'Klix' locking feature provides strong, vibration proof joint
- High strength product that eliminates the need for time consuming metal inserts

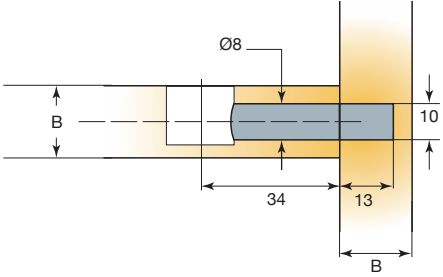





 <p>Technical and mounting details</p>	B	Item number	Zinc
<p>Cam Ø20</p>   <p>500 Pcs Made of zinc</p>	18	05409 →	885
<p>Dowel Ø7 Ø10 mm thread</p>   <p>500 Pcs Made of zinc</p>	min 18	05410 →	885

System 7

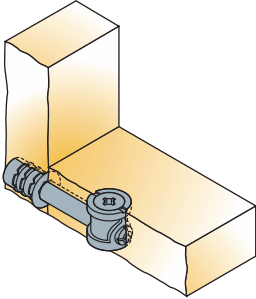
High Strength Connectors

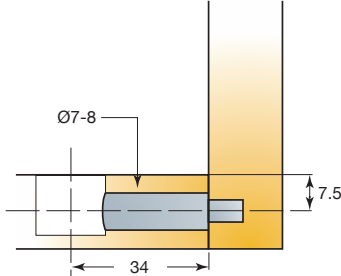
Contract Fix™ System

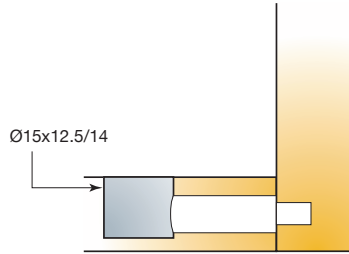
- High performance fastener
- Thread design gives repeatability
- Multi-drive recess
- Higher than average pull-up

		Item number	Zinc plated	Zinc
 <p>Technical and mounting details</p>				
<p>M6 Dowel 7x34</p>   <p>1000 Pcs Made of steel</p>		05971 →	883	
<p>Housing cylinder 15x12</p>   <p>1000 Pcs Made of zinc</p>		05960 →		885
<p>Grub screw</p>  <p>2500 Pcs Made of zinc</p>		05917 →		885











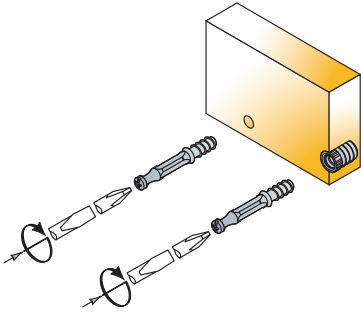

Inserts
Made of zinc

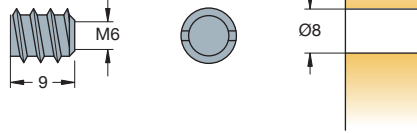
→ see page 1.70

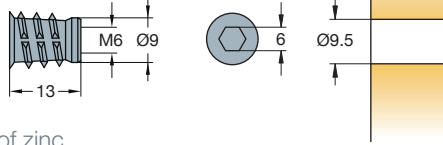
Accessories for Connectors

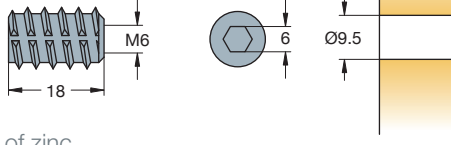
Inserts

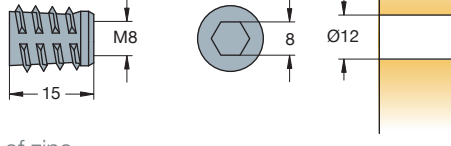
- Available in both zinc and plastic for use in various applications
- For use with various threaded dowels
- For use with various panel thicknesses
- Knock-in and screw-in versions available

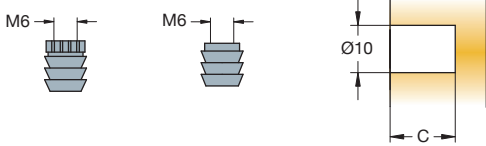
 <p>Technical and mounting details</p>		C	Drilling length for insert	Item number	Natural white	Raw
<p>Ø8 x 9</p>  <p>500 Pcs</p> <p>Made of zinc</p> 	408-3166 →		600			
<p>Ø9 x 13</p>  <p>1000 Pcs</p> <p>Made of zinc</p> 	408-3391 →		600			
<p>Ø9.5 x 18</p>  <p>1000 Pcs</p> <p>Made of zinc</p> 	408-3423 →		600			
<p>Ø12 x 15</p>  <p>1000 Pcs</p> <p>Made of zinc</p> 	408-3424 →		600			
<p>Ø10 x 13/M6 nut</p>  <p>20000 Pcs (275-4035)</p> <p>30000 Pcs (275-4058)</p> <p>Made of plastic</p> 	13	275-4035 →	200			
	11	275-4058 →	200			

Cabinet Accessories

Shelf Q-Peg

- Easy and quick installation
- Structural cabinet stability through shelf-to-panel connection
- Minimalistic appearance
- In line with the shelf surface

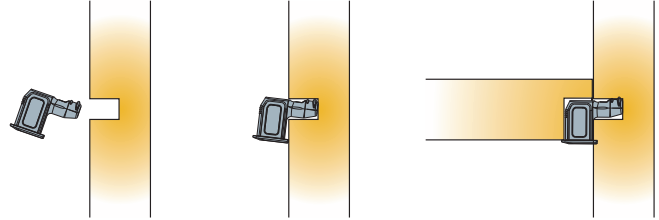

Technical and mounting details

Shelf Q-Peg Square

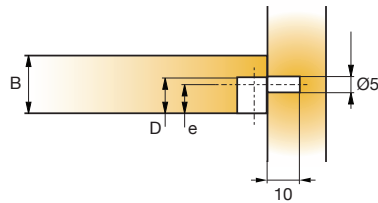
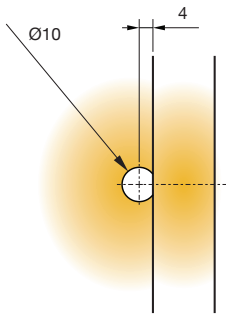
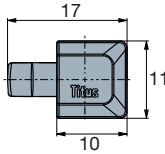
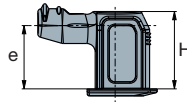

B	D	e	H			
Panel thickness	Drilling depth	Edge to pin hole center	Height	Item number	Nickel plated	Noir
18	11.5	9	11	01924 →	847	668
16	10.3	7.75	9.75	01927 →	847	668

Capacity chart

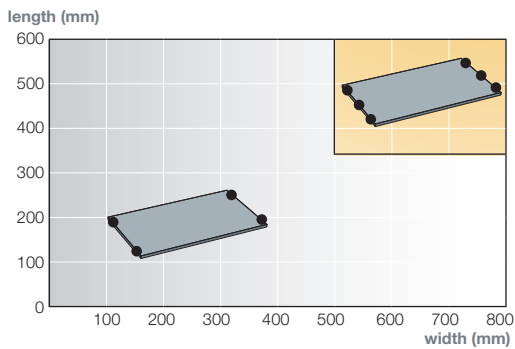







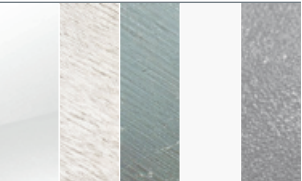
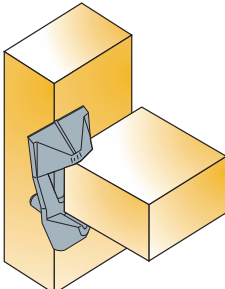

Recommended number of mounted pieces, 4 or 6 per shelf, is determined by its size in accordance with the EN 14749:2016

1000 Pcs

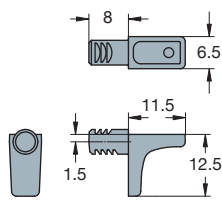
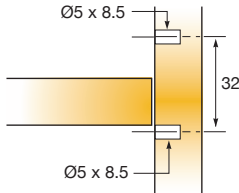
Made of zamak

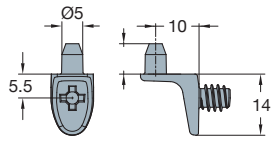
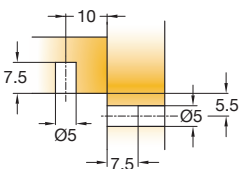
Shelf Supports

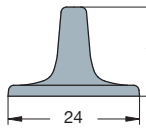
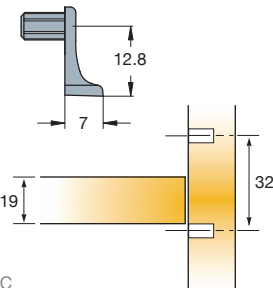

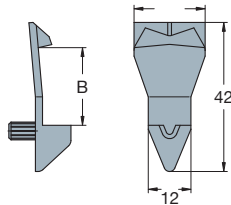
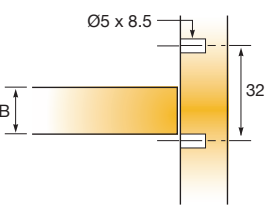



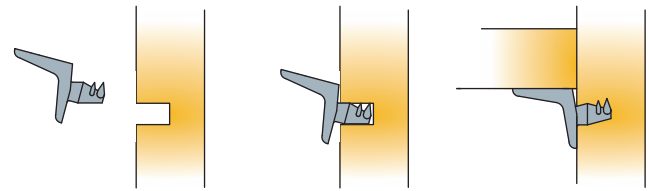

- Hold down feature traps the shelf in place for security
- Folding design allows the shelf to be post mounted in an assembled cabinet
- To suit a wide range of shelf thicknesses
- Pad for metal shelf support when using glass

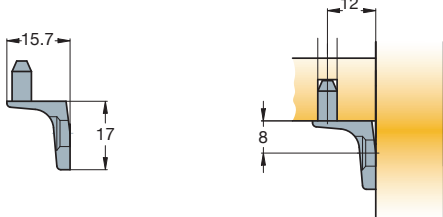
						
		Clear	Nickel	Zinc	White	Silver
		B				
Technical and mounting details		Item number				
Shelf support (push-in)    2000 Pcs Made of zinc		01825 →	847	885		
Shelf support (push-in)    2000 Pcs Made of zinc		01852 →	847			
Shelf holddown (for use with 01825)    12000 Pcs Made of plastic		01822 →				861
Shelf support retainer    4000 Pcs 5000 Pcs (01837) Made of plastic		15 01837 → 16 01838 → 16 *01828 → 18 01823 → 19 01829 → 19 01843 →	830		877	861
		<i>* American market only Other colours on request</i>				

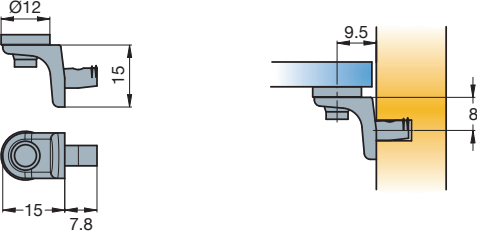
Shelf Supports

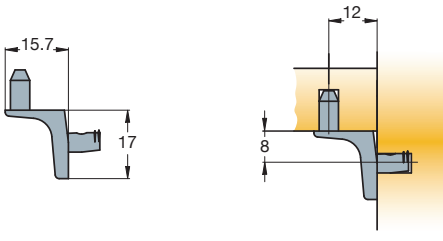
Mounting procedure:

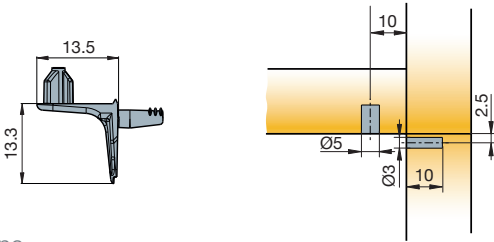

			Item number	Nickel plated
Technical and mounting details				
<p>Pin Ø5x10 (screw-on)</p>  	338-3687 →	650		
 1000 Pcs <p>Made of zinc</p>				
<p>For glass shelves (rock-in)</p>  	338-9721 →	860		
 1000 Pcs <p>Made of zinc and plastic</p>				
<p>Pin Ø5x10 (rock-in)</p>  	338-3686 →	650		
 1000 Pcs <p>Made of zinc</p>				
<p>Shelf support Ø3mm with pin</p>  	01912 →	847		
 2000 Pcs <p>Made of zinc</p>				

Shelf Supports

		Technical and mounting details	Item number	Nickel plated
Shelf support with pin			01910 →	847
 2000 Pcs	Made of steel			
Shelf support			01911 →	847
 2000 Pcs	Made of steel			
Shelf support with pin			01916 →	847
 2000 Pcs	Made of steel			

Joining Plates

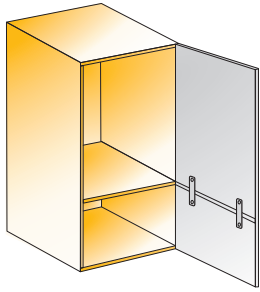

- Rigid and strong
- No pre-drilling
- Spacer pegs provide an even 2mm gap
- Sleek design



Technical details

Item number

Nickel plated

Joining plate 105mm

360-1222 →

054

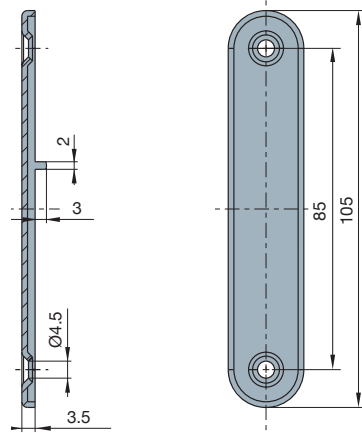

500 Pcs

Made of steel

Joining plate 43mm

360-1230 →

054

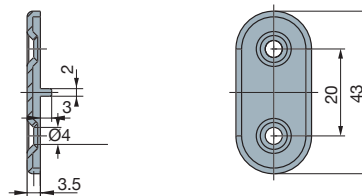

1000 Pcs

Made of steel

Fixing screw

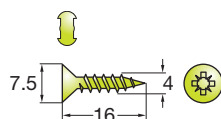

Chipboard screws
820-6328-050

10000 Pcs

Backfix Connectors

- Push-in design
- No tools required for Backfix insertion
- The handle acts as a stop during locking, providing greater accuracy and speed of insertion
- Barbs provide a quality fastener for rigid cabinet construction

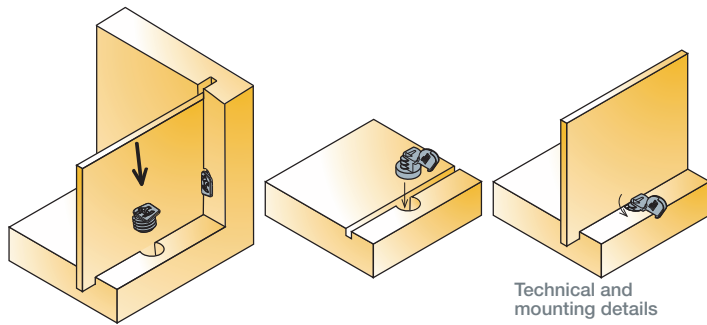

Item number

Zinc

Corrosil

Backfix 2.0

02254 →

885

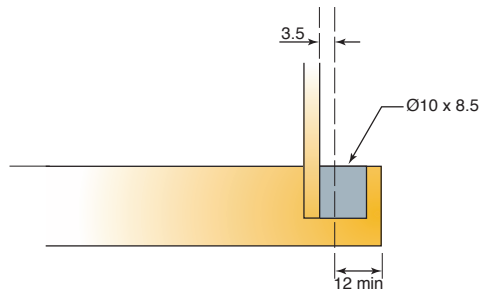
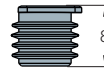
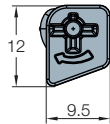

1000 Pcs

Made of zinc

Hardboard
Backfix-no tools

02154 →

885

897

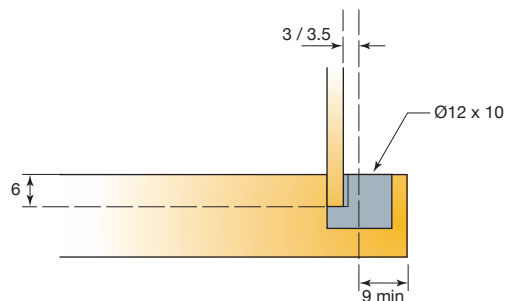

1000 Pcs

Made of zinc

Back Wall Connectors

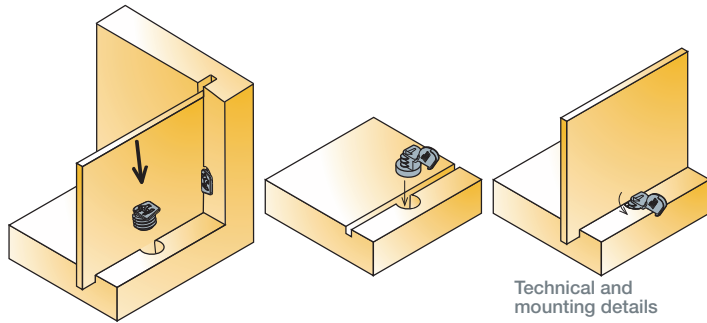

Technical and mounting details

Item number

Nickel plated

Rear wall connector long

353-3649 →

650

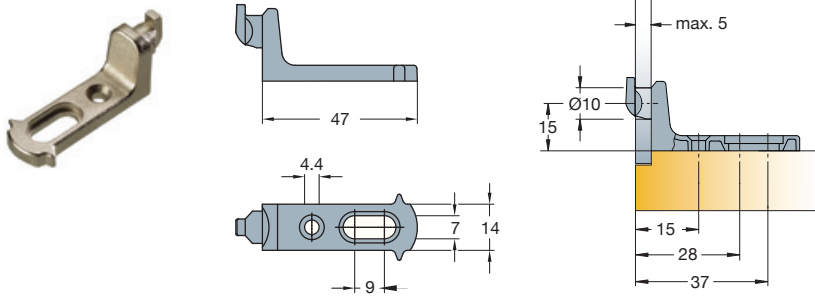

 500 Pcs

Made of zinc

Rear wall connector short

353-3650 →

650

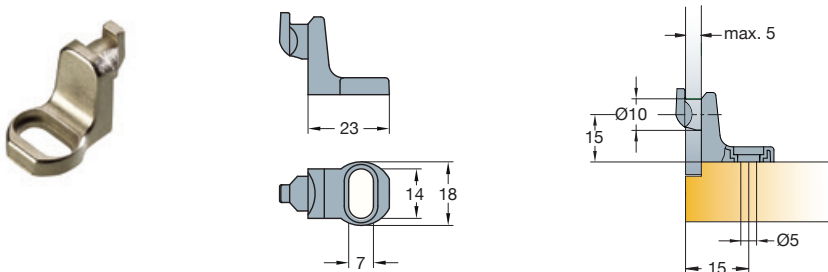

 500 Pcs

Made of zinc

Panel Brackets

- To be used to fix face frames to carcasses without additional drilling to cabinet
- Designed for carcase side panel of 18mm thickness
- Edge to hole centre = 28mm
- Easier fixing of frames due to parts that remain in holes once inserted

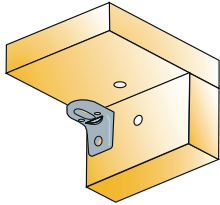

Technical and mounting details

Item number

Nickel plated

Zinc

90° Bracket (screw-in/rock-in peg)

02111 →

847

885

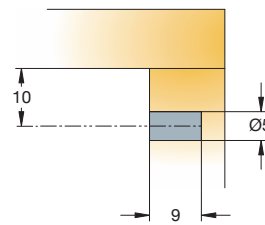
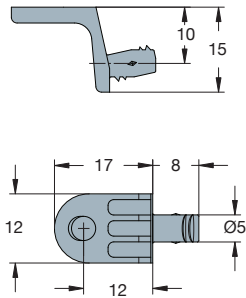

1000 Pcs

Made of zinc

90° Bracket (screw-in)

02110 →

847

885

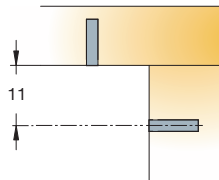
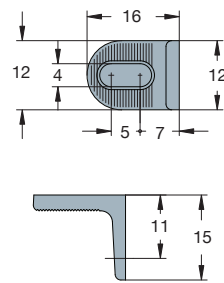

1000 Pcs

Made of zinc

Corner bracket (rock-in)

02133 →

885

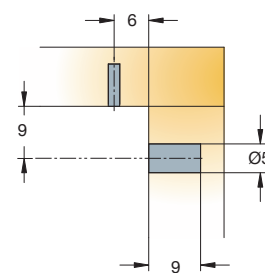
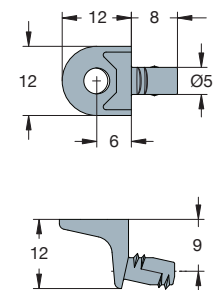







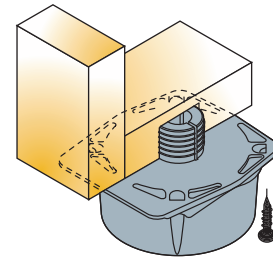

1000 Pcs

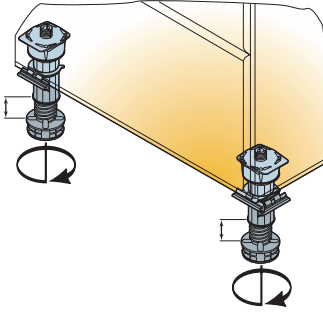
Made of zinc

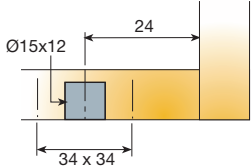

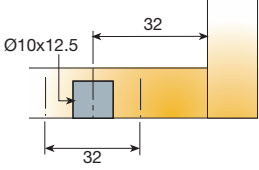
Adjustable Cabinet Legs

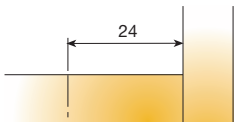
Leg Top Fixes



		Technical and mounting details	Item number	Black
Rivet fix	Regular		02560 →	835
	Heavy duty		*02630 →	835
<i>* American market only</i>				
				
 200 Pcs	Made of plastic			
Socket fix (knock in)			02558 →	835
				
 200 Pcs	Made of plastic			
Socket fix (screw on)			02559 →	835
				
 200 Pcs	Made of plastic			

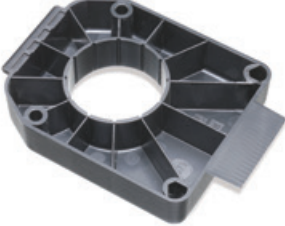





- Lip provides additional support to end panel and gives extra strength
- The side fix has twin dowel mounting for positive location
- Rivet fix design gives quick fastening of socket
- Choice of dowel or screw on sockets
- Invert second clip for corner plinth fixing

Technical and mounting details		A	D	B1	Item number	Black
		Drilling diameter	Drilling depth	Drilling distance		
Leg top  100 Pcs Made of plastic	(4 screws) screw on	3	6	64 x 64	02575 →	835
	(4 dowels + lip) dowel/lip	10	12.5	64 x 64	02582 →	835
	(4 screws + lip) screw/lip	3	6	64 x 64	02579 →	835
	2 dowels/2 screws	10/3	12.5/6	64 x 64	*02669 →	835
	Screw on	3	6	64 x 64	*02671 →	835
	Dowels	10	12.5	64 x 64	*02672 →	835
					* Asian market only When using leg top, you must use foot with 01373 clip → see page 3. 8	
Rivet fix/skid  200 Pcs Made of plastic					02663 →	835
Rivet fix/ no rivet  200 Pcs Made of plastic					*02642 →	835
					* Asian market only	

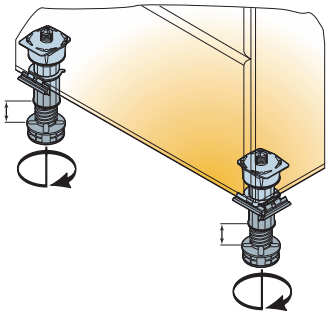
Adjustable Cabinet Leg Range

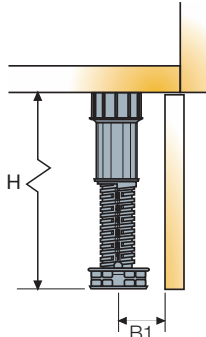
Adjustable Leg, Extension and Foot

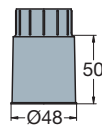
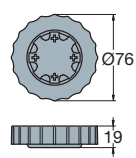
- Legs are supplied assembled at a pre-set height
- Wide adjustment range to fit all common plinth heights
- Jacking point adjustment feature
- Simple push on design to sockets

 Technical and mounting details		B1	H	Item number	Black	
		Drilling distance	Fitting height adjustment			
Adjustable leg  						
			24	60-90	02570 →	835
			24	92-152	02549 →	835
			24	92.5-150	*02666 →	835
			24	92-150	*02648 →	835
			24	125-185	*02653 →	835
	Big foot		38	92-150	*02699 →	835
	Big foot		38	125-185	*02706 →	835
* Asian market only						
 100 Pcs (02570) 200 Pcs	Made of plastic					
Leg extension  			02571 →	835		
 200 Pcs	Made of plastic					
Fixed foot  			02569 →	835		
			*02574 →	835		
* American market only						
 200 Pcs	Made of plastic					

Adjustable Cabinet Leg Range

Plinth Clips and Fox Clip

- Spring design eliminates the need for drilling and fits into any position on plinth
- The screw in version can sit in variable plinth positions
- When taking plinth around the corner, the fitting is reversible

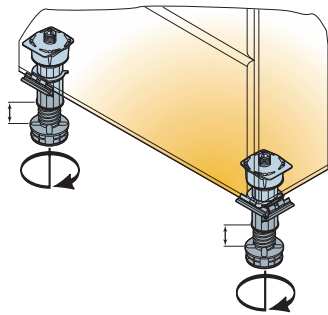

Technical and mounting details

Fox clip

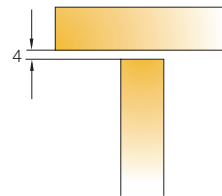

1000 Pcs

Made of plastic

Plinth clip 38 screw

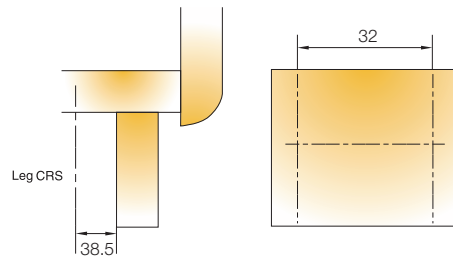

500 Pcs

Made of plastic

Plinth clip 24 knock on

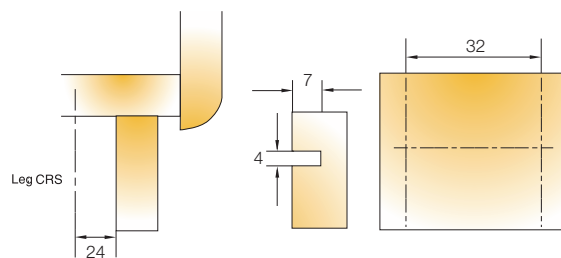

600 Pcs

Made of plastic

Plinth clip 24 screw on

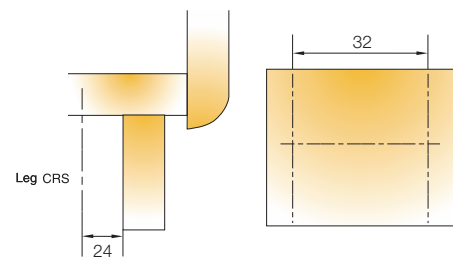

600 Pcs

Made of plastic

Item number

01373 →

Natural

846

Black

835

02578 →

835

*02710 →

835

* Asian market only

02523 →

835

02634 →

835

Drawer Solutions

Drawer Front Adjuster (DFA)

- Multi-direction adjustment
- Locking screw to fasten
- Independent of drawer system
- One piece housing

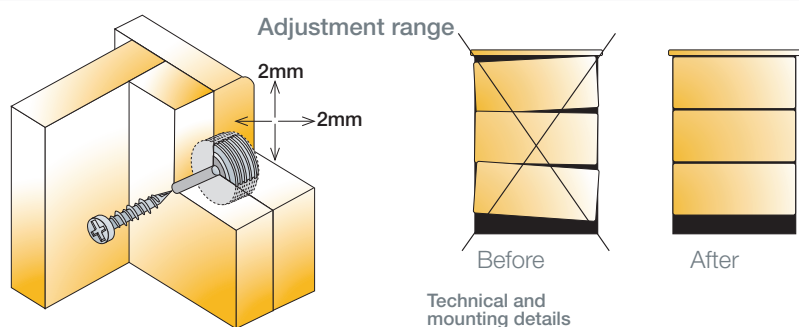

	Dark brown	Black	Nickel	White

DFA housing

Item number	06308 →	831		877
-------------	---------	-----	--	-----

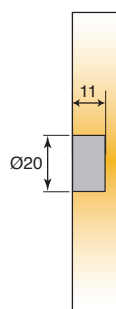

2500 Pcs

Made of plastic

DFA housing

*06310 →	831		877
----------	-----	--	-----

*06309 →	831		877
----------	-----	--	-----

*00033 →		847	
----------	--	-----	--

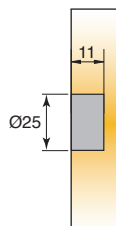
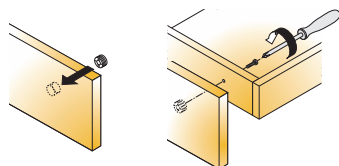

2500 Pcs

Made of zinc, plastic

*American market only
*06309 does not include screw

