

Titus Group  
Technical Catalogue  
and Manual

**Titus**



**Furniture  
Fittings  
Systems**

**2026**



# Important Information

## Technical information

Our catalogue strives for information accuracy, but as our products are continually updated, we recommend verifying the latest specifications before placing an order. We retain the right to make unannounced changes due to ongoing product improvements.

## User responsibility

Users are responsible for ensuring that our hardware suits their intended purpose. We suggest conducting appropriate tests and reaching out to our technical representatives for assessment.

## Intellectual property

Titus Group possesses global intellectual property rights, including trademarks, patents, copyrights, designs, illustrations, drawings, and the proprietary knowledge embedded in our products' design and production. We also respect competitors' rights and other relevant product design rights. Our products are not known to infringe upon any intellectual property rights, but we take infringements seriously and will vigorously defend our rights within the bounds of the law.

## Non-preferred articles

Items marked with \* in the catalogue are non-preferred and may have extended delivery times.

## Trademarks

Titus and Titusonic are registered trademarks of Titus International Ltd. Lama is a registered trademark of Titus d.o.o. Dekani. WoodWelding is a registered trademark of WW SA.

# Contents

---

1

---

2

---

3

---

4

---

5

## Cabinet Connectors

1.1

- System 1
- System 2
- System 3
- System 4
- System 5
- System 6
- System 6.2
- System 7
- Cabinet Accessories

## Concealed Hinges and TouchControl Solutions

2.1

- Information
- T-type hinges
- S-type hinges
- B-type hinges
- Glissando Soft Closing Systems
- TouchControl Solutions

## Tekform Slimline+ Drawer

3.1

- Tekform Slimline+ Drawer
- Tacto 2.0 for Slimline+ Drawer

## Soft Closing Systems for Doors and Drawers

4.1

- Titusoft WD
- Titusoft MD
- Titusoft FF
- Set 200s

## About Titus Group

5.1



# Cabinet Connectors

# Cabinet Connectors

## Product Guide

Page

### System 1

Fittings for rigid assembly systems

a highly cost-effective and rigid assembly system for factory, consumer and home assembly

1.9

### System 2

Fittings for face-boring applications

face boring applications that provide a tolerant efficient assembly

1.11

### System 3

Fittings for face and edge boring

two component rigid face and edge drilling fastening

1.13

### System 4

Fittings for face-boring only

a range of low-cost one-piece fittings for high volume home assembly applications

1.15

### System 5

Cams and dowels

a comprehensive range of cam and dowel connecting fittings for all cabinet applications

1.21

Page

## System 6

Quickfit-Expando connectors	face boring expanding connectors for all cabinet applications	1.45
-----------------------------	---	------

## System 6.2

Expando connectors for face boring	face boring connectors for closets and wardrobes	1.57
------------------------------------	--	------

## System 7

Heavy duty cams and dowels	high quality fittings for offices and public furniture	1.67
----------------------------	--	------

## Cabinet Accessories

Complementary and structural support fittings	Shelf Q-Peg	1.73
	Shelf supports	1.74
	Joining plates	1.77
	Backfix	1.78
	Back wall connectors	1.79
	Panel brackets and wall connectors	1.80
	Adjustable cabinet legs	1.81
	Drawer front adjuster	1.85

# Connectors

## Information

### Why Choose Titus?

#### Titus connectors add value to furniture and to furniture manufacturing

Titus connectors improve the quality of furniture and lower the cost of manufacturing and assembly while ensuring a high degree of customer satisfaction.

#### The most advanced range of connectors available on the market

**Precise and efficient** product design. **The broadest possible range of drilling tolerances** ensures reliable assembly and consistently strong joints. **'Klix'** locking feature, the engagement of interlocking teeth on cam and dowel, to prevent joint loosening in service or transit.

**Expanding function** provides degrees of variation in out-of-tolerance drillings ensuring stronger joints and improved quality of furniture.

**Twinstart thread** for faster and more stable insertion.

**Depth stop collar** prevents over-insertion.

**Firm tightening** for greater confidence in use.

**Cam locks at 230°** assuring smooth tightening action and greater dowel pull-up.

**Quickfit** for hand dowel insertion.

**Quickfit TL5**, new generation steel dowel with quickfit expando technology for insertion in Ø5mm dowel holes.

**Quickfit TL2, TL4** with the built-in self adjustment feature for higher drilling tolerances.

**Quickloc** one piece fitting for faster assembly with integrated expanding cam and dowel.

**Zinc+steel dowel** for optimal strength and performance.

**Precise dowel manufacturing** high precision of zinc and strength of steel assures 100% dimensional accuracy.

#### Easy and quick consumer friendly self-assembly of furniture

Self-assembly furniture offers consumers good value and instant availability of products.

With the aim of providing consumer with simpler instructions, fewer parts and an easier assembly process, Titus has significantly reduced and simplified the number of fittings traditionally required in furniture production.

Titus connectors provide consumers with easy assembly and furniture producers with increased productivity:

- reduced number of assembly parts
- easy assembly instructions
- security of packed parts during transit

**CAF** Quick & Easy

Consumer Assembly Friendliness

### Easy and Quick Furniture Assembly

#### CAF formula

CAF=Consumer Assembly Friendliness

Titus CAF formula provides a comparative measure for customer satisfaction. By using it manufacturers are able to evaluate their products internally or against those of their competitors.

While offering consumers easier and faster assembly, there are obvious advantages also for furniture manufacturers – buying, counting, bagging and stocking of fittings can be greatly reduced.

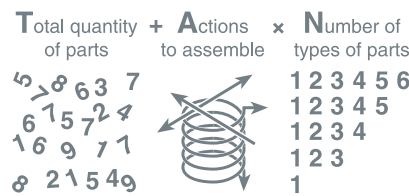

$$(T+A)N = CAF$$

Minimise the numbers in the Titus CAF™ formula to achieve:

- High customer satisfaction
- Improved productivity
- Higher profits

#### How does it work?

Comparative CAF scores to assemble a hand held demonstrator

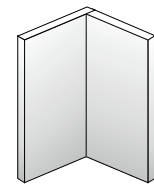

	T	A	N	CAF
Connecting screw (traditional assembly)	4	38	3	126
Cam & dowel with single start thread	6	21	4	108
Cam & dowel with twinstart thread	6	15	4	84
Cam & TL2 dowel (self-assembly)	6	7	4	52
Cam & TL2 dowel (factory pre-inserted)	2	3	2	10
Quickloc	2	3	1	5
Fully assembled demonstrator	1	0	1	1

# Cabinet Connectors

## CAF Quick & Easy

Consumer Assembly Friendliness

### Consumer Assembly Friendliness - CAF principle

- Quick assembly with less parts and less assembly steps
- Simple instructions
- Easy and intuitive assembly

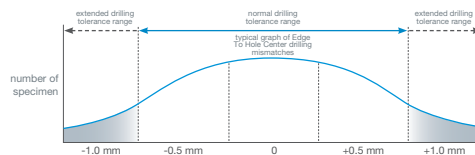

### High drilling tolerances

- Optimal cabinet joint even in cases of inaccurate drilling
- In-built self adjustment feature ensures perfectly aligned and precise joints

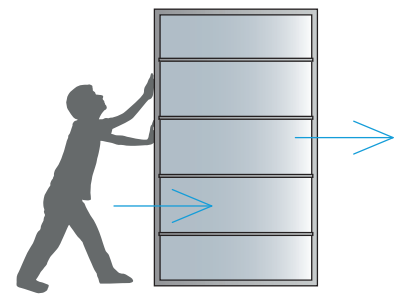

### Strong and reliable joints

- High performance joints
- Great cabinet strength even at repeatable assembly or disassembly
- Enhanced resilience even in more demanding applications in tall wardrobes or office furniture

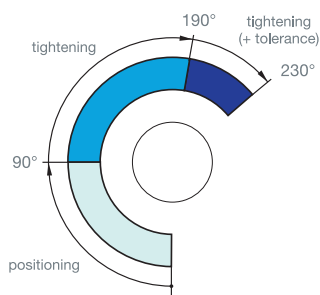

### Reliable and comfortable locking

- Smooth and firm tightening at 2 o'clock lock
- Great dowel pull-up for optimal performance
- Strong and reliable joint

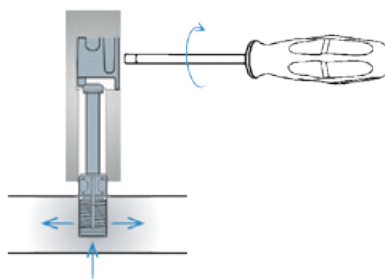

### Expando function

- Expanding sleeve on dowels assures high resistance to pull-out
- Firm fixing in the dowel hole

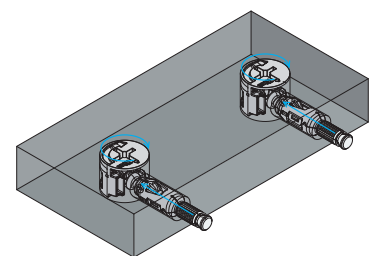

### Factory pre-insertion

- With Quickfit TL5 and TL2 dowels
- Perfect for RTA market: easier packing and transportation
- The insertion of cams and dowels can be automated using Lama FastFit machine

# System 1

## Fittings for Rigid Assembly Systems

### System Features

#### Double locking carcass screw

- Zinc diecast for precision
- Titus Double locking carcass screw makes an almost invisible connection
- Collar under the head to pull panels together
- 2nd 'lower' thread pulls against a 'faster' thread to provide maximum connection force and prevents overdriving of fastener
- Almost invisible in position
- Head can be 'fastcapped' or filled

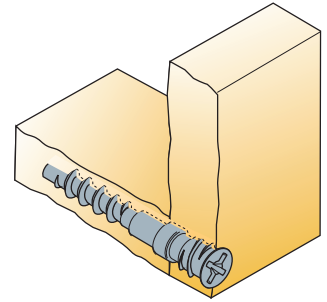

# System 1

## Fittings for Rigid Assembly Systems

### Double Locking Carcase Screw

- High performance from widely spaced primary thread
- Finer secondary thread provides additional holding power and positive stop (no override)
- Increased support for vertical panel is gained from the funnel head with collar at its base
- One-piece fitting

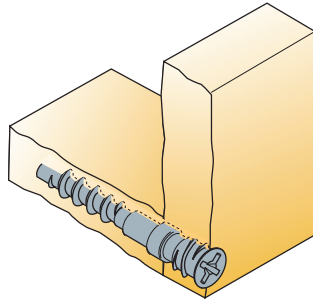

Technical and mounting details

Item number

Zinc

Screw 6x42

00180

885

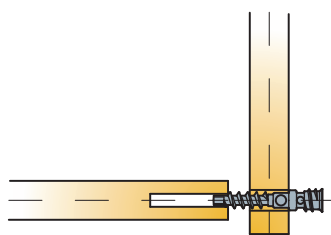
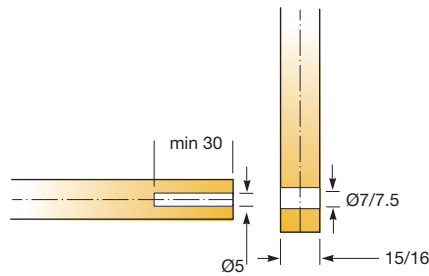
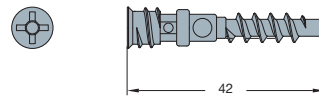

1. Insert screw to shoulder in face board

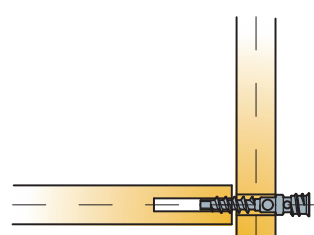

2. Screw into Ø5mm hole

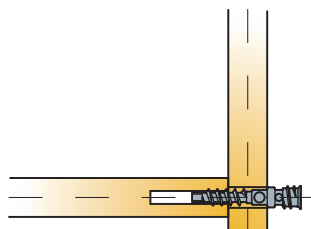

3. Board joint pulled up by collar on screw

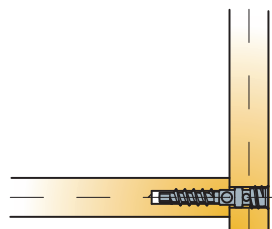

4. Board locked in place by screw

1000 Pcs

Made of zinc

# System 2

## Fittings for Face-boring Applications

### System Features

A family of face boring only fasteners with wide tolerances and the high clamping force of an angled screw.

- Factory or site component installation
- Wide tolerances
- Face boring only
- For kitchen, furniture storage, office and store fixture applications
- Non twist rail fastener versions
- Screw fastening or hammer insertion

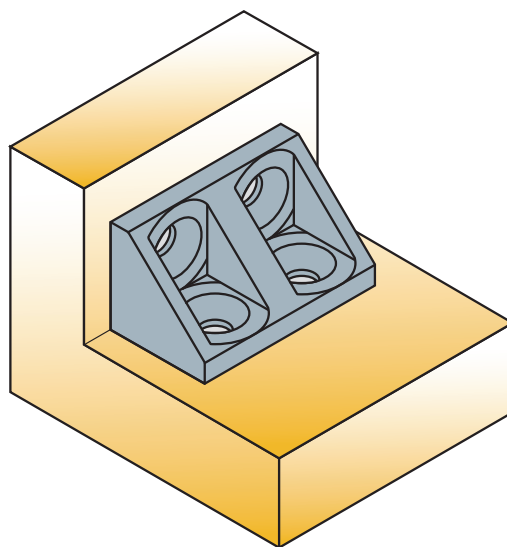

# System 2 Fittings for Face-boring Applications

- Range of fixing blocks for multiple applications
- Face drilling only required
- Durable plastic material is flexible providing greater holding power
- Choose screw fastening or hammer insertion

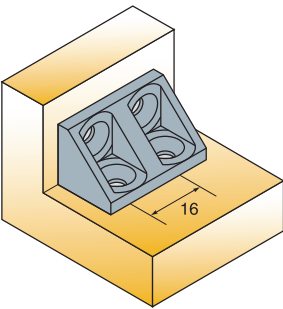

Technical and mounting details

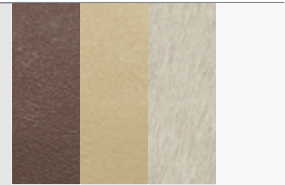

Item number	Dark brown	Light brown	Ivory	White
-------------	------------	-------------	-------	-------

## Rail fastener

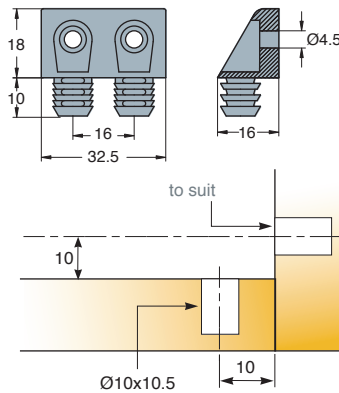

02075 →	831	867		877
---------	-----	-----	--	-----

2000 Pcs

Made of plastic

## Housing (no nose)

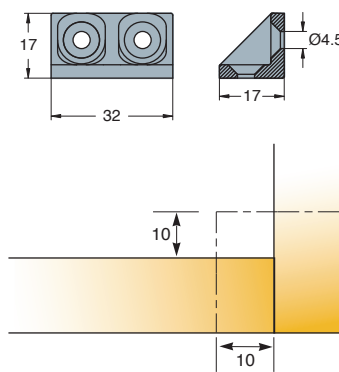

02077 →			875	877
---------	--	--	-----	-----

2000 Pcs

Made of plastic

## Modesty block

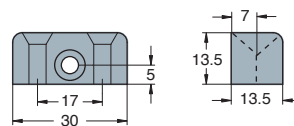

*06073 →		867		877
----------	--	-----	--	-----

\*European market only

1500 Pcs

Made of plastic

# System 3

## Fittings for Face and Edge Boring

### System Features





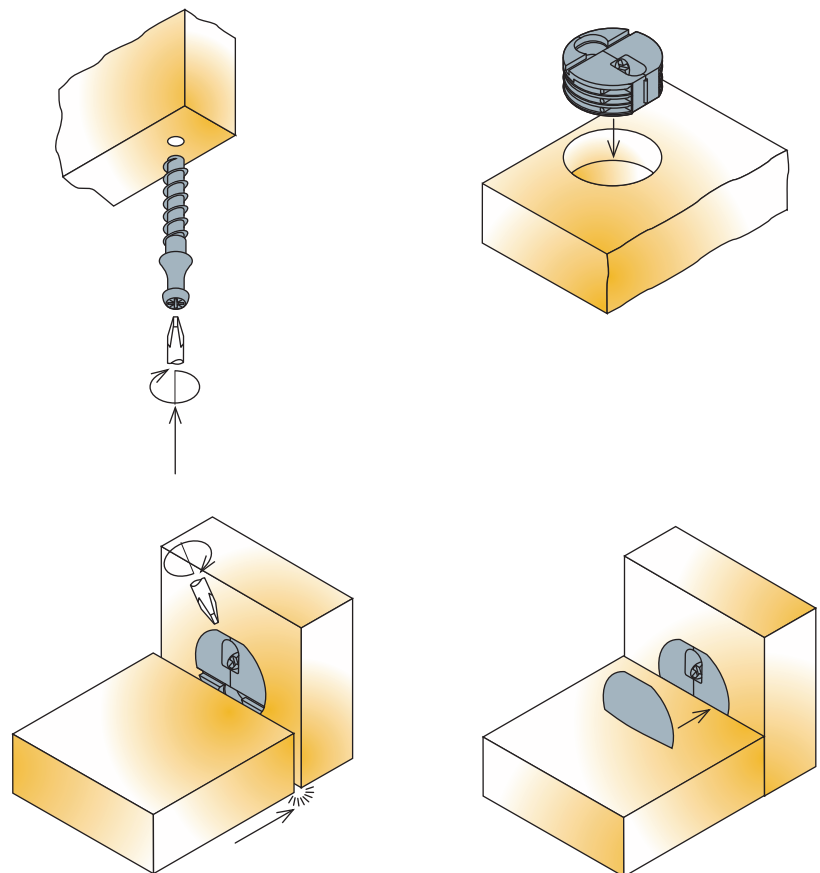

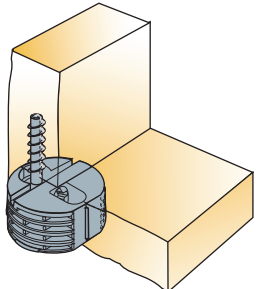

Titus System 3 is a two component rigid face and edge drilled fastening with half turn to fasten. System 3 offers almost full concealment and wide tolerances in use.

- Automatic or in-factory placement
- Pre-location pin ensures ease of assembly
- Less than one turn of a screwdriver to fasten
- Shelf edge installation of pin means maximum shelf cut size tolerance
- Can be used on 12mm shelf panels
- No loose parts for maximum convenience in RTA
- Drawer front fixing, cabinet construction

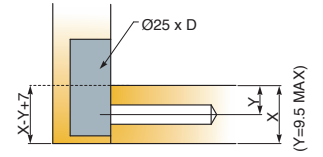

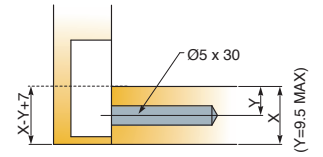
# System 3 Fittings for Face and Edge Boring Concealed Housing

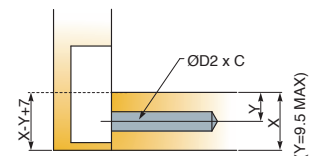
- One turn locking system reduces assembly time, both in the factory and home
- Pre-assembly feature for consumer convenience
- Choice of dowels to suit drilling
- Hi-Lo screw feature for faster insertion

Technical and mounting details		C	D	D2						
		Drilling length for dowel	Drilling depth for housing	Drilling diameter for dowel thread	Item number	Black	Zinc plated	Dark brown	Yellow passivate	White
 <p>Technical and mounting details</p>										
<p><b>Housing assembly</b></p>  <p>X, Y - depends on board thickness</p>  <p>Made of plastic or zinc, plastic</p> <p>2500 Pcs</p>		12.5			<b>03118</b> →	835		831		877
<i>Other colours on request</i>										
<p><b>Screw dowel Ø5</b></p>  <p>X, Y - depends on board thickness</p>  <p>Made of zamak</p> <p>1000 Pcs</p>		30		5	<b>03168</b> →			883		
<p><b>Screw dowel Ø3</b></p>  <p>X, Y - depends on board thickness</p>  <p>Made of steel</p> <p>5000 Pcs (03180) 4000 Pcs (03181) 1000 Pcs (03090)</p>		11		3.75	<b>03181</b> →					881
		9		3	<b>03180</b> →					881
		25		3	<b>*03090</b> →			883		
<i>*American market only</i>										
<p><b>Cover cap</b></p>  <p>Made of plastic</p> <p>15000 Pcs</p>					<b>03150</b> →	835				877

# System 4 Fittings for Face-boring Only

## System Features

Cost effective one piece fittings with face boring benefits

- Flush and block components
- Face-boring only
- Good tolerances
- One piece connectors
- Angledriv versions fastening with maximum driving power and flexibility
- Quickloc™ versions need only one turn to tighten for fast assembly
- Foolproof consumer home insertion

### Quickloc™ One-piece connector

The integrated housing and dowel make Quickloc™ the most user-friendly and tolerant product available.

- High degree of drilling tolerance
- Push-in design
- Tool-free insertion
- Integrated expanding housing and dowel provide consistently stronger joints
- 'Klix' locking system

### Quickloc™ Assembly

1. Press Quickloc into the face board

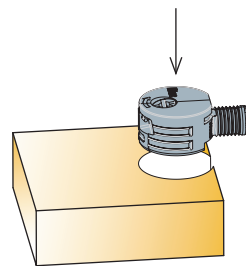

2. Assemble the panels

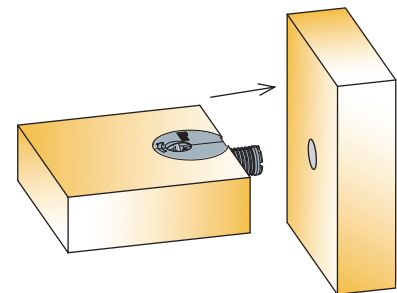



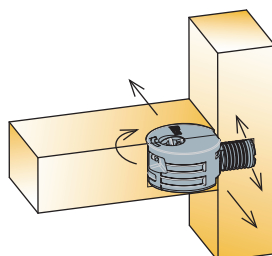





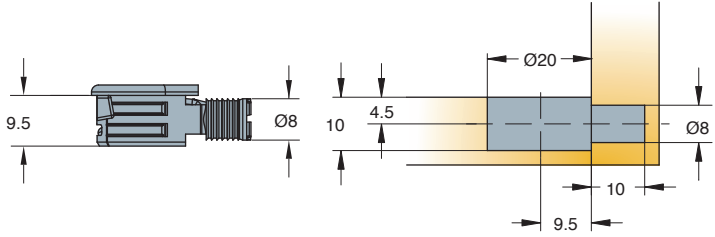

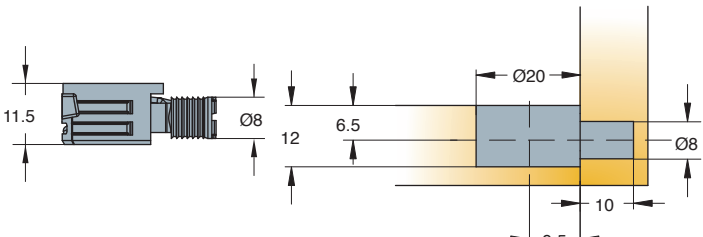
3. Tighten in less than one turn

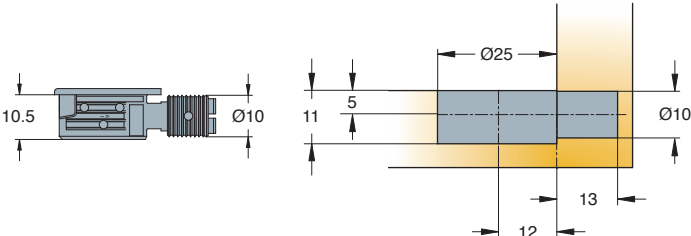

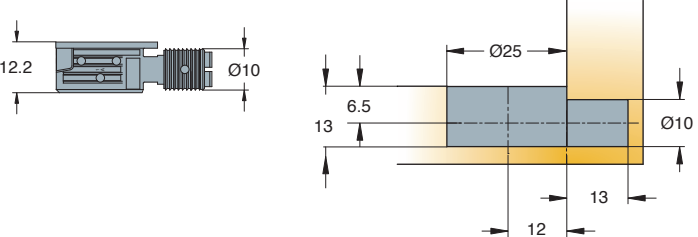
# System 4 Quickloc™ One Piece Expanding Connector

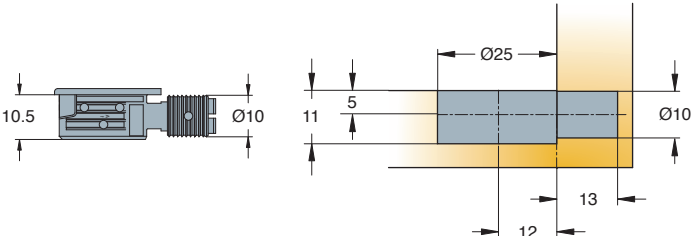
- An innovative, one-piece connector, capable of hand insertion
- Highly tolerant and tightens in less than one turn
- Face-bored product
- Offers a high degree of drilling tolerance and is the only connector of its type to provide pull-up of cabinet panels when tightened

Technical and mounting details		Color options			
		Dark brown	Black	White	
		Item number	Dark brown	Black	White
<b>Quickloc Ø20 flanged</b> 		06803 →	831	835	877
 2500 Pcs	Made of zinc, plastic				
<b>Quickloc Ø20 flush</b> 		06806 →	831	835	877
 2500 Pcs	Made of zinc, plastic				
<b>Quickloc Ø25 flanged</b> 		06802 →	831	835	877
 1500 Pcs	Made of zinc, plastic				
<b>Quickloc Ø25 flush</b> 		06839 →	831	835	877
 1500 Pcs	Made of zinc, plastic				

# System 4

## Fittings for Face-boring Only

### Flushbloc™ / Flushfix™

- The Angledriv screw provides high level of tolerance
- Face drilling only required
- Corner joint and shelf fixing options

Technical and mounting details		Item number	Brown beige	Black	Silver	White	Zinc
<b>Flushfix™</b>  		<b>02161</b> →	806		861	877	
 2500 Pcs      Made of plastic		<i>Other colours on request</i>					
<b>Flushbloc™ with screw</b>  		<b>02193</b> →		835		877	
 2000 Pcs      Made of zinc and plastic		<i>Other colours on request</i>					
<b>Flushbloc™ assembly</b>  		<b>*02190</b> →		835		877	
 2500 Pcs      Made of plastic		<i>* American market only</i> <i>Other colours on request</i>					
<b>Angledrive screw for use with Flushfix™</b>  		<b>00021</b> →      round head <b>00022</b> →      flat head					885
 2000 Pcs      Made of zinc							









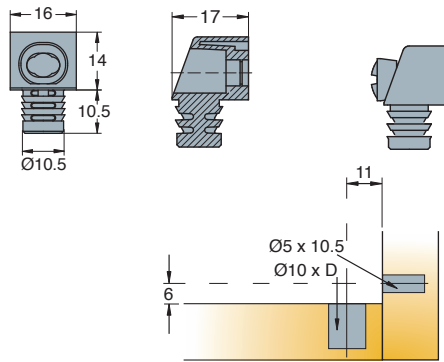

# System 4

## Fittings for

### Face-boring Only

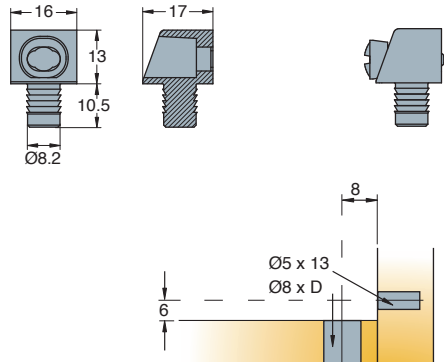
#### Minibloc™ / Twinbloc™

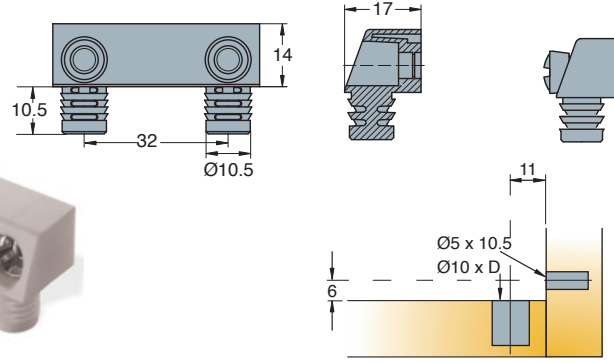
- One-piece connector range
- Face drilling only required
- Easy to use, foolproof home insertion
- Angledriv screw tolerates good levels of inaccurate drilling increasing consumer confidence

Technical and mounting details		D					
		Drilling depth	Dark brown	Black	Silver	White	
		Item number					
<b>Minibloc Ø10</b> 		11	02107 →	831	835	861	877
		11	* 02120 →	831	835	861	877
 2500 Pcs (02107)  3000 Pcs (02120) Made of zinc, plastic		* Assembly with screw Other colours on request					
<b>Minibloc Ø8</b> 		11	02141 →		835	861	877
		11	* 02144 →		835		877
 3000 Pcs Made of zinc, plastic		* Assembly with screw * European market only Other colours on request					
<b>Twinbloc Ø10</b> 		11	02130 →		835	861	877
		11	* 02139 →		835		877
 1000 Pcs Made of zinc, plastic		* Assembly with screw Other colours on request					

# System 4 Fittings for Face-boring Only Cambloc

- Screw-on and knock-in versions are available
- Plastic housings are available in different colours
- Quick and intuitive assembly when fittings are pre-mounted on furniture

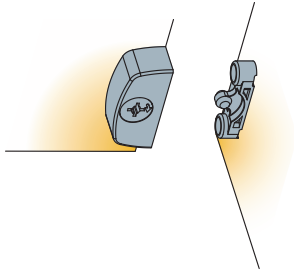

Technical and mounting details

## Screw-on

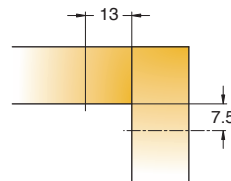
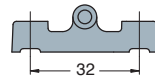
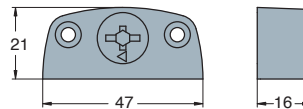

Item number

279-9187 →

Zinc plated  
+ white housing

960

Zinc plated  
+ brown housing

970

Zinc plated  
+ black housing

980

1000 Pcs

Made of plastic, zinc cam



# System 5 Cams and Dowels

## System Features

### The most advanced cam and dowel range

Titus System 5 is a comprehensive range of cam and dowel connecting fittings with 'Klix' and Quickfit features for all cabinet applications: panel-to-panel, panel-to-hollow profile, back-to-back

#### Dowels

- **Quickfit TL5, 'Full metal jacket'**  
a high performance Quickfit dowel for use in multiple wooden materials
- **Quickfit TL2, TL4, TL5 dowels**  
a unique solution for factory pre-insertion, high level of drilling tolerances
- **Quickfit dowels**  
quick hand insertion, easy assembly
- **Diecast dowels (zinc)**  
precise manufacturing, optimal shape and design
- **Turned dowels (steel)**  
'traditional' design, smooth surface, best strength performance
- **Combi dowels (zinc and steel)**  
high precision of zinc, strength of steel, 100% dimensional accuracy and optimal performance

### Titus 'Klix'<sup>TM</sup>

Titus 'Klix' locking system ensures the engagement of the interlocking teeth on cam and dowel providing:

- vibration-proof joint
- rigid construction that will not loosen in service or transit

### Dowel insertion time comparison

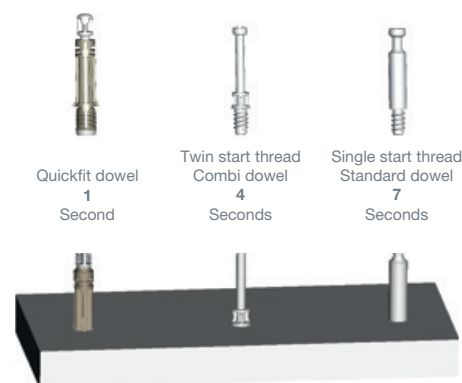

### 2 o'clock lock Smooth closing

Linear cam profile assures smooth, firm tightening action and greater pull-up. The cam always locks at 2 o'clock lock (230°), enabling greater consumer confidence in use while improving furniture quality.

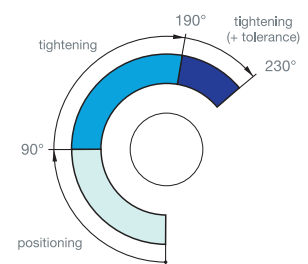

## Drilling tolerances

Optimal performance and perfect joint even with inaccurate drillings.

Zinc/Combi dowel

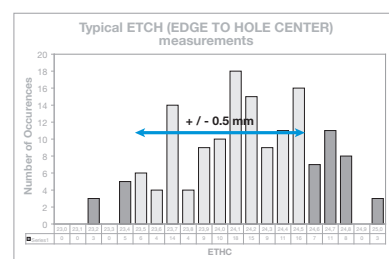
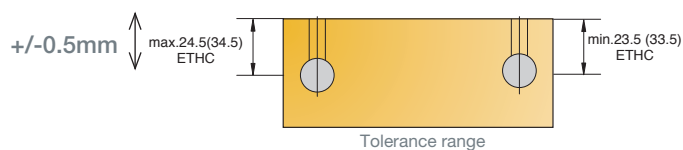

Quickfit TL5 dowel, Quickfit TL2 dowel

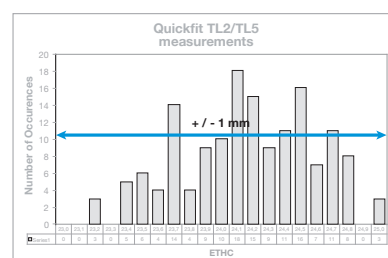
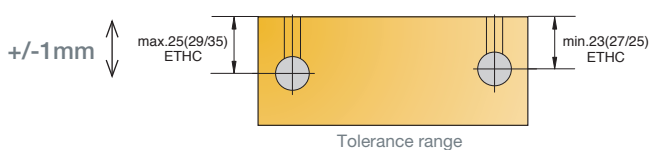

Quickfit TL4 dowel

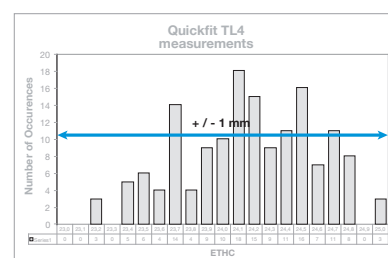
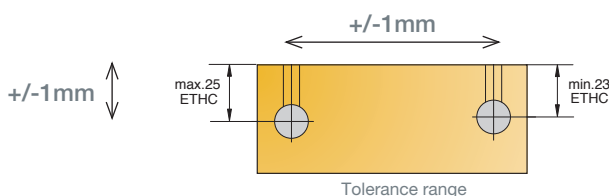

ETHC=Edge To Hole Center

## Quickfit dowels for factory insertion

Quickfit TL5, Quickfit TL4, and Quickfit TL2 are the only dowel solutions designed for factory pre-insertion

- Optimised packaging processes
- Reduced risk of quality issues and claims
- Ideal for the RTA market

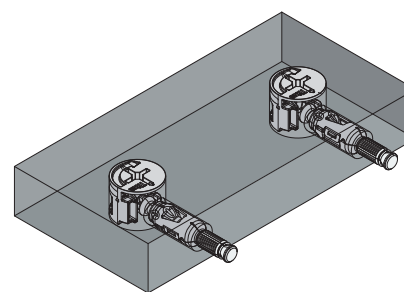

# System 5 Cams and Dowels

## Cam5000

### Highly resistant joint for strong cabinet construction

Reinforced cam evenly engages the hole and prevents cam tilting and cam bursting.

Increased joint resistance enables effective performance in wider tolerance range.



### Linear cam profile

Linear cam profile ensures:

- Smooth tightening action
- Greater dowel pull-up



### Cam retaining pips

Cam retaining pips ensures:

- The cam is held in position prior to assembly
- Secure cam positioning during transport and handling
- Accurate factory insertion



### 2 o'clock lock

Smooth and noticeable locking at the 2 o'clock position guarantees:

- always-right tightening for home assembly
- strong and rigid cabinet construction

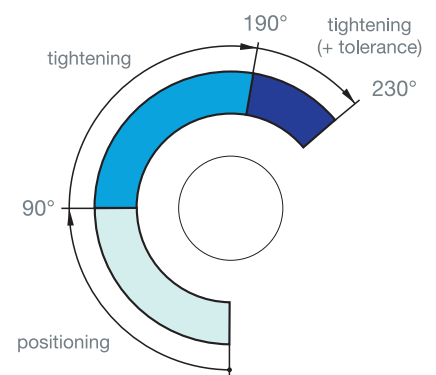

**Optimised cam profile**

Optimised cam profile ensures smooth and tight joint with no gap between panels.

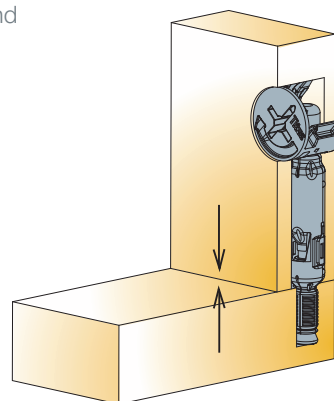

**Optimal performance with all Titus dowels**

Quickfit TL, Quickfit, Combi, end, double ended, angled and other screw-in dowels



# System 5 Cams and Dowels

## Quickfit Connectors

It is the fastest assembly system on the market. The Quickfit™ dowel may be inserted by hand, using only finger pressure. This eliminates the labour intensive process of screw-in assembly and the potential panel damage.

The Quickfit™ range of dowels has been extended to provide a complete family of fittings available in diameters of 5mm, 8mm, 10mm and lengths of 24mm and 34mm. These dowels are compatible with the range of Titus Ø15mm cams.

### Assembly

#### 1. Press the cam into face board

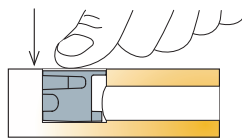

#### 2. Insert the dowel into side panel

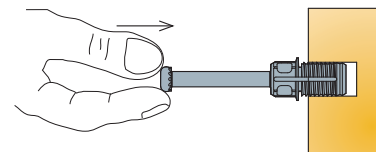

#### 3. Assemble the panels

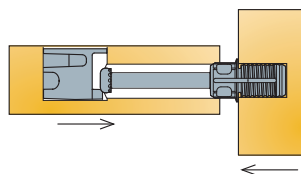

#### 4. Tighten the cam to lock dowel

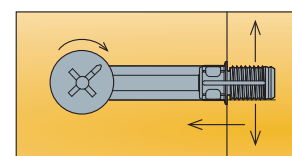
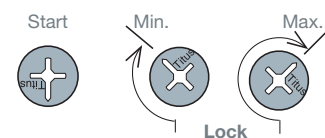

#### 5. Assembled panels

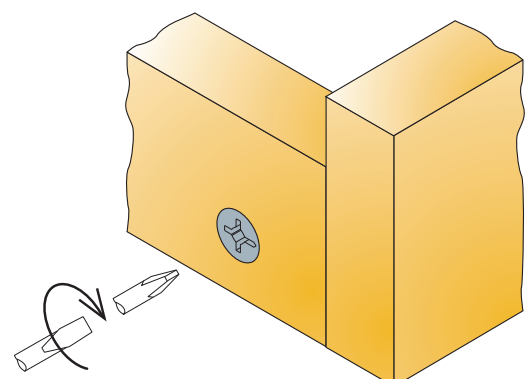

## Quickfit TL Connectors

Quickfit-TL™ dowel offers furniture manufacturers a fast assembly system providing high drilling tolerances. It has a built-in self-adjustment feature, which enables common drilling inaccuracies to be overcome.

For the self-assembly furniture consumer, Titus Quickfit-TL™ is the most consumer friendly fitting on the market. Apart from the benefit of fully tightened joints and easy locking into the same position, Quickfit-TL™ provides an exceptionally smooth action when tightened, requiring very little effort.

### Drilling tolerances

Marginal inconsistencies of drilling and the problems associated with the natural movement of wood panels, no longer present problems.

Quickfit-TL™ provides a tolerance of  $\pm 1$ mm on drilling operation while ensuring that the final result is a perfectly precise and aligned joint. No other assembly fittings system can offer such tolerances and still maintain a perfect joint.

### Assembly

#### 1. Press the cam into face board

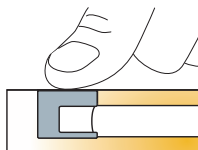

#### 2a. Either push dowel into edge hole or...

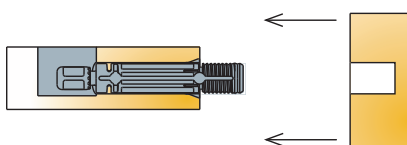

#### 2b. Insert the dowel into side panel

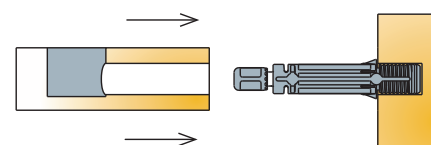

#### 3. Assemble the panels

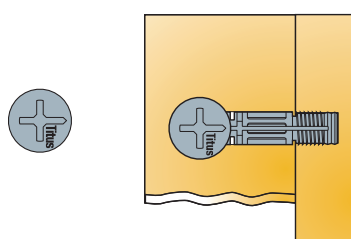

#### 4. Tighten cam to lock dowel

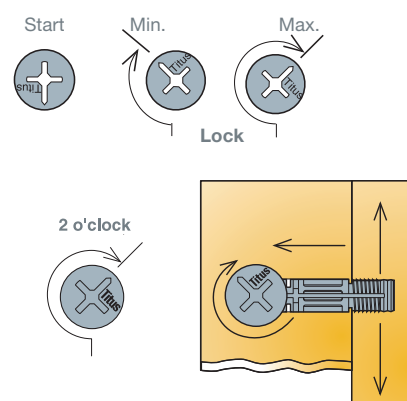

# System 5 Cams and Dowels

## Quickfit TL5 'Full Metal Jacket'

### Effective performance in multiple wooden materials

- Smooth and noticeable locking at the 2 o'clock position guarantees:
- tight joints
  - always-right tightening at home assembly
  - strong and rigid cabinet construction



### Strong and reliable joint

Expanding steel sleeve assures high resistance to torsion and pull-out.

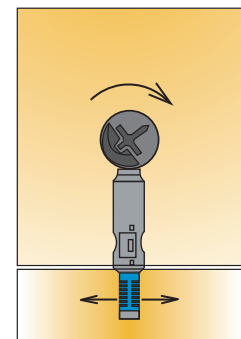

### High drilling tolerances

An extended dowel head design works as a positive stop against the cam and provides an ETHC tolerance of min. +/-1mm

Fully tightened joint assured even at marginal inconsistencies of drilling and problems associated with the natural movement of wood panels.

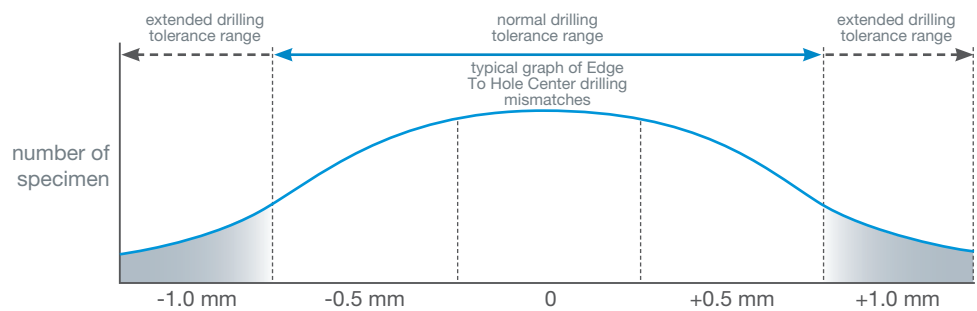
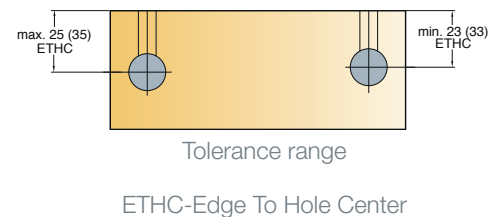

### Shape of dowel sleeve

- Acts as a positive stop when face inserted
- Ensures correct insertion depth



### Tool-free insertion for Ø5mm dowel holes

Quickfit TL5 reliably engages the 5mm dowel hole. It enables the usage of tool-less Quickfit dowel insertion technology across a wide range of applications.

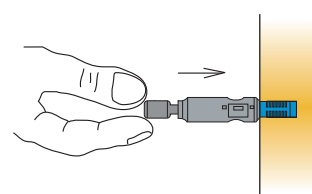

### 50% less time to assemble the cabinet at home

When edge inserted the dowel engages the cam and remains securely positioned until the boards are locked together.

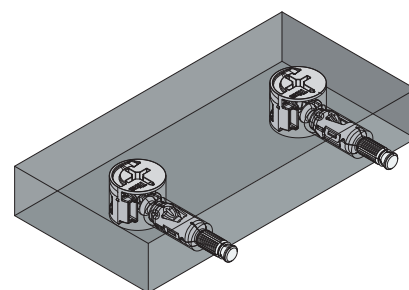

For maximum efficiency the insertion process can be automated using the Titus proprietary Lama FastFit machine.

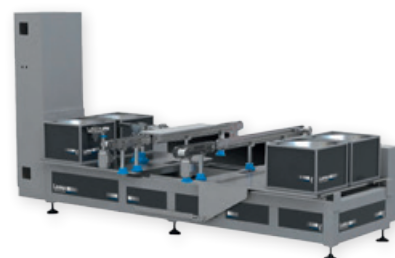

Fast and easy cabinet assembly at home.

**CAF** Quick & Easy

Consumer Assembly Friendliness

# System 5 Cams and Dowels

## Zinc+steel Combi Dowels

**Zinc+steel  
technology for  
optimal strength  
and performance**

The Combi dowel combines steel and a small amount of zinc to ensure high precision and dimensional accuracy, essential to provide furniture manufacturers with the broadest possible range of drilling tolerances.

**toroidal head form**

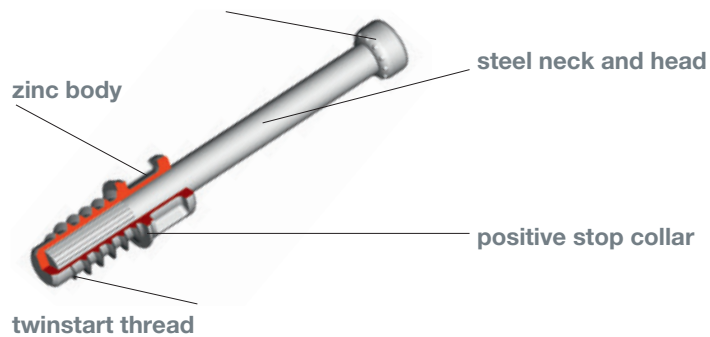

**The steel neck and head** provide better resistance to torsion and pull-out enabling a high performance joint

**Zinc body:**  
**Positive stop collar** ensures correct insertion depth  
**Twinstart** for faster and more stable insertion

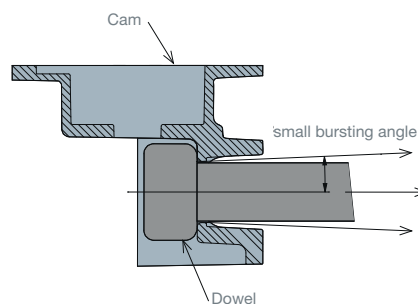

**The toroidal dowel head form** transfers the forces between cam and dowel more effectively resulting in a small cam bursting force.

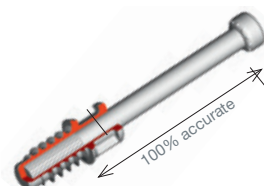

**100% dimensional accuracy  
assured**

# System 5 Cams and Dowels

## Quickfit TL5 'Full Metal Jacket'

- Drilling tolerances of +1/-1mm when edge inserted
- Expanding steel sleeve assures a strong joint, highly resistant to pull-out
- Tool-free insertion technology for Ø5mm holes in multiple wooden materials (chipboard, MDF, solid wood)
- For use with Cam5000

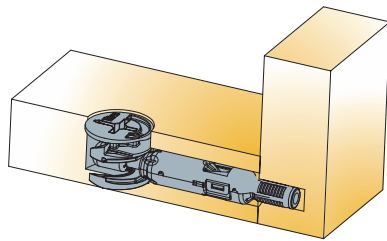

Technical and mounting details

Quickfit TL5 dowel

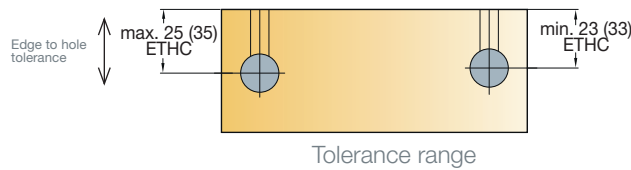
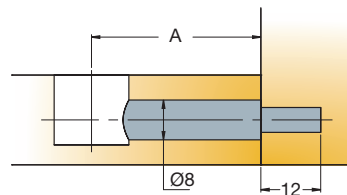
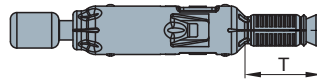

A	T	Item number	TeraBlack
Drilling distance	Thread length		
34	11.5	<b>09652</b> →	956
24	11.5	<b>09651</b> →	956

**i** Suitable for Cam5000 only

 1000 Pcs

Made of steel

# System 5

## Cams and Dowels

### Quickfit TL Dowels

- Available in Ø5mm and Ø8mm for panel-to-panel applications
- For use with all Cam3000 S and Cam5000 products
- 'Klix' locking feature provides a strong, vibration proof joint
- Highly tolerant in edge-inserted, TL4 also in face-inserted applications

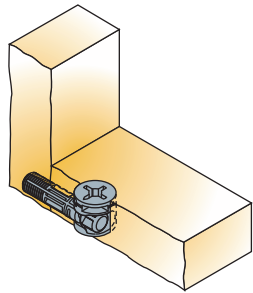

Technical and mounting details

#### Quickfit TL2

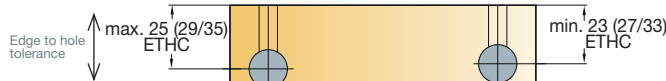
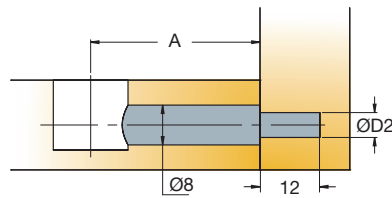
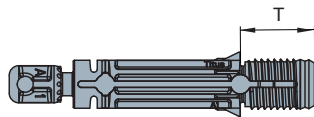

Tolerance range

2000 Pcs  
1000 Pcs (05474)

Made of zinc, plastic

#### Quickfit TL4

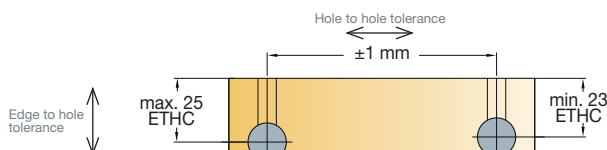
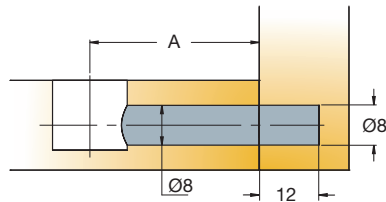
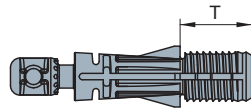

Tolerance range

3000 Pcs

Made of zinc, plastic

A	T	D2	Item number	Black	Dark grey
24	11.5	5	05453 →		880
34	11.5	5	05503 →		880
24	11.2	8	05366 →		880
28	11.2	8	05314 →		880
34	11.2	8	05474 →		880
24	11.2	8	05388 →	835	

# System 5

## Cams and Dowels

### Quickfit Dowels

- Available in Ø5mm, Ø8mm and Ø10mm for panel-to-panel applications
- For use with all Cam3000 S and Cam5000 products
- 'Klix' locking feature provides a strong, vibration proof joint
- Depth stop collar for accurate insertion

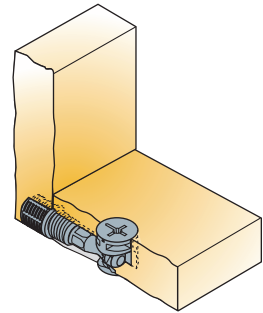

Technical and mounting details

Quickfit dowel  
Ø8mm



1000 Pcs (05556,05552)  
2000 Pcs (05563, 05554)

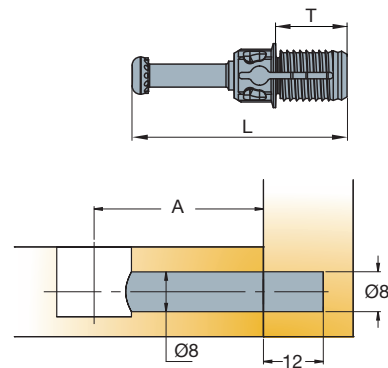

Made of zinc, plastic

Quickfit dowel  
Ø10mm



2000 Pcs

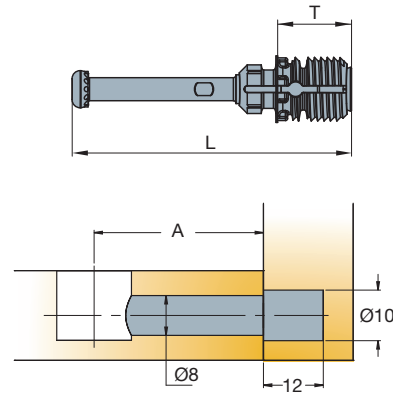

Made of zinc, plastic

Quickfit dowel  
For back-to-back application  
Ø10mm



1000 Pcs

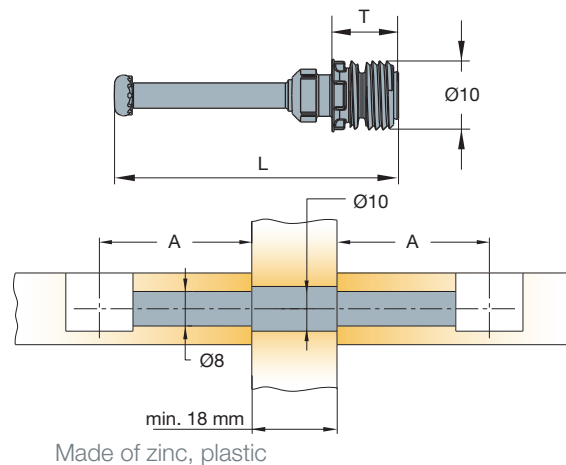

Made of zinc, plastic

A	T	L	Item number	Dark grey
Drilling distance	Thread length	Total length		
20	11.2	29.5	05556 →	880
24	11.2	33.5	05563 →	880
28	11.2	37.5	05552 →	880
34	11.2	43.5	05554 →	880
24	11.2	33	05052 →	880
34	11.2	43	05050 →	880
24	9	30.5	05270 →	880
34	9	40.5	05147 →	880

# System 5

## Cams and Dowels

### Quickfit P2F Dowels

- The only product to enable standard panel drilling and connection of panel and hollow profile
- Available in Ø8mm for panel-to-hollow metal profile applications
- For use with all Cam3000 S and Cam5000 products
- 'Klix' locking feature provides a strong, vibration proof joint

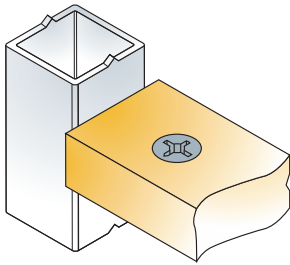

Technical and mounting details

Quickfit P2F

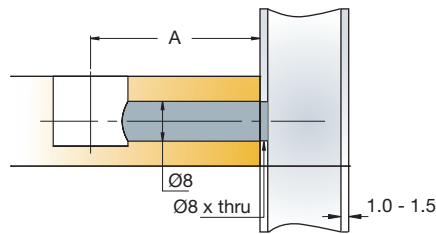
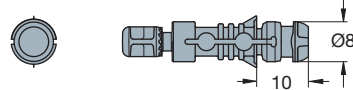

A

Drilling distance

Item number

Black

24

05414 →

835

2000 Pcs

Made of zinc, plastic

# System 5

## Cams and Dowels

### Combi Dowel

- High quality zinc-steel dowel with greater resistance to torsion and pull-out
- For use with all Cam3000 S and Cam5000 products
- 'Klix' locking feature provides a strong, vibration proof joint
- Twinstart thread for faster and reliable insertion

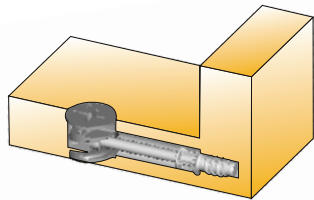

Technical and mounting details

#### Combi dowel

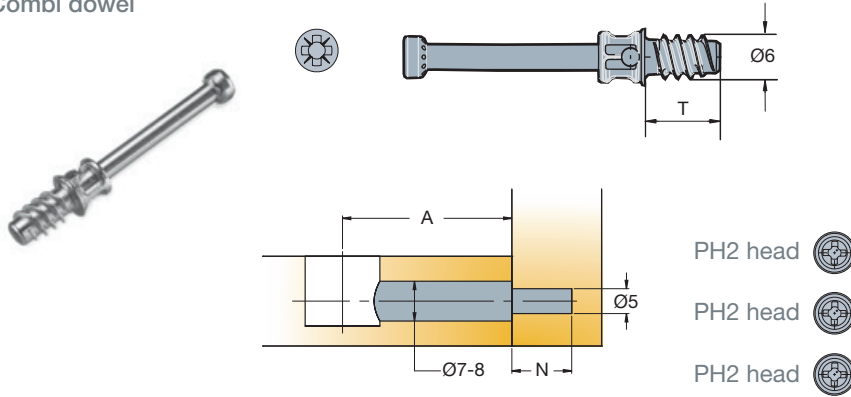

1000 Pcs  
\*2000 Pcs

Made of steel and zinc

#### Combi dowel M6

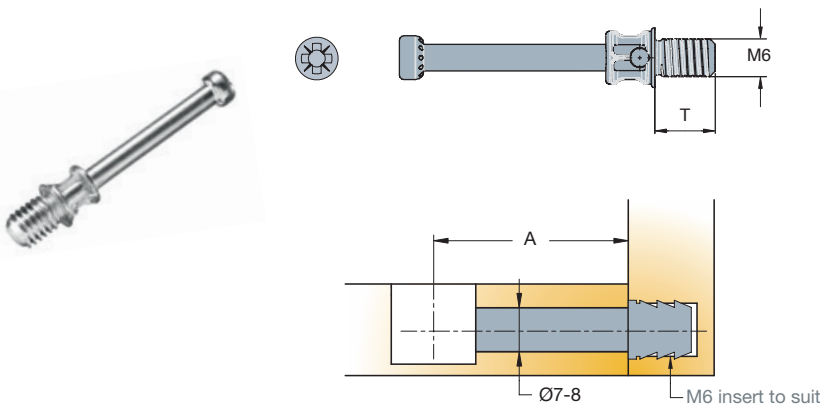

1000 Pcs

Made of steel and zinc



→ see page 1.70



→ see page 1.70



A	N	T	Item number	Zinc
Drilling distance	Drilling depth	Thread length		
34	12	11	09435 →	885
28	10	9.5	09588 →	885
24	12	11	09443 →	885
24	9	8.5	09583 →	885
34	12	11	*09424 →	885
24	12	11	*09423 →	885
34	9	8.5	*09456 →	885
<i>*American market only</i>				
34		8	09592 →	885
34		10.5	09594 →	885

# System 5

## Cams and Dowels

### Combi Dowel

- High quality zinc-steel dowel with greater resistance to torsion and pull-out
- For use with all Cam3000 S and Cam5000 products
- 'Klix' locking feature provides a strong, vibration proof joint
- Twinstart thread for faster and reliable insertion

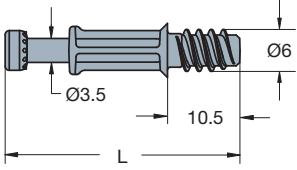
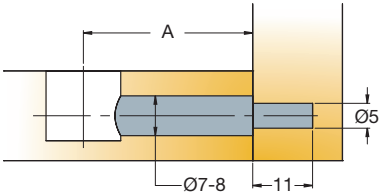
		L	A		
Technical and mounting details		Total length	Drilling distance	Item number	Zinc
Combi dowel Full body	PZ2 head 	34.5	24	09597 →	885
  					

 1000 Pcs

Made of steel and zinc

 Inserts  
Made of plastic

→ see page 1.70

# System 5

## Cams and Dowels

### Combi-P Dowel

- Full body assures a strong joint highly resistant to torsion and pull-out, even in low density chipboard
- Accurate insertion with positive stop

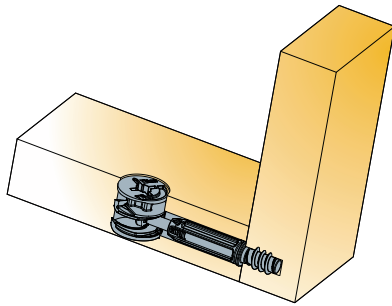

Technical and mounting details

Combi-P Dowel

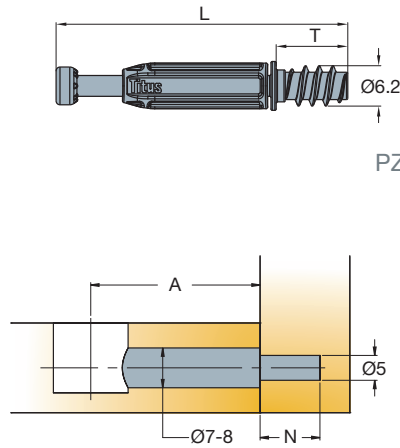

PH2 head 

PZ2 head 

A	N	T	L	Item number	Zinc plated
Drilling distance	Drilling depth	Thread length	Total Length		
34	12	11	44.8	05072 →	883
24	12	11	34.8	05073 →	883
24	9	8.5	32.3	05087 →	883
34	12	11	44.8	05078 →	883
24	12	11	34.8	05079 →	883

# System 5

## Cams and Dowels

### Double-ended Dowel

- Available in Ø7mm
- For use with all Cam3000 S and Cam5000
- No circlip for increased tolerance
- Available in a variety of lengths to suit most panel-to-panel applications

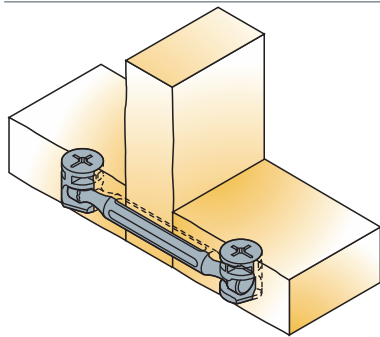

Technical and mounting details

#### Dowel without circlip

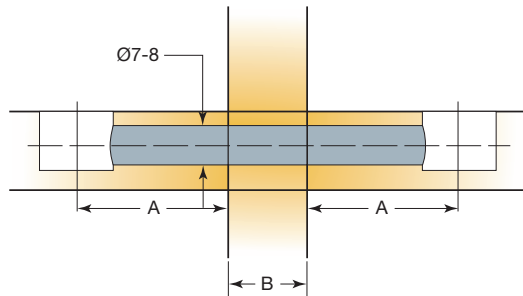
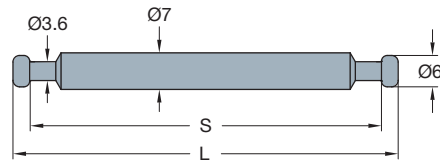

- 250 Pcs (05753)
- 500 Pcs (05857)
- 1000 Pcs (05929)

Made of steel

#### Dowel with circlip

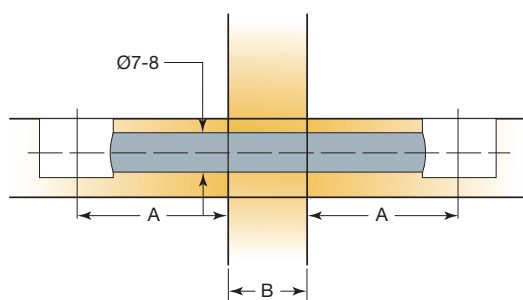
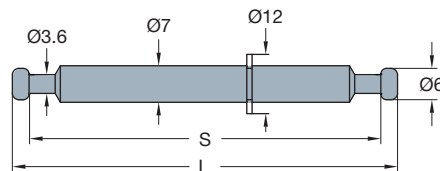

- 250 Pcs
- 500 Pcs (05775, 05774)

Made of steel

S	L	A	B	Item number	Zinc plated
Length	Total length	Drilling distance	Panel thickness		
41	47.4	24	0*	05929 →	883
61	67.4	34	0*	05757 →	883
77	83.4	34	16	05858 →	883
79	85.4	34	18	05859 →	883
80	86.4	34	19	05753 →	883
56	62.4	24	15	05592 →	883
57	63.4	24	16	05857 →	883
59	65.4	24	18	05380 →	883
60	66.4	24	19	05778 →	883
*B=0 → no panel required					
77	83.4	34	16	05752 →	883
79	85.4	34	18	05772 →	883
80	86.4	34	19	05751 →	883
57	63.4	24	16	05775 →	883
60	66.4	24	19	05774 →	883

# System 5

## Cams and Dowels

### Angled Dowels

- For applications requiring angled joints
- For use with all Cam3000 S and Cam5000
- Adjustable angle from 90° to 180°

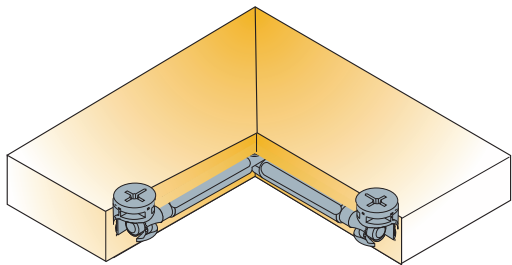

Technical and mounting details

Item number

Zinc plated

Cabinet Connectors

Angled dowel  
180° fixed

05860 →

883

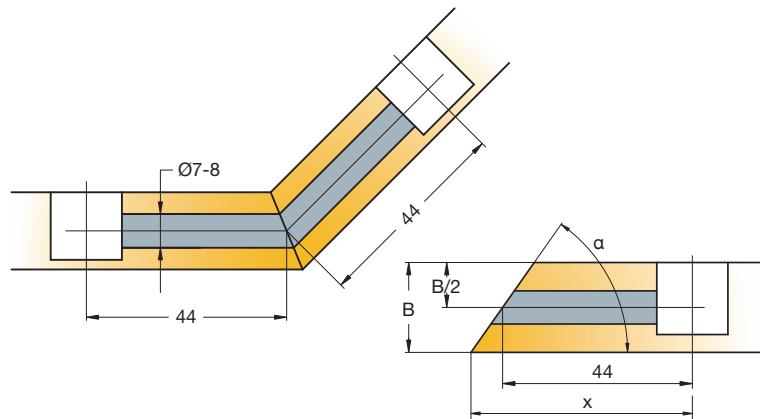

Distance x in mm

Q	20°	25°	30°	35°	40°	45°	50°	55°	60°	65°	67,5°	70°	75°	80°	85°		
13	61.9	57.9	55.3	53.5	51.7	50.5	49.5	48.6	47.8	47	46.7	46.4	45.7	45.1	44.6		
15	64.6	60.1	57	54.7	52.9	51.5	50.3	49.3	48.3	47.5	47.1	46.7	46	45.3	44.7		
16	66	61.2	57.9	55.4	53.5	52	50.7	49.6	48.6	47.7	47.3	46.9	46.1	45.4	44.7		
B	18	68.8	63.3	59.6	56.9	54.7	53	51.6	50.3	49.2	48.2	47.7	47.3	46.4	45.6	44.8	
	19	70.1	64.4	60.5	57.6	55.3	53.5	52	50.7	49.5	48.4	47.9	47.5	46.5	45.7	44.8	
	22	74.2	67.6	63.1	59.7	57.1	55	53.2	51.7	50.4	49.1	48.6	48	46.9	45.9	45	
	23	75.6	68.7	63.9	60.4	57.7	55.5	53.6	52.1	50.6	49.4	48.8	48.2	47.1	46	45	x

250 Pcs

Made of steel

Angled dowel  
90° fixed

05282 →

883

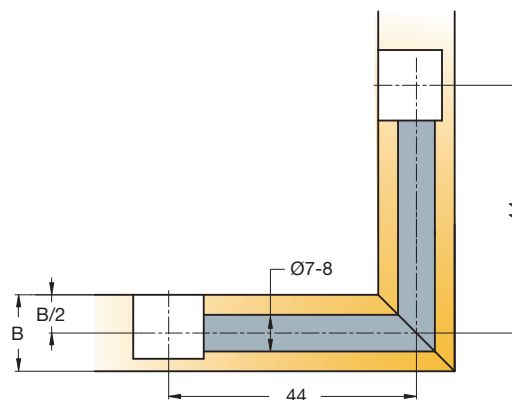

1000 Pcs



Made of steel

# System 5

## Cams and Dowels

### End Dowels

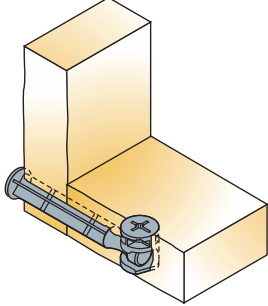
- Available in a variety of head and length combinations to suit most end panel applications
- For use with all Cam3000 S and Cam5000
- 'Klix' locking feature provides a strong, vibration proof joint
- Both 'mushroom' and countersunk headed versions available

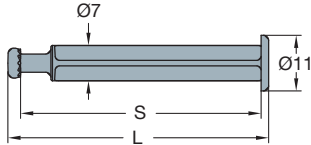
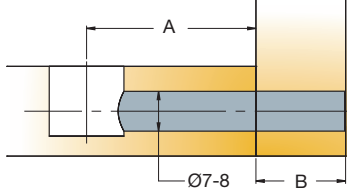
Technical and mounting details		A	B	S	L	Item number	Zinc
		Drilling distance	Panel thickness	Length	Total length		
<p>Mushroom dowel</p>    	24	16	36.5	40.5	<b>05608</b> →	885	
	24	19	39.5	43.5	<b>05609</b> →	885	
	34	16	46.5	50.5	<b>05610</b> →	885	
	34	19	49.5	53.5	<b>05611</b> →	885	
	24	12	32.6	37.3	<b>05010</b> →	885	

500 Pcs (05610, 05611)  
1000 Pcs (05608, 05609)

Made of zinc

# System 5

## Cams and Dowels

### Cam5000 Ø15mm

- Improved central shape for highly resistant joint
- For use with all Titus dowels
- 'Klix' locking feature provides a strong, vibration proof joint
- Cam retaining pips ensure that a cam is held in panel position prior to assembly

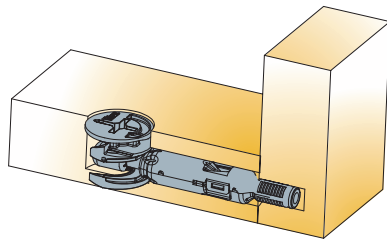

Technical and mounting details

B	D	e	h	Item number	Zinc	Noir
Panel thickness	Drilling depth	Drilling for dowel	Cam height			
12/13	10.5	6 min	9.9	<b>09695</b> →	885	959
15/16	12.5	7.5-8	11.9	<b>09690</b> →	885	959

Cam5000 cross drive

PZ2 drive

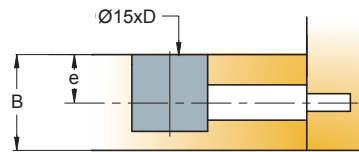
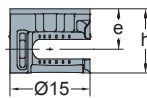

1000 Pcs

Made of zinc

Cam5000 hexagonal drive

Combined drive with HEX

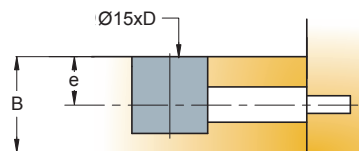
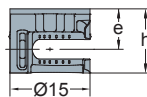

15/16	12.5	7.5-8	11.9	<b>09699</b> →	885	
18/19	14	9-9.5	13.2	<b>09692</b> →	885	959
22/23	16	11-11.5	15.2	<b>09332</b> →	885	
25/26	18	12.5-13	16.7	<b>09335</b> →	885	
28/29	19.5	14-14.5	18.2	<b>09336</b> →	885	959

Noir available upon request

1000 Pcs  
500 Pcs (9335, 9336)

Made of zinc

Cover caps for Ø15 cams  
Made of plastic

→ see page 1.44

# System 5

## Cams and Dowels

### Cam5000 Ø15mm

- Improved central shape for highly resistant joint
- For use with all Titus dowels
- 'Klix' locking feature provides a strong, vibration proof joint
- Cam retaining pips ensure that a cam is held in panel position prior to assembly

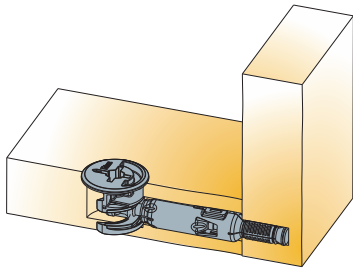

Technical and mounting details

Cam5000 headed cross drive

PZ2 drive 

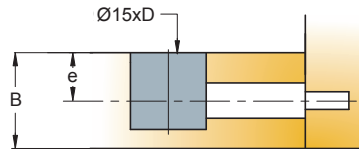
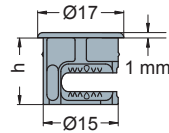



 1000 Pcs

Made of zinc

Cam5000 headed hexagonal drive

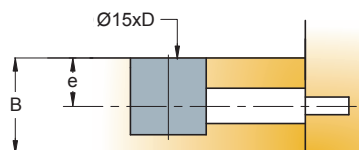
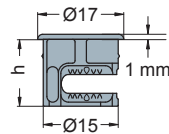
Combined drive with HEX 



 1000 Pcs  
500 Pcs (9337)

Made of zinc

B	D	e	h	Item number	Nickel	Zinc	Noir
Panel thickness	Drilling depth	Drilling for dowel	Cam height				
12	10min	6	9.9	<b>09330</b> →		885	
<i>Noir available upon request</i>							

16	13	8	12.4	<b>09333</b> →	847	885	
19	14.5	9.5	13.9	<b>09334</b> →	847	885	
29	19.5	14.5	18.9	<b>09337</b> →		885	







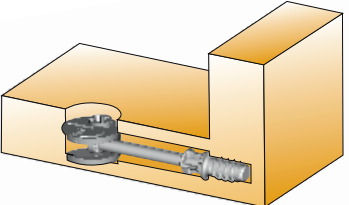

<i>Noir available upon request</i>							
------------------------------------	--	--	--	--	--	--	--

# System 5

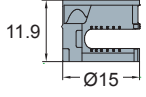
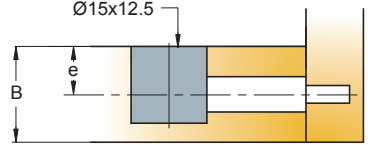
## Cams and Dowels

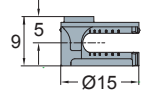
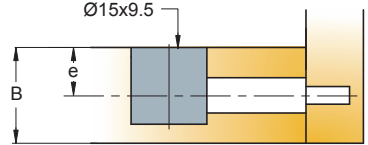
### Cam3000S Ø15mm

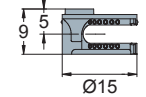
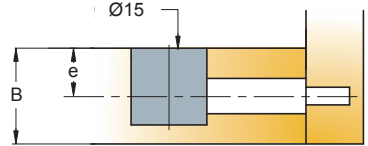
- Innovative design offers optimal performance with maximum cost effectiveness
- For use with Combi dowels, forged steel dowels and Quickfit dowels
- 'Klix' locking feature provides a strong, vibration proof joint
- Cam-retaining pins ensure that a cam is held in panel position prior to assembly

 Technical and mounting details		B	e	Item number	Zinc	Zinc corrosil
		Panel thickness	Drilling for dowel			
<b>Cam3000 S/15</b>  1000 Pcs Made of zinc	  PZ2 drive 	15/16	7.5/8	<b>09491</b> →	885	897
<b>Cam3000 S/12</b>  2000 Pcs Made of zinc	  PZ2 drive 	12 min	min 6	<b>*09406</b> →	885	897
<i>* European market only</i>						
<b>Cam3000 S/12</b>  1000 Pcs Made of zinc	  Philips PH2 drive 	12 min	min 6	<b>*09631</b> →	885	
<i>* American market only</i>						

 Cover caps 09630  
Made of plastic

# System 5

## Cams and Dowels

### Cam2000S Ø12mm

- For all Titus screw-in dowels
- Available in a variety of head, drive recess and board thickness versions to suit most applications
- Particularly suited to drawer front attachment applications
- 'Klix' locking feature provides a strong, vibration proof joint

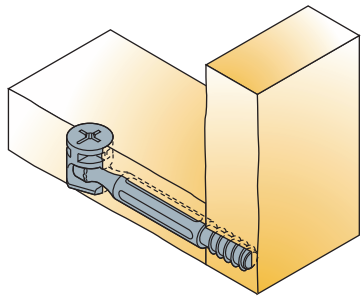

Technical and mounting details

Cam2000  
Ø12mm

PZ2 drive 

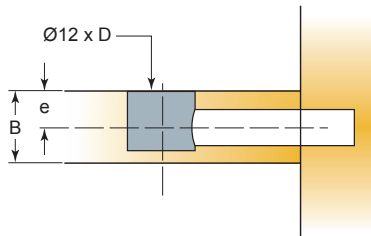
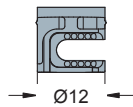

 2000 Pcs

Made of zinc

Cam2000  
Ø12mm headed

PZ2 drive 

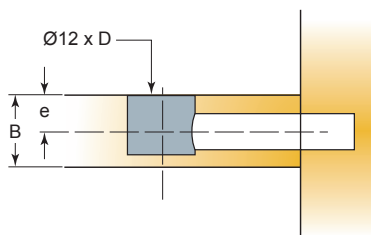
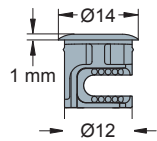

 1000 Pcs  
2000 Pcs (05576)

Made of zinc

B	D	e	Item number	Black painting plate	Nickel plated	Zinc	Corrosil zinc
12/13	10 min	6-6.5	<b>05575</b> →	838	847	885	897
15/16	12	7.5-8	<b>05578</b> →			885	
18/19	13 min	9-9.5	<b>05580</b> →			885	

Other finishes on request

**i** Not suitable for Quickfit TL5 dowels







12	9.2 min	5.25	<b>05574</b> →	838	847	885	897
12	10 min	6	<b>05576</b> →			885	
16	12.5	8	<b>05579</b> →			885	

Other finishes on request

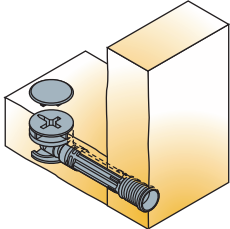
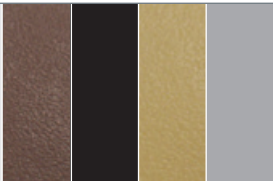
**i** Not suitable for Quickfit dowels

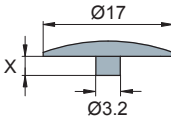
# System 5 Cover Caps

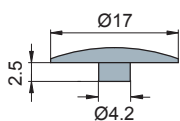
- Available in a variety of colours
- For use with both pozi and hex cam drive features
- Suitable for use with various diameter cams
- Both domed and flat versions available

 Technical and mounting details		X					
			Pin length	Item number	Dark brown	Black	Light brown
Cover cap Ø17mm 		3.3	<b>*01029</b> →	834	835	867	882
		2.5	<b>277-4355</b> →	370	390	330	380
 1000 Pcs <span style="margin-left: 100px;">Made of plastic</span>		*American market only Other colours on request  Suitable for cams with Pozi 2 recess					
Cover cap Ø17mm 			<b>277-4225</b> →	370	390	330	380
		Other colours on request  Suitable for cams with Hex recess					
 1000 Pcs <span style="margin-left: 100px;">Made of plastic</span>							

# System 6

## Quickfit-Expando

### Connectors

#### System Features

A face boring connector family for 32mm system drilling with full range of panel and application variants for all cabinet manufacturing applications.

- Minimum drilling requirements
- Linear cam design for constant tightening loads when driving
- Angledriv feature on cam for maximum driving comfort
- Interchangeable pins for wood, plastic and steel applications
- Pins with twinstart drive for fast insertion
- Interchangeable Quickfit pin fastenings available
- Tool-less fastening capable versions
- Back-to-back fastenings for common vertical panel fixing of shelves

System 6 consists of a range of 20mm diameter housing, Quickfit™ and conventional dowels, end dowels and double ended dowels.

Housings are made from high grade plastic or zinc, with zinc cams.

Wedgefix-6 connector is a special fastener without cam, simply to snap onto a pre-inserted dowel.

#### Applications

Titus System 6 is ideal for use in high volume production of case goods, closet and garage storage systems. Because no

edge boring is required, it is an excellent choice for manufacturing environments with limited drilling capacity.

#### Side-entry Drop-on

**Side-entry** insertion of shelf panel: from the side or from the top

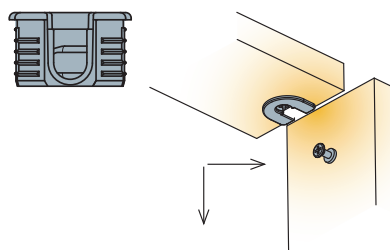

**Drop-on** insertion of shelf panel: only from the top  
Using drop-on connections allows for one-man installation

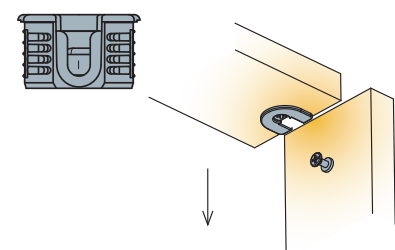

**Outrigger/  
Non outrigger**

Outrigger

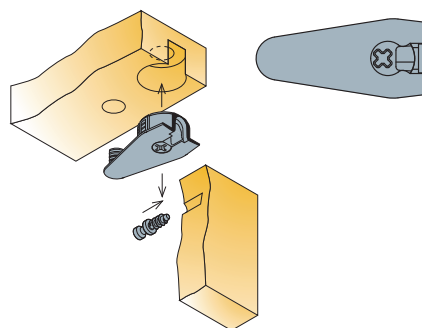

Non outrigger

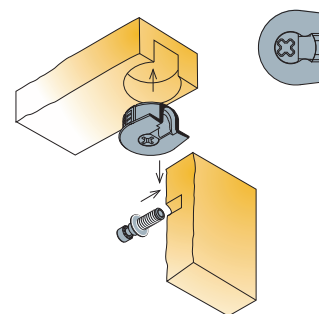

**Expando function**

Expanding housings and dowels provide a tight joint.

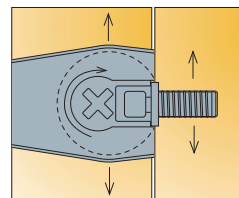
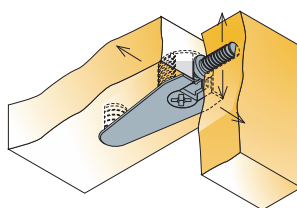

**Assembly**

1. Press the housing into face board

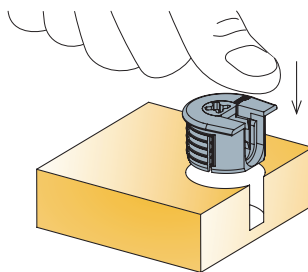

2. Press the dowel into side panel

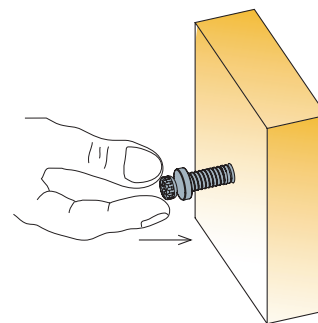

3. Assemble the panels

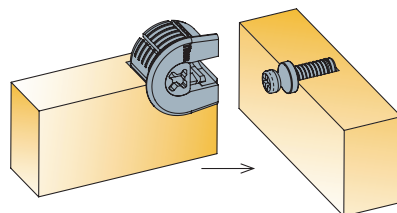



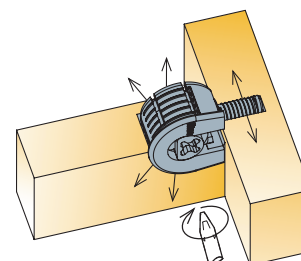



4. Tighten the joint

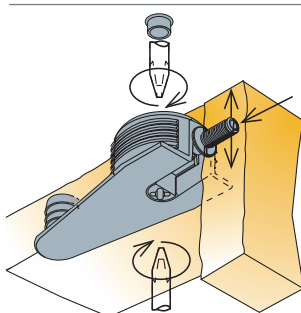

# System 6 Quickfit-Expando Expanding Dowels

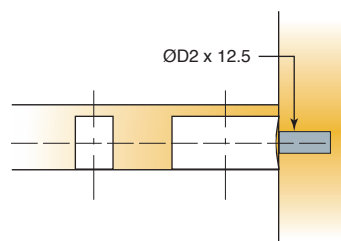

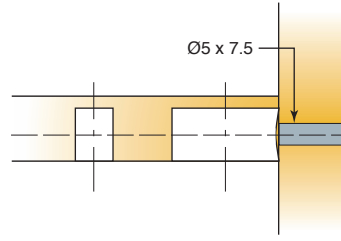





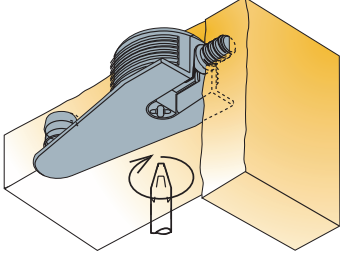

**i** Not suitable for System 6.2

- Available in Ø5mm, Ø8mm for panel-to-panel, and back-to-back applications
- For applications with all Titus Ø20 and Sys 6 housings
- 'Klix' locking feature provides a strong, vibration proof connection
- Depth stop collar for accurate insertion

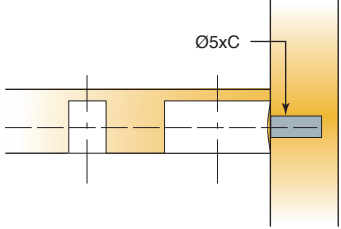
Technical and mounting details		D2		Dark grey
		Drilling diameter for dowel thread	Item number	
<p>Dowel</p> 	<p>Technical and mounting details</p>	5	<b>06408</b> →	880
		8	<b>06410</b> →	880
 <p>D2= Ø5mm</p>	 <p>Ø2 x 12.5</p>			
 <p>D2= Ø8mm</p>				
 <p>Dowel Ø5 x 7.5 back-to-back applications</p>	 <p>Ø5 x 7.5</p>	5	<b>06479</b> →	880
 <p>5000 Pcs</p>	<p>Made of zinc, plastic</p>			

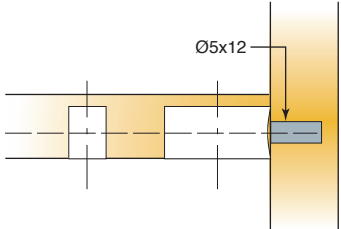
# System 6 Quickfit-Expando Dowels

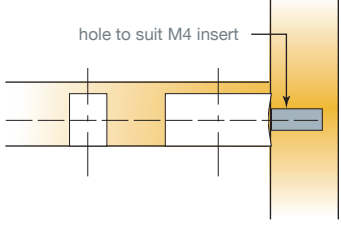
- Available in various Ø3mm and/or Ø5mm thread forms for screw-in, knock-in and/or 'spiked' hole applications
- For applications with all Titus Ø20mm and Sys 6 housings
- 'Klix' locking feature provides a strong, vibration proof connection
- Dowels feature an integral skirt which acts as a positive stop during insertion

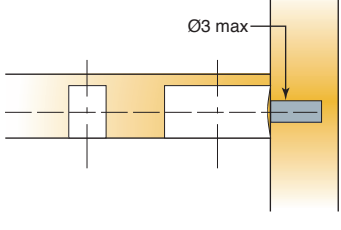
 Technical and mounting details		C	Drilling depth for dowel thread	Item number		
					Zamak	Zinc plated
<b>Dowel Ø5</b>        2000 Pcs Made of zinc or steel	9	06401 →	885			
	8	06402 →	885	883		
	11.5	06406 →	885	883		
<b>Dowel Ø5 x 11 knock-in</b>        2000 Pcs Made of zinc		06403 →	885			
<b>Dowel M4 x 7</b>        4500 Pcs Made of steel		06405 →		883		
<b>Dowel Ø3 x 11.5</b>        12500 Pcs Made of steel		06495 →		883		



 Inserts  
 Made of plastic  
 → see page 1.70

# System 6

## Quickfit-Expando

### Double-ended Dowels

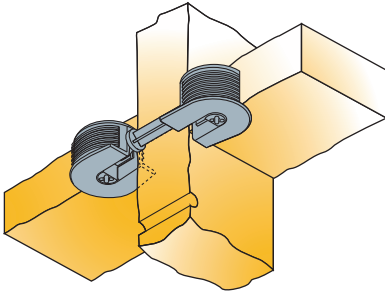
- For 16mm, 18mm and 19mm board
- For applications with all Titus Ø20mm and Sys 6 housings
- 'Klix' locking feature provides a strong, vibration proof connection



Technical and mounting details

Double-ended dowel

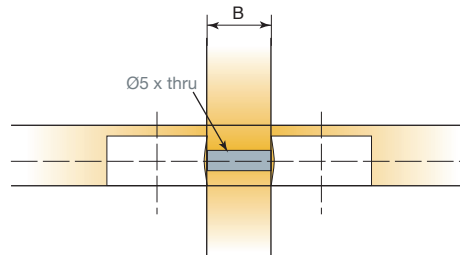
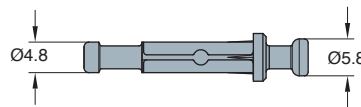

B	Item number	Zinc
Panel thickness		
16	06414 →	885
18	06413 →	885
19	06416 →	885

2500 Pcs

Made of zinc

# System 6 Quickfit-Expando End Dowels

- For 16mm, 18mm and 19mm board
- For applications with all Titus Ø20mm and Sys 6 housings
- 'Klix' locking feature provides a strong, vibration proof connection

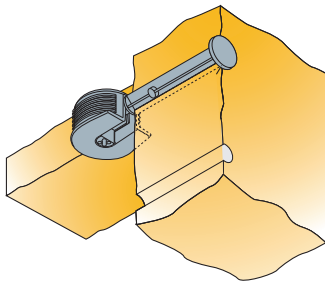

Technical and mounting details

End dowel

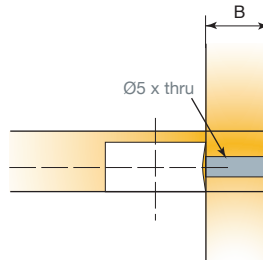
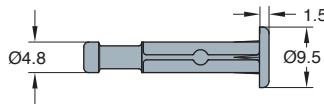

B	Item number	Zinc
Panel thickness		
16	06412 →	885
18	06411 →	885
19	06415 →	885

2000 Pcs  
1000 Pcs (06411)

Made of zinc







# System 6

## Quickfit-Expando

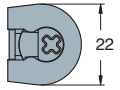
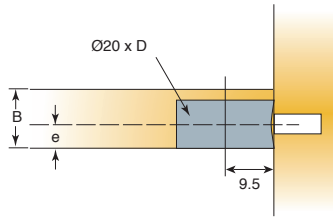
### 20mm Expanding Housing

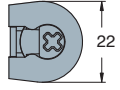
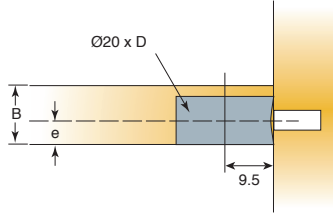
### Non-outrigger

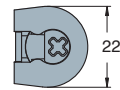
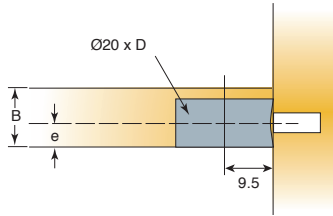
- Available in 15mm/16mm and 18mm/19mm versions for drop-on and/or side-entry applications
- Available in all-metal or plastic/metal options
- 'Klix' locking feature provides a strong vibration proof connection
- Compatible with all Sys 6 screw-in and Quickfit dowels

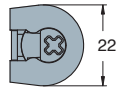
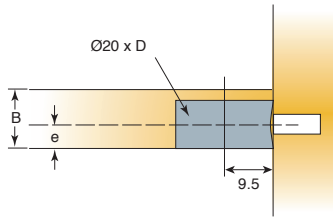
Technical and mounting details				e	B	D	Item number	Dark brown plastic	Nickel plated	Silver plastic	White plastic
					Panel thickness	Drilling depth					
<b>Side-entry</b>    500 Pcs Made of zinc	7.75	15/16	12.5	<b>06451</b> →		847					
	9.25	18/19	14	<b>06453</b> →		847					
<b>Side-entry</b>    2500 Pcs Made of plastic	7.75	15/16	12.5	<b>06435</b> →	831		861	877			
	9.25	18/19	14	<b>06437</b> →	831		861	877			
<i>Other colours on request</i>											
<b>Drop-on</b>    500 Pcs Made of zinc	7.75	15/16	12.5	<b>06447</b> →		847					
	9.25	18/19	14	<b>06449</b> →		847					
<b>Drop-on</b>    2500 Pcs Made of plastic	7.75	15/16	12.5	<b>06431</b> →	831		861	877			
	9.25	18/19	14	<b>06433</b> →	831		861	877			
<i>Other colours on request</i>											

# System 6

## Quickfit-Expando

### 20mm Expanding Housing

### Outrigger

- Available in 15mm/16mm and 18mm/19mm versions for drop-on and/or side-entry applications
- Available in all-metal or plastic/metal options
- 'Klix' locking feature provides a strong vibration proof connection
- Compatible with all Sys 6 screw-in and Quickfit dowels

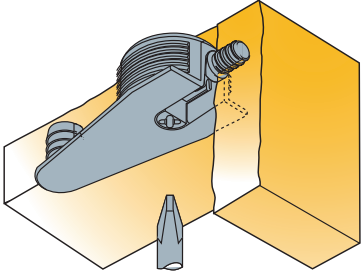
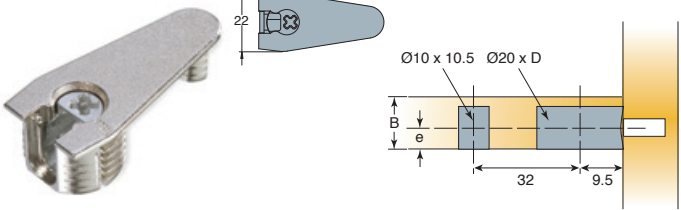
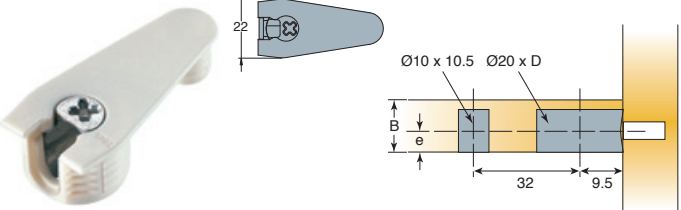
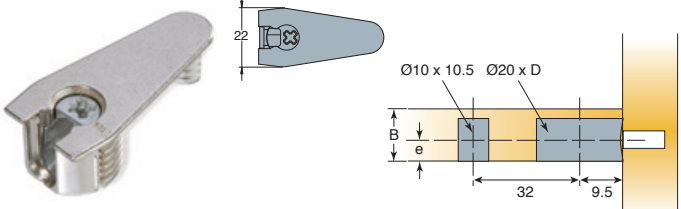
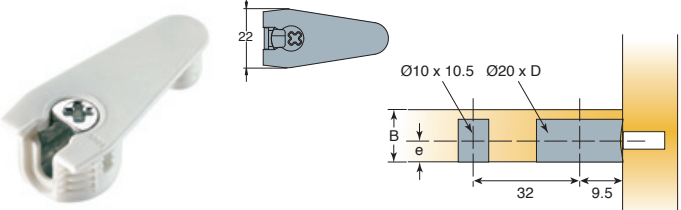
Technical and mounting details		e	B	D	Item number	Dark brown plastic	Black plastic	Nickel plated	White plastic
 <p>Technical and mounting details</p>			Panel thickness	Drilling depth					
Side-entry	 <p>500 Pcs Made of zinc</p>	7.75	15/16	12.5	<b>06459</b> →			847	
		9.25	18/19	14	<b>06461</b> →			847	
Side-entry	 <p>1250 Pcs Made of plastic</p>	7.75	15/16	12.5	<b>06443</b> →				877
		9.25	18/19	14	<b>06445</b> →	831	835		877
		9.25	18/19	14	<b>*06395</b> →		835		877
		Other colours on request *American market only							
Drop-on	 <p>500 Pcs Made of zinc</p>	7.75	15/16	12.5	<b>06455</b> →				847
		9.25	18/19	14	<b>06457</b> →				847
Drop-on	 <p>1250 Pcs Made of plastic</p>	7.75	15/16	12.5	<b>06439</b> →		835		877
		9.25	18/19	14	<b>06441</b> →	831	835		877
		9.25	18/19	14	<b>*06397</b> →		835		877
		Other colours on request *American market only							

# System 6

## Quickfit-Expando

### Expanding Wedgefix Housing (no Inner Cam)

- Available in 12mm, 15mm/16mm and/or 18mm/19mm versions for Sys 6 screw-in and Quickfit dowel applications
- Available in a variety of plastic colours
- Wedgefix housing allows easy customer hand-assembly or factory automated insertion
- When used with Sys 6 Quickfit dowels this provides a true tool-less fastening system

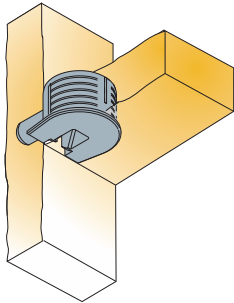

Technical and mounting details

For use with screw-in dowels

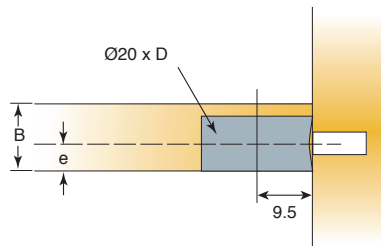
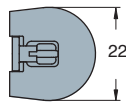

2500 Pcs

Made of plastic

For use with Quickfit dowels

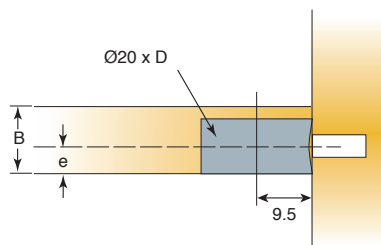
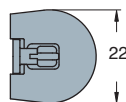

2500 Pcs

Made of plastic

e	B	D	Item number	White	Black	Dark brown	Silver
6	12	10	<b>06470</b> →	877			861
7.75	15/16	12.5	<b>06473</b> →	877	835	831	861
9.25	18/19	14	<b>06465</b> →	877	835	831	861
11	22	16	<b>06464</b> →				861
<i>Other colours on request</i>							
7.75	15/16	12.5	<b>06471</b> →	877	835	831	861
9.25	18/19	14	<b>06472</b> →	877	835	831	861
<i>Other colours on request</i>							

# System 6

## 20mm Knock-in Housing

### Non-outrigger

- Available in 15mm/16mm and 18mm/19mm versions for drop-on and/or side-entry applications
- Available in plastic-metal options
- 'Klix' locking feature provides a strong vibration proof connection
- Compatible with all Sys 6 screw-in and Quickfit dowels

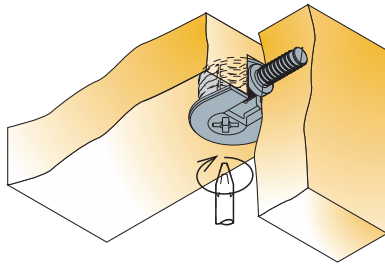

Technical and mounting details

#### Side-entry

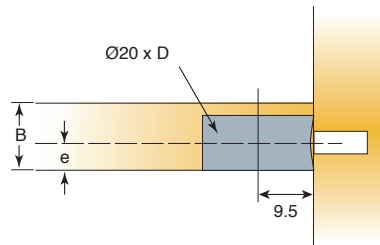
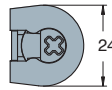

2500 Pcs

Made of plastic

#### Drop-on

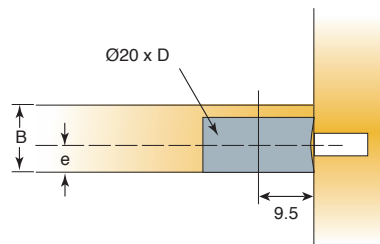
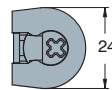

2500 Pcs

Made of plastic

Cover cap 06936  
Made of steel

e	B	D	Item number	Silver plastic	White plastic
7.75	15/16	12.5	<b>06381</b> →	861	877
9.25	18/19	14	<b>06385</b> →	861	877
<i>Product available on American and Asian market only</i>					
<i>Other colours on request</i>					

7.75	15/16	12.5	<b>06383</b> →	861	877
9.25	18/19	14	<b>06387</b> →	861	877
<i>Product available on American and Asian market only</i>					
<i>Other colours on request</i>					

# System 6

## Flush 20mm Knock-in Housing Non-outrigger

**i** For use with dedicated drill bit only.  
See below.

- A face-boring connector with the flush housing permits easy flat-pack transportation without panel damage
- Available for 19mm board thickness for drop-on and/or side-entry applications
- 'Klix' locking feature provides a strong vibration proof connection
- Compatible with all Sys6 screw-in and Quickfit dowels

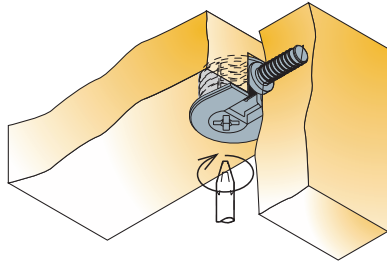

Technical and mounting details

e	B	D	Item number	White plastic
	Panel thickness	Drilling depth		

### Side-entry

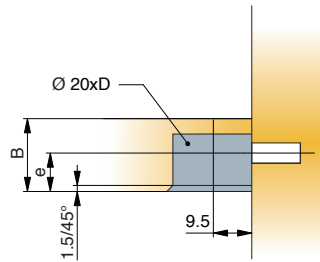
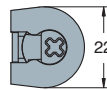

9.5	19	14.2	*06343 →	877
-----	----	------	----------	-----

\*American market only

1000 Pcs

Housing made of plastic, cam made of zinc

### Drop-on

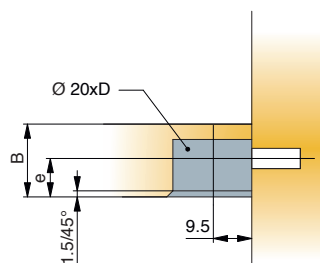
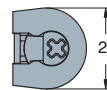

9.5	19	14.2	*06348 →	877
-----	----	------	----------	-----

\*American market only

1000 Pcs

Housing made of plastic, cam made of zinc

### Drill bit for Flush 20mm Knock-in housing

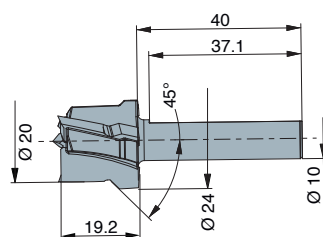

right handed

left handed

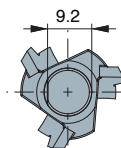

		00435	
		00436	

\*American market only

1 Pcs

Made of carbon steel



# System 6.2

## Quickfit-Expando

### Connectors

#### System Features

A face boring connector family for 32mm system drilling with full range of panel and application variants for all cabinet manufacturing applications.

- Minimum drilling requirements
- Anti-rotation ribs prevent rotation during tightening for reliable product performance
- Angledriv feature on cam for maximum driving comfort
- Interchangeable pins for wood, plastic and steel applications
- Pins with twinstart drive for fast insertion
- Interchangeable Quickfit pin fastenings available
- Tool-less fastening capable versions
- Back-to-back fastenings for common vertical panel fixing of shelves

System 6.2 consists of a range of 20mm diameter housing, Quickfit™ and conventional dowels, end dowels and double ended dowels.

Housings are made from high grade plastic with zinc cams.

Wedgex connector is a shelf fastener without cam, simply to snap onto a pre-inserted dowel.

#### Applications

Titus System 6.2 is ideal for use in high volume modular cabinet production: closets, wardrobes, garage storage systems, and shelving units.

Because no edge boring is required, it is an excellent choice for manufacturing environments with limited drilling capacity.

#### Side-entry Drop-on

**Side-entry** insertion of shelf panel: from the side or from the top

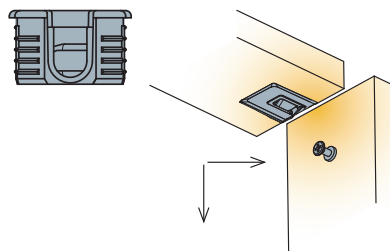

**Drop-on** insertion of shelf panel: only from the top  
Using drop-on connections allows for one-man installation

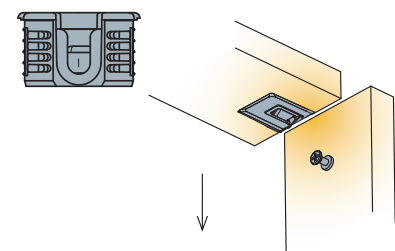

#### Efficient square design

Square shape guides the eye to easy insertion parallel to the board panel and allows a larger surface of the product

to rest on the panel when tightened for optimal positioning and ease at tightening.

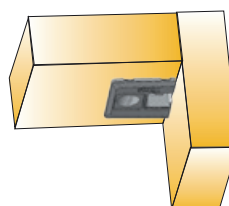

### Ribs on housing prevent rotation in panel

The anti-rotation ribs on the housing prevent cam rotation and the resultant panel shift.

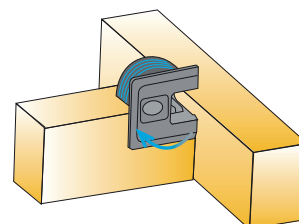

### Comfortable tightening with Angledriv

The Angledriv feature on the cam guides the screwdriver to a 27° angle for comfortable access. The locking action creates a tight, secure fit.

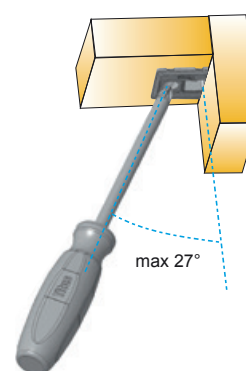

### Easy and quick assembly with Quickfit dowel

Improved 'at-home' assembly experience.

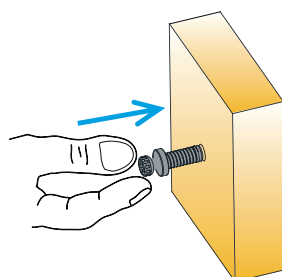

# System 6.2

## Quickfit Dowels

**i** Suitable for System 6.2 only

- Tool-free insertion
- Depth stop collar assures accurate insertion
- Available in Ø5mm and Ø8mm
- For applications with all Titus Sys 6.2 Ø20mm housings

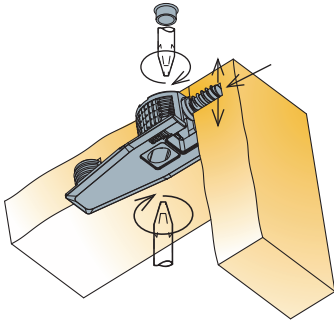

Technical and mounting details

Item number

Dark grey

Quickfit dowel Ø5mm

06576 →

880

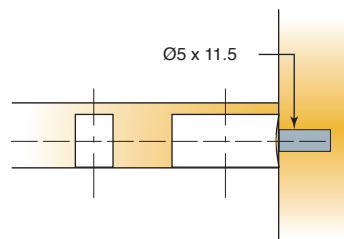

 5000 Pcs

Made of zinc, plastic

Quickfit dowel Ø5mm for back-to-back application

06627 →

880

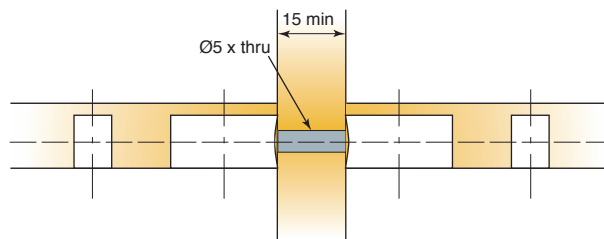

 5000 Pcs

Made of zinc, plastic

Quickfit dowel Ø8mm

06629 →

880

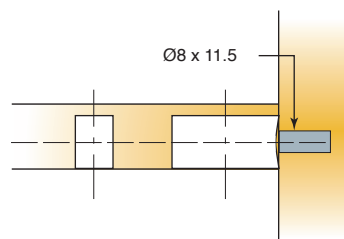











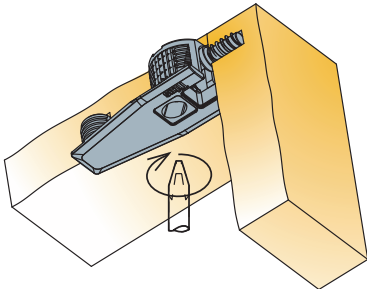



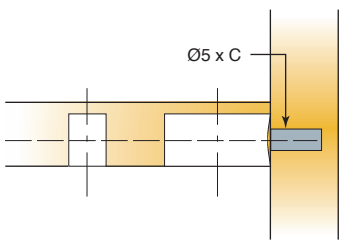

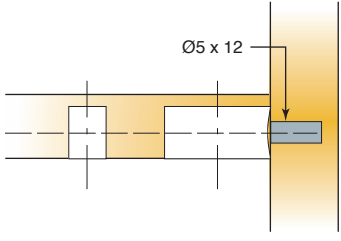

 5000 Pcs

Made of zinc, plastic

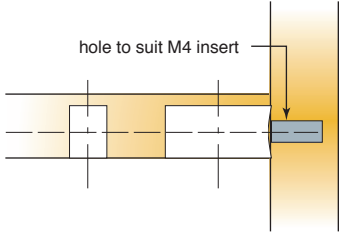
# System 6.2

## Screw-in Dowels

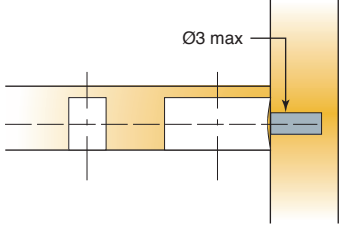
- Available in Ø3mm and Ø5mm thread forms for screw-in, knock-in and 'spiked' hole applications
- For applications with all Titus Sys 6.2 Ø20mm housings
- Dowels feature an integral skirt which acts as a positive stop during insertion

 Technical and mounting details		C	Drilling depth for dowel thread	Item number		
					Zinc plated	Zamak
<b>Dowel Ø5</b>        2000 Pcs Made of zinc or steel	9	06401 →		885		
	8	06402 →	883	885		
	11.5	06406 →	883	885		
<b>Dowel Ø5 x 11 knock-in</b>        2000 Pcs Made of zinc		06403 →		885		
<b>Dowel M4 x 7</b>        4500 Pcs Made of steel		06405 →	883			
<b>Dowel Ø3 x 11.5</b>        12500 Pcs Made of steel		06495 →	883			

 Inserts  
 Made of plastic  
 → see page 1.70

# System 6.2

## Double-ended Dowels

- For 16mm, 18mm and 19mm board
- For applications with all Titus Sys 6.2 Ø20mm housings
- 'Klix' locking feature provides a strong, vibration proof connection

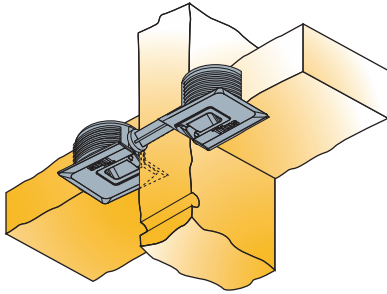

Technical and mounting details

Double-ended dowel

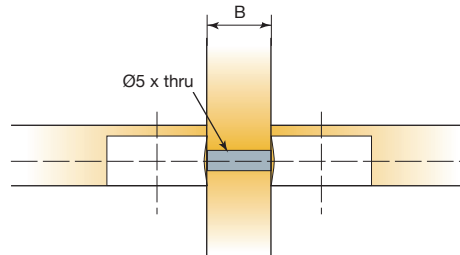
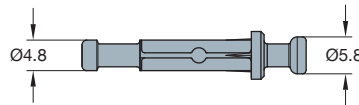

B	Item number	Zinc
Panel thickness		
16	06414 →	885
18	06413 →	885
19	06416 →	885

2500 Pcs

Made of zinc

# System 6.2

## End Dowels

- For 16mm, 18mm and 19mm board
- For applications with all Titus Sys 6.2 Ø20mm housings
- 'Klix' locking feature provides a strong, vibration proof connection

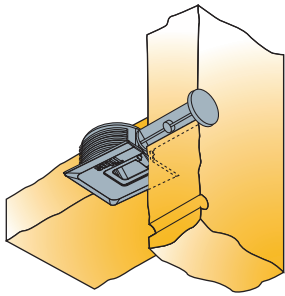

Technical and mounting details

End dowel

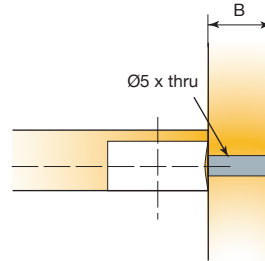
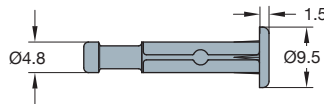

B	Item number	Zinc
Panel thickness		
16	06412 →	885
18	06411 →	885
19	06415 →	885

2000 Pcs  
1000 Pcs (06411)

Made of zinc

# System 6.2

## 20mm Knock-in Housing

- Available in 15mm/16mm and 18mm/19mm versions for drop-on and side-entry applications
- Metal cover cap option
- 'Klix' locking feature provides a strong vibration proof connection
- Compatible with all Sys 6.2 screw-in dowels and Quickfit dowels

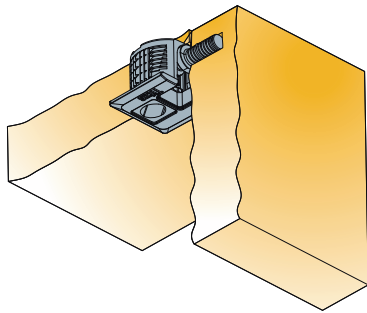

Technical and mounting details

### Side-entry

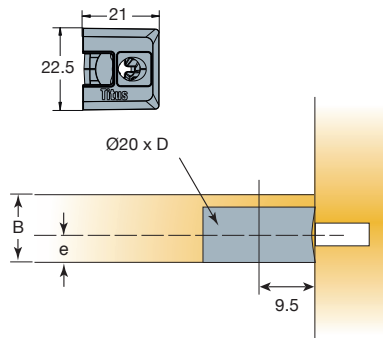

2500 Pcs

Made of plastic

### Drop-on

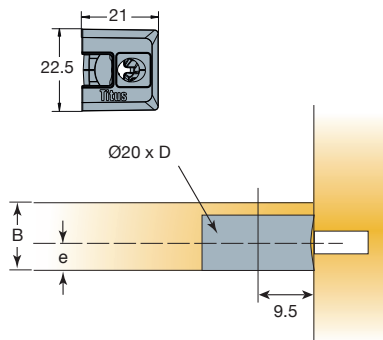

2500 Pcs

Made of plastic

e	B	D	Item number	Silver grey	Dark grey	Dark brown	White
7.75	15/16	12.5	<b>06973</b> →	381	383	831	877
9.25	18/19	14	<b>06977</b> →	381	383	831	877
<i>Other colours on request</i>							
7.75	15/16	12.5	<b>06975</b> →	381	383	831	877
9.25	18/19	14	<b>06979</b> →	381	383	831	877
<i>Other colours on request</i>							

# System 6.2

## Wedgefix Housing (no Inner Cam)

- Available in 15mm/16mm and 18mm/19mm versions
- Compatible with all Sys 6.2 screw-in dowels and Quickfit dowels
- Wedgefix housing allows easy customer hand assembly or factory automated insertion
- When used with Sys 6.2 Quickfit dowels this provides a true toolless fastening system

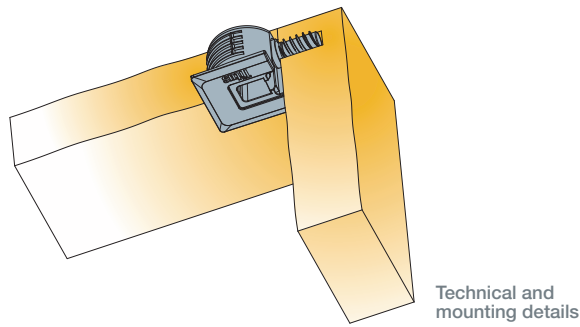

For use with screw-in dowels

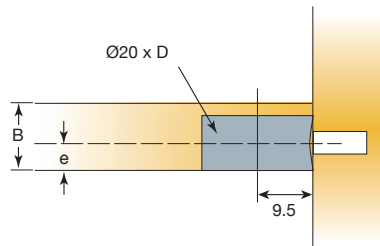
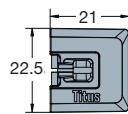

2500 Pcs

Made of plastic

For use with Quickfit dowels

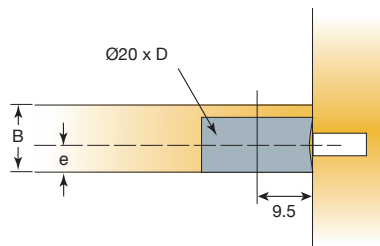
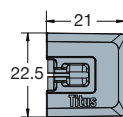

2500 Pcs

Made of plastic

e	B	D	Item number				
Panel thickness	Drilling depth			Silver grey	Dark grey	Dark brown	White
7.75	15/16	12.5	<b>06619</b> →	381	383	831	877
9.25	18/19	14	<b>06620</b> →	381	383	831	877
<i>Other colours on request</i>							
7.75	15/16	12.5	<b>06621</b> →	381	383	831	877
9.25	18/19	14	<b>06622</b> →	381	383	831	877
<i>Other colours on request</i>							

# System 6.2

## Add-on Cover Caps

- Metal cover caps for retrofit mounting
- Enhanced look and contemporary design
- Fits all Sys 6.2 plastic housings

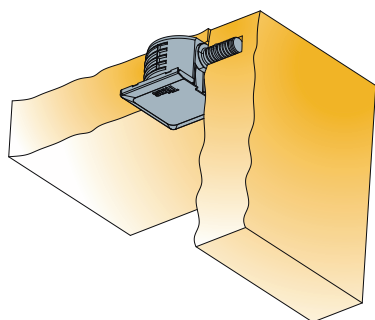

Technical and mounting details

Cover cap for 20mm housing

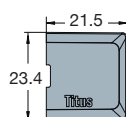

Item number

Nickel plated

Noir

06596 →

054

068

 2050 Pcs

Made of steel



# System 7

## Heavy Duty Connectors

### System Features

A family of heavy duty cams and dowels for offices and public furniture.

- Heavy-duty cam and dowel connector with excellent pull-out and racking strength
- Designed for applications requiring high strength and high performance

- Simple and fast installation
- Suitable for materials such as pine, MDF, and chipboard
- Uses common components with standard drilling patterns
- Suitable for medium to high-value furniture as well as cost-efficient furniture

#### Applications



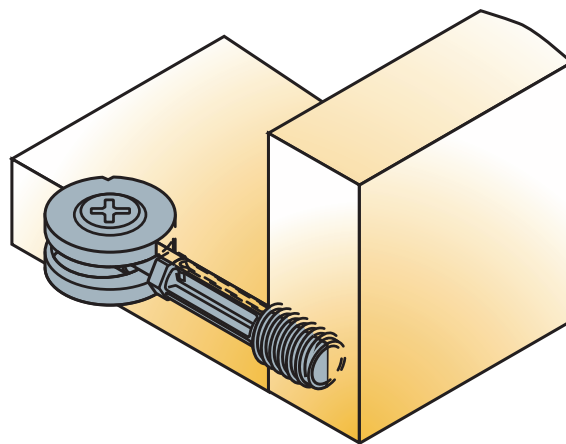

- Suitable for factory insertion and home assembly
- Heavy-duty cabinets, desks, bookcases and large wardrobes, computer furniture, modular panel systems, in-store and retail fixtures, contract office furniture, and platform-style furniture.

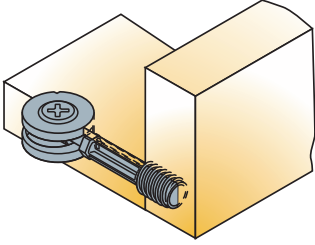

# System 7

## Heavy Duty Ø20mm Cam and Dowel

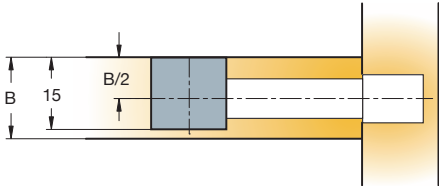
- Dowel available with Ø10mm eurothread and cam available in Ø20mm for a variety of panel thicknesses
- 'Klix' locking feature provides strong, vibration proof joint
- High strength product that eliminates the need for time consuming metal inserts

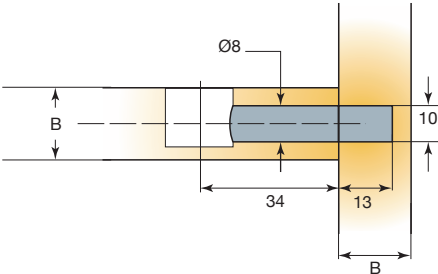





 <p>Technical and mounting details</p>	B	Item number	Zinc
<p>Cam Ø20</p>   <p>500 Pcs      Made of zinc</p>	18	05409 →	885
<p>Dowel Ø7 Ø10 mm thread</p>   <p>500 Pcs      Made of zinc</p>	min 18	05410 →	885

# System 7

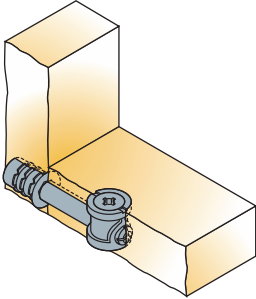
## High Strength Connectors

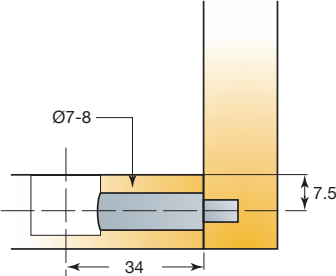
### Contract Fix™ System

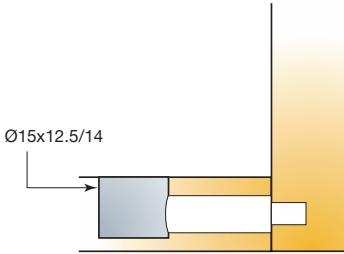
- High performance fastener
- Thread design gives repeatability
- Multi-drive recess
- Higher than average pull-up









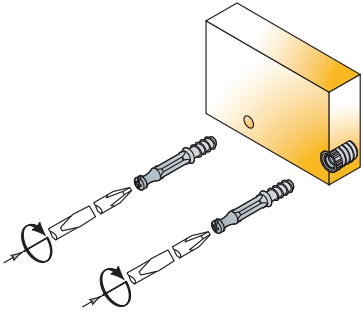

		Item number	Zinc plated	Zinc
 <p>Technical and mounting details</p>				
<p><b>M6 Dowel 7x34</b></p>   <p>1000 Pcs      Made of steel</p>		05971 →	883	
<p><b>Housing cylinder 15x12</b></p>   <p>1000 Pcs      Made of zinc</p>		05960 →		885
<p><b>Grub screw</b></p>  <p>2500 Pcs      Made of zinc</p>		05917 →		885

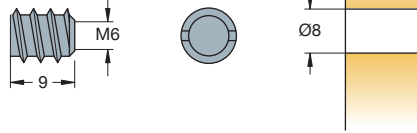
 Inserts  
Made of zinc      → see page 1.70

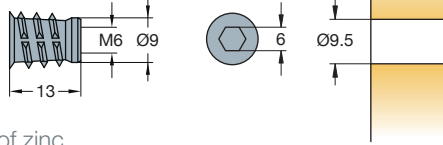
# Accessories for Connectors

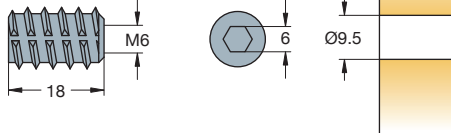
## Inserts

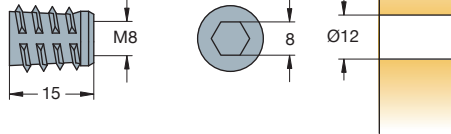
- Available in both zinc and plastic for use in various applications
- For use with various threaded dowels
- For use with various panel thicknesses
- Knock-in and screw-in versions available

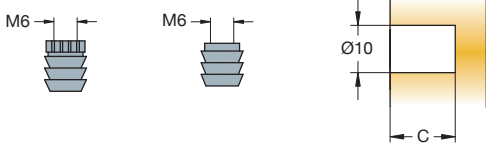
 <p>Technical and mounting details</p>		C	Drilling length for insert	Item number	Natural white	Raw
<p>Ø8 x 9</p>  <p>500 Pcs</p> <p>Made of zinc</p> 	408-3166 →		600			
<p>Ø9 x 13</p>  <p>1000 Pcs</p> <p>Made of zinc</p> 	408-3391 →		600			
<p>Ø9.5 x 18</p>  <p>1000 Pcs</p> <p>Made of zinc</p> 	408-3423 →		600			
<p>Ø12 x 15</p>  <p>1000 Pcs</p> <p>Made of zinc</p> 	408-3424 →		600			
<p>Ø10 x 13/M6 nut</p>  <p>20000 Pcs (275-4035)</p> <p>30000 Pcs (275-4058)</p> <p>Made of plastic</p> 	13	275-4035 →	200			
	11	275-4058 →	200			



# Cabinet Accessories

# Shelf Q-Peg

- Easy and quick installation
- Structural cabinet stability through shelf-to-panel connection
- Minimalistic appearance
- In line with the shelf surface

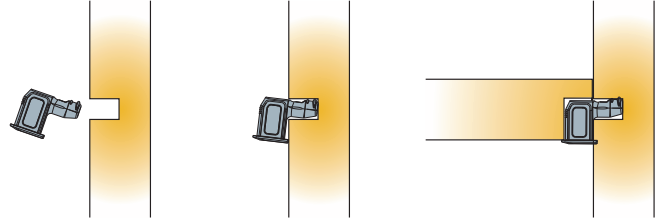

Technical and mounting details

## Shelf Q-Peg Square

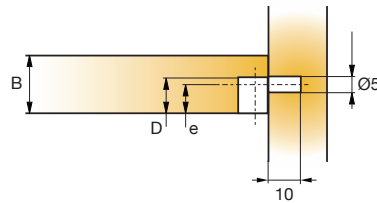
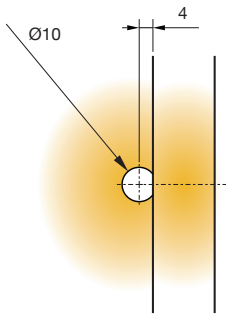
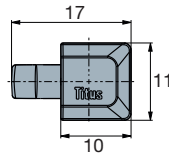
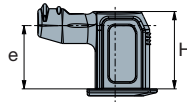

B	D	e	H			
Panel thickness	Drilling depth	Edge to pin hole center	Height	Item number	Nickel plated	Noir
18	11.5	9	11	01924 →	847	668
16	10.3	7.75	9.75	01927 →	847	668

## Capacity chart

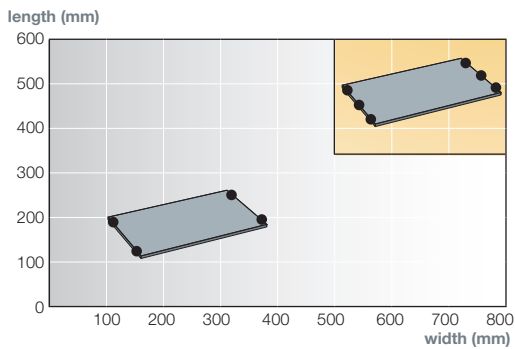







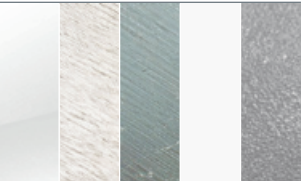
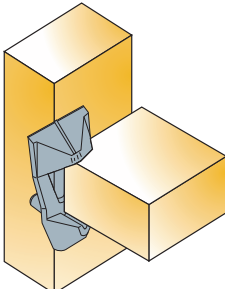

Recommended number of mounted pieces, 4 or 6 per shelf, is determined by its size in accordance with the EN 14749:2016

1000 Pcs

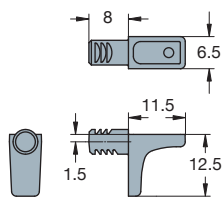
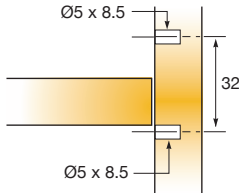
Made of zamak

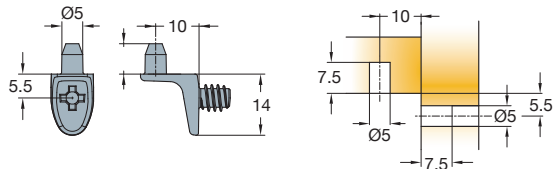
# Shelf Supports

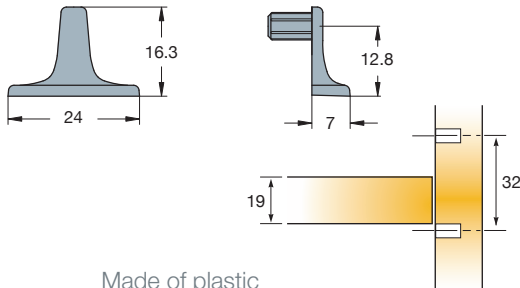

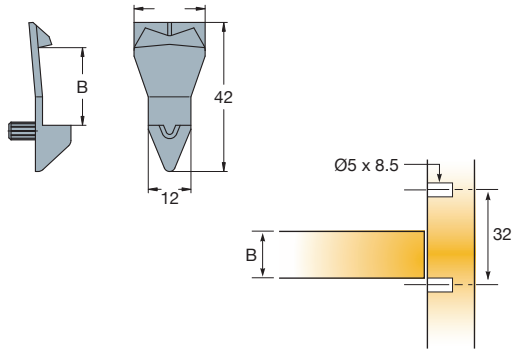



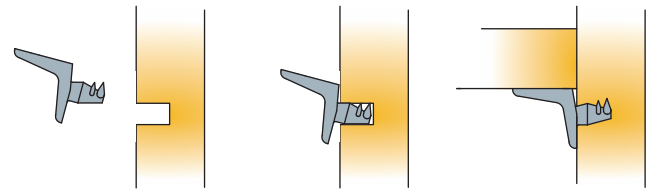

- Hold down feature traps the shelf in place for security
- Folding design allows the shelf to be post mounted in an assembled cabinet
- To suit a wide range of shelf thicknesses
- Pad for metal shelf support when using glass

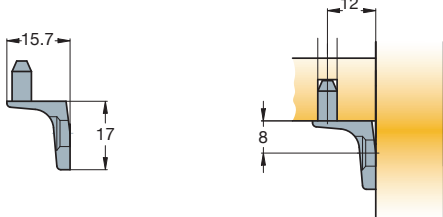
						
		Clear	Nickel	Zinc	White	Silver
		<b>B</b>				
<b>Technical and mounting details</b>		<b>Item number</b>				
<b>Shelf support (push-in)</b>    2000 Pcs Made of zinc		<b>01825</b> →	847	885		
<b>Shelf support (push-in)</b>   2000 Pcs Made of zinc		<b>01852</b> →	847			
<b>Shelf holddown (for use with 01825)</b>   12000 Pcs Made of plastic		<b>01822</b> →				861
<b>Shelf support retainer</b>   4000 Pcs 5000 Pcs (01837) Made of plastic		15 <b>01837</b> →			877	
		16 <b>01838</b> →	830			
		16 <b>*01828</b> →			877	
		18 <b>01823</b> →	830		877	861
		19 <b>01829</b> →			877	
		19 <b>01843</b> →	830			
		<i>* American market only            Other colours on request</i>				

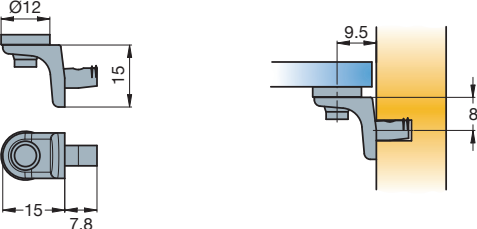
# Shelf Supports

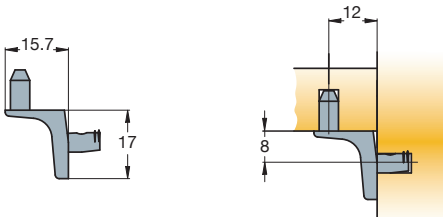
Mounting procedure:

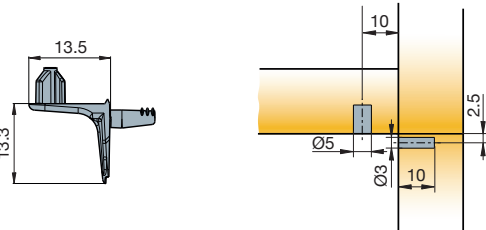

			Item number	Nickel plated
Technical and mounting details				
<p>Pin Ø5x10 (screw-on)</p>  	338-3687 →	650		
 1000 Pcs <p>Made of zinc</p>				
<p>For glass shelves (rock-in)</p>  	338-9721 →	860		
 1000 Pcs <p>Made of zinc and plastic</p>				
<p>Pin Ø5x10 (rock-in)</p>  	338-3686 →	650		
 1000 Pcs <p>Made of zinc</p>				
<p>Shelf support Ø3mm with pin</p>  	01912 →	847		
 2000 Pcs <p>Made of zinc</p>				

# Shelf Supports

		Technical and mounting details	Item number	Nickel plated
Shelf support with pin			01910 →	847
 2000 Pcs	Made of steel			
Shelf support			01911 →	847
 2000 Pcs	Made of steel			
Shelf support with pin			01916 →	847
 2000 Pcs	Made of steel			

# Joining Plates

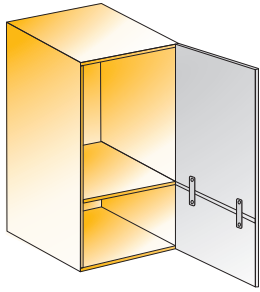

- Rigid and strong
- No pre-drilling
- Spacer pegs provide an even 2mm gap
- Sleek design



Technical details

Item number

Nickel plated

Joining plate 105mm

360-1222 →

054

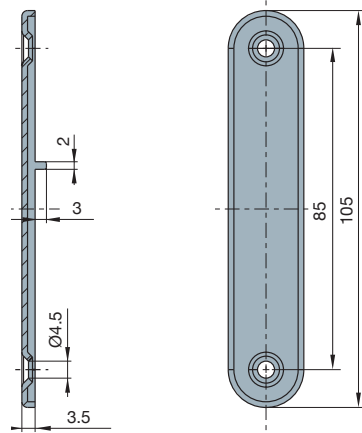

500 Pcs

Made of steel

Joining plate 43mm

360-1230 →

054

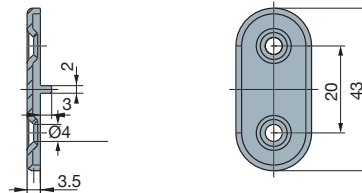

1000 Pcs

Made of steel

Fixing screw

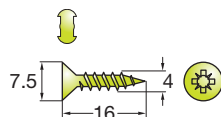

Chipboard screws  
820-6328-050

10000 Pcs

# Backfix Connectors

- Push-in design
- No tools required for Backfix insertion
- The handle acts as a stop during locking, providing greater accuracy and speed of insertion
- Barbs provide a quality fastener for rigid cabinet construction

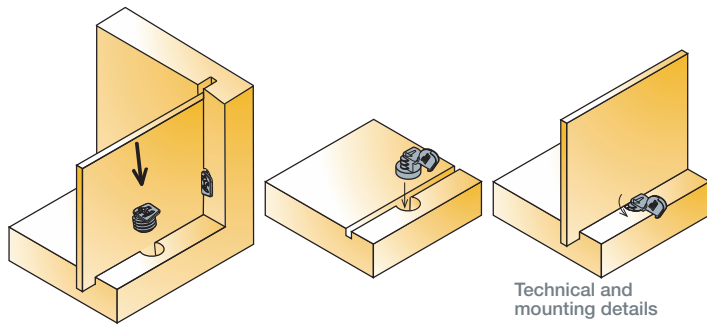

Item number

Zinc

Corrosil

Backfix 2.0

02254 →

885

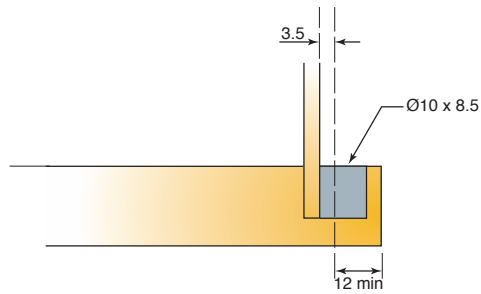
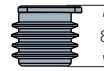
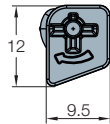

1000 Pcs

Made of zinc

Hardboard  
Backfix-no tools

02154 →

885

897

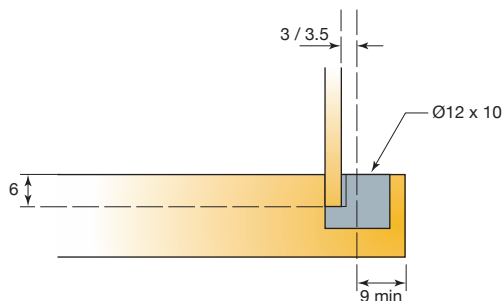

1000 Pcs

Made of zinc

# Back Wall Connectors

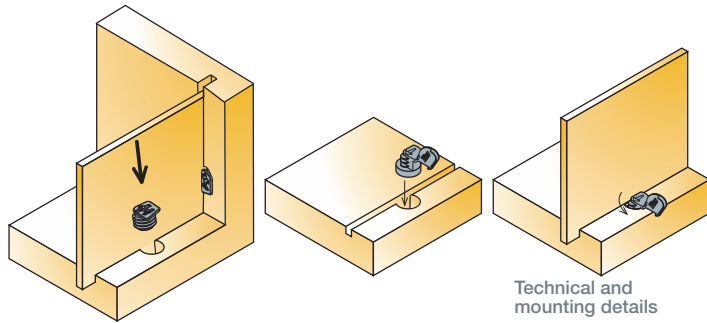

Technical and mounting details

Item number

Nickel plated

Rear wall connector long

353-3649 →

650

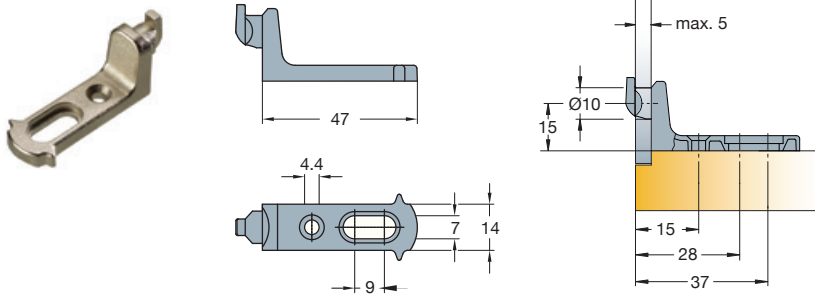

500 Pcs

Made of zinc

Rear wall connector short

353-3650 →

650

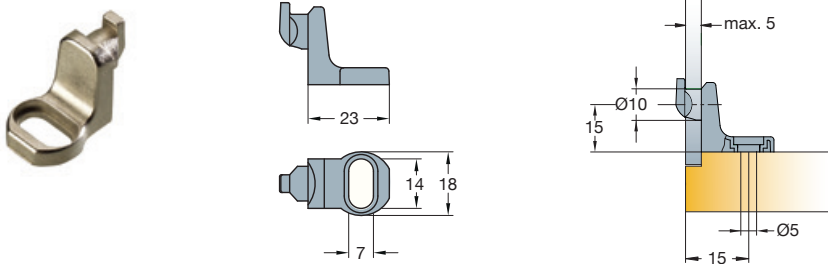

500 Pcs

Made of zinc

# Panel Brackets

- To be used to fix face frames to carcasses without additional drilling to cabinet
- Designed for carcase side panel of 18mm thickness
- Edge to hole centre = 28mm
- Easier fixing of frames due to parts that remain in holes once inserted

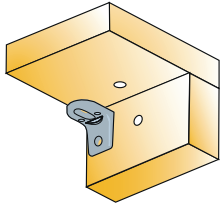

Technical and mounting details

Item number

Nickel plated

Zinc

90° Bracket (screw-in/rock-in peg)

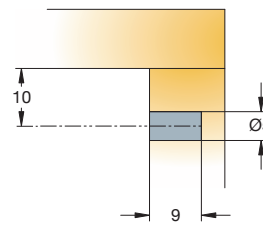
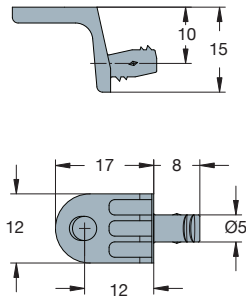

02111 →

847

885

1000 Pcs

Made of zinc

90° Bracket (screw-in)

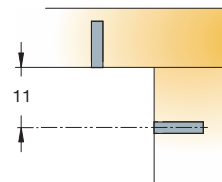
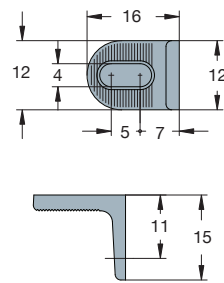

02110 →

847

885

1000 Pcs

Made of zinc

Corner bracket (rock-in)

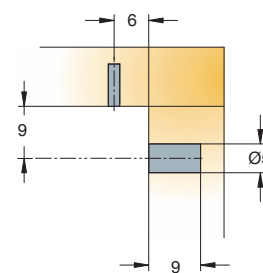
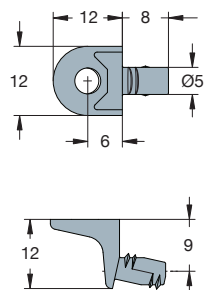

02133 →

885







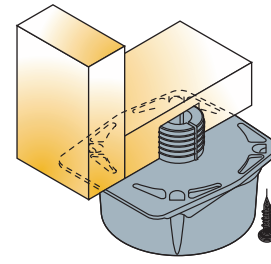

1000 Pcs

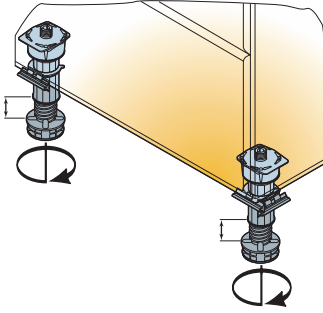
Made of zinc

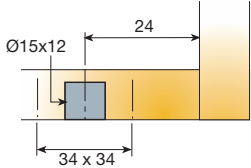

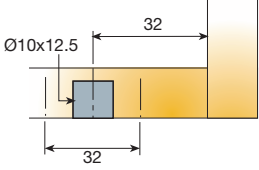

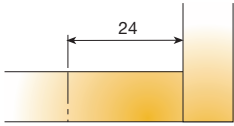
# Adjustable Cabinet Legs

## Leg Top Fixes

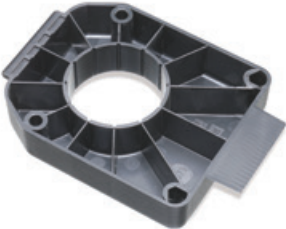
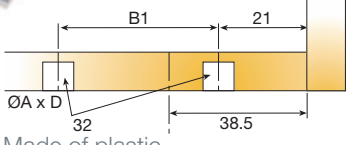

		Technical and mounting details	Item number	Black
Rivet fix	Regular		02560 →	835
	Heavy duty		*02630 →	835
<i>* American market only</i>				
				
 200 Pcs	Made of plastic			
Socket fix (knock in)			02558 →	835
				
 200 Pcs	Made of plastic			
Socket fix (screw on)			02559 →	835
				
 200 Pcs	Made of plastic			

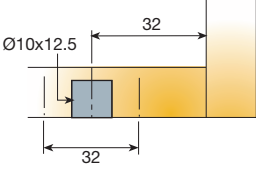
- Lip provides additional support to end panel and gives extra strength
- The side fix has twin dowel mounting for positive location
- Rivet fix design gives quick fastening of socket
- Choice of dowel or screw on sockets
- Invert second clip for corner plinth fixing

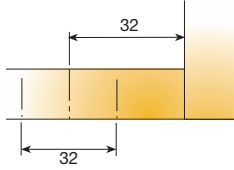
Technical and mounting details		A	D	B1	Item number	Black
		Drilling diameter	Drilling depth	Drilling distance		
<b>Leg top</b> 	(4 screws) screw on	3	6	64 x 64	<b>02575</b> →	835
	(4 dowels + lip) dowel/lip	10	12.5	64 x 64	<b>02582</b> →	835
	(4 screws + lip) screw/lip	3	6	64 x 64	<b>02579</b> →	835
	2 dowels/2 screws	10/3	12.5/6	64 x 64	<b>*02669</b> →	835
	Screw on	3	6	64 x 64	<b>*02671</b> →	835
	Dowels	10	12.5	64 x 64	<b>*02672</b> →	835
 <p>Made of plastic</p>		<i>* Asian market only</i> When using leg top, you must use foot with 01373 clip → see page 3. 8				
<b>Rivet fix/skid</b> 	 <p>Made of plastic</p>				<b>02663</b> →	835
<b>Rivet fix/ no rivet</b> 	 <p>Made of plastic</p>				<b>*02642</b> →	835
		<i>* Asian market only</i>				

100 Pcs







200 Pcs

200 Pcs

# Adjustable Cabinet Leg Range

## Adjustable Leg, Extension and Foot

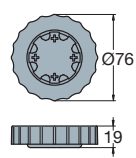
- Legs are supplied assembled at a pre-set height
- Wide adjustment range to fit all common plinth heights
- Jacking point adjustment feature
- Simple push on design to sockets

 Technical and mounting details		B1	H	Item number	Black
		Drilling distance	Fitting height adjustment		
Adjustable leg   					
	Big foot				
	Big foot				
	* Asian market only				
 100 Pcs (02570) 200 Pcs	Made of plastic				
Leg extension			02571 →	835	
 					
 200 Pcs	Made of plastic				
Fixed foot			02569 →	835	
			*02574 →	835	
 					
 200 Pcs	Made of plastic				

# Adjustable Cabinet Leg Range

## Plinth Clips and Fox Clip

- Spring design eliminates the need for drilling and fits into any position on plinth
- The screw in version can sit in variable plinth positions
- When taking plinth around the corner, the fitting is reversible

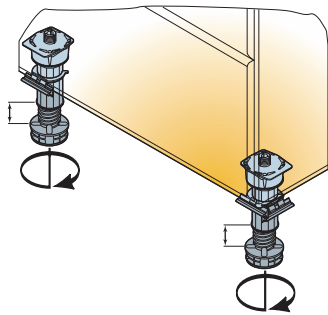

Technical and mounting details

Fox clip

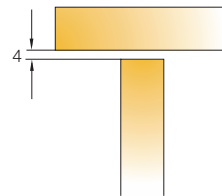

1000 Pcs

Made of plastic

Item number

01373 →

Natural

846

Black

835

Plinth clip 38 screw

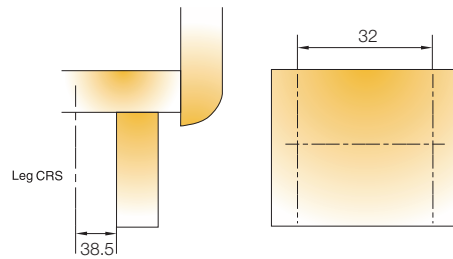

500 Pcs

Made of plastic

02578 →

835

\*02710 →

835

\* Asian market only

Plinth clip 24 knock on

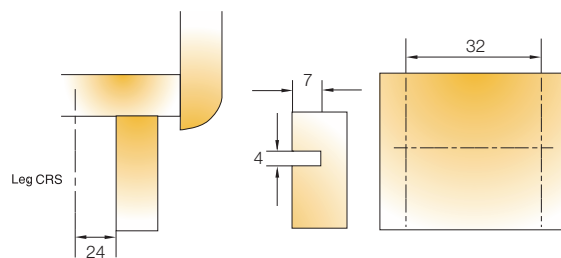

600 Pcs

Made of plastic

02523 →

835

Plinth clip 24 screw on

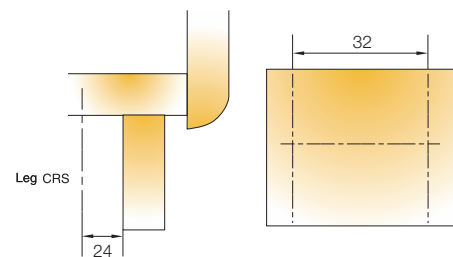

600 Pcs

Made of plastic

02634 →

835

# Drawer Solutions

## Drawer Front Adjuster (DFA)

- Multi-direction adjustment
- Locking screw to fasten
- Independent of drawer system
- One piece housing

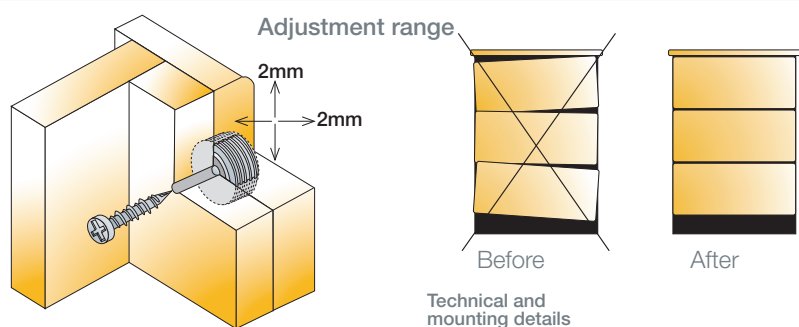

DFA housing

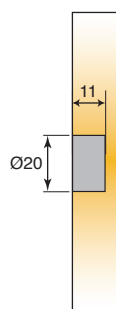

 2500 Pcs

Made of plastic

DFA housing

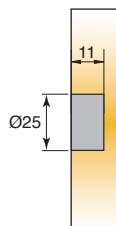
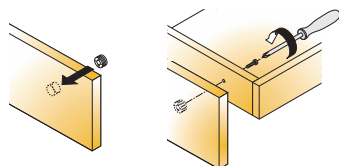

 2500 Pcs

Made of zinc, plastic

Item number	Dark brown	Black	Nickel	White
-------------	------------	-------	--------	-------

06308 →	831			877
---------	-----	--	--	-----

*06310 →	831			877
----------	-----	--	--	-----

*06309 →	831			877
----------	-----	--	--	-----

*00033 →			847	
----------	--	--	-----	--

\*American market only  
\*06309 does not include screw





# Concealed Hinges

# Concealed Hinges

## A Comprehensive Range

### T-type hinge



**Quick furniture assembly and consistent performance on wide range of doors**  
3Way snap-on mounting  
Highly tolerant  
PressTo tool-free hinge cup fixing  
Touch opening for handleless furniture

### S-type hinge



**Simple snap-on mounting system**  
Easy assembly and disassembly  
ConfidentClose  
Touch opening for handleless furniture  
Rigid attachment

### B-type hinge



**Reliable slide-on mounting system**  
ConfidentClose  
Reliable door closing  
Simplicity and versatility

Opening angle	Door thickness	Cranking	Door tab K	Mounting mode	Mounting plate type	Mounting plate height	Soft closing options	Page
95° 110° 120° 170°	15-34mm 15-26mm	0mm 5mm 9mm 17mm angled	3-9mm 3-6mm	'3Way' snap-on	cruciform linear for face frame	0mm 1mm 2mm 3mm 4mm 9mm	Damping integrated in the hinge cup  Glissando add-on or stand-alone damping solutions	2.25
110° 170°	16-24mm	0mm 9mm 15mm angled	3-5mm 3-12mm	snap-on	cruciform for face frame	0mm 1mm 2mm 3mm 6mm 9mm 18mm	Damping integrated in the hinge cup  Glissando add-on or stand-alone damping solutions	2.85
110° 170°	16-24mm	0mm 9mm 15mm angled	3-5mm 3-12mm	slide-on	cruciform	0mm 1mm 2mm 3mm 4mm 5mm 6mm 9mm 18mm	Damping integrated in the hinge cup  Glissando add-on or stand-alone damping solutions	2.129

# Concealed Hinges

## Product Guide

	Cranking	Opening angle	Cup type	Page
<b>T-type</b>				
T-type-i 110	0mm	110°	for wood doors	2.27
	5mm	110°	for wood doors	2.27
	9mm	110°	for wood doors	2.29
	17mm	110°	for wood doors	2.29
T-type-i 110/15°	15°, 9mm	110°	for wood doors	2.31
T-type-i 110/30°	30°, 9mm	110°	for wood doors	2.33
T-type-i 110/45°	45°, 9mm	110°	for wood doors	2.35
	45°, 17mm	110°	for wood doors	2.35
	45° , 23 mm	110°	for wood doors	2.37
T-type-i 110/90° for blind corner	90°, 17mm	110°	for wood doors	2.39
T-type-i 120	0mm	120°	for wood doors	2.41
T-type-i 95	0mm	95°	for wood doors	2.43
	5mm	95°	for wood doors	2.43
	9mm	95°	for wood doors	2.45
	17mm	95°	for wood doors	2.45
T-type-i 170	0mm	170°	for wood doors	2.47
	5mm	170°	for wood doors	2.49
	9mm	170°	for wood doors	2.49
T-type 110	0mm	110°	for wood doors	2.51
	5mm	110°	for wood doors	2.51
	9mm	110°	for wood doors	2.53
	17mm	110°	for wood doors	2.53
T-type 110/15°	15°, 9mm	110°	for wood doors	2.55
T-type 110/30°	30°, 9mm	110°	for wood doors	2.57
T-type 110/45°	45°, 9mm	110°	for wood doors	2.59
	45°, 17mm	110°	for wood doors	2.59

	Cranking	Opening angle	Cup type	Page
<b>T-type</b>				
T-type 110/90° for blind corner	90°, 17mm	110°	for wood doors	2.61
T-type 120	0mm	120°	for wood doors	2.63
T-type 95 thick door hinge	0mm	95°	for wood doors	2.65
	5mm	95°	for wood doors	2.65
	9mm	95°	for wood doors	2.67
	17mm	95°	for wood doors	2.67
T-type 110 unsprung hinge	0mm	110°	for wood doors	2.69
	5mm	110°	for wood doors	2.69
	9mm	110°	for wood doors	2.71
T-type 170	0mm	170°	for wood doors	2.73
	5mm	170°	for wood doors	2.75
	9mm	170°	for wood doors	2.75
T-type for pie-cut corner cabinet			for wood doors	2.77
T-type mounting plates				2.79
T-type mounting plates for face frame cabinets				2.83

	Cranking	Opening angle	Cup type	Page
<b>S-type</b>				
S-type-i3 110	0mm	110°	for wood doors	2.87
	9mm	110°	for wood doors	2.87
	15mm	110°	for wood doors	2.87
S-type-i3 110/15°	15°, 9mm	110°	for wood doors	2.89
S-type-i3 110/24°	24°, 9mm	110°	for wood doors	2.91
S-type-i3 110/30°	30°, 9mm	110°	for wood doors	2.93
S-type-i3 110/45°	45°, 9mm	110°	for wood doors	2.95
	45°, 18mm	110°	for wood doors	2.95
S-type-i3 110/90°	90°, 18mm	110°	for wood doors	2.97
S-type 110	0mm	110°	for wood doors	2.99
	9mm	110°	for wood doors	2.99
	15mm	110°	for wood doors	2.99
S-type 110/-15°	-15°, 0mm	110°	for wood doors	2.101
S-type 110/15°	15°, 9mm	110°	for wood doors	2.103
S-type 110/24°	24°, 9mm	110°	for wood doors	2.105
S-type 110/30°	30°, 9mm	110°	for wood doors	2.107
S-type 110/45°	45°, 9mm	110°	for wood doors	2.109
	45°, 18mm	110°	for wood doors	2.109
S-type 110/90°	90°, 18mm	110°	for wood doors	2.111
S-type 110 AL	0mm	110°	for aluminium frame doors	2.113
	9mm	110°	for aluminium frame doors	2.113
	15mm	110°	for aluminium frame doors	2.113
S-type 110 unsprung hinge	0mm	110°	for wood doors	2.115

	Cranking	Opening angle	Cup type	Page
<b>S-type</b>				
S-type 170	0mm	170°	for wood doors	2.117
	9mm	170°	for wood doors	2.119
S-type for pie-cut corner cabinet			for wood doors	2.121
S-type mounting plates				2.123
S-type mounting plates for face frame cabinets				2.127

	Cranking	Opening angle	Cup type	Page
<b>B-type</b>				
B-type-i3 110	0mm	110°	for wood doors	2.131
	9mm	110°	for wood doors	2.131
	15mm	110°	for wood doors	2.131
B-type-i3 110/30°	30°, 9mm	110°	for wood doors	2.133
B-type-i3 110/45°	45°, 9mm	110°	for wood doors	2.135
	45°, 18mm	110°	for wood doors	2.137
B-type-i3 95°/90°	90°, 18mm	95°	for wood doors	2.139
B-type 110	0mm	110°	for wood doors	2.141
	9mm	110°	for wood doors	2.141
	15mm	110°	for wood doors	2.141
B-type 110/30°	30°, 9mm	95°	for wood doors	2.143
B-type 110/45°	45°, 9mm	110°	for wood doors	2.145
	45°, 18mm	110°	for wood doors	2.147
B-type 110°/90°	90°, 0mm	110°	for wood doors	2.149
	90°, 18mm	95°	for wood doors	2.149
B-type 110 AL	0mm	110°	for aluminium frame doors	2.151
	9mm	110°	for aluminium frame doors	2.151
	15mm	110°	for aluminium frame doors	2.151
B-type 110 AL (Glissando AL ready)	0mm	110°	for aluminium frame doors	2.153
	9mm	110°	for aluminium frame doors	2.153
	15mm	110°	for aluminium frame doors	2.153
B-type 170	0mm	170°	for wood doors	2.155
	9mm	170°	for wood doors	2.157
B-type for pie-cut corner cabinet			for wood doors	2.159
B-type flap door hinge	0mm	90°	for wood doors	2.161
B-type mounting plates				2.163

	Opening angle	Cup type	Page
--	---------------	----------	------

## Other Hinges and Accessories

Wide angle hinge and mounting plate	270°	for wood doors	2.167
Refrigerator cabinet hinge and mounting plate	100°	for wood doors	2.169
Hinge angle restrictors			2.171
Cover caps			2.173

## Glissando Soft Closing Systems for Hinges

Glissando TT			2.183
Glissando TL3			2.183
Glissando TL 170			2.185
Glissando AL			2.187
Glissando CR			2.189

## TouchControl Solutions

Push Latch S3			2.193
Push Latch S2			2.197
Push Latch			2.199
PushOpen Short			2.201
PushOpen Long			2.203

# Concealed Hinges

## Door Overlay

### How to Achieve the Desired Door Overlay?

#### By choosing the hinge of appropriate cranking

Concealed hinges with specific hinge arms are available for different door overlays. The most common overlays are:

■ Cabinet side  
■ Door

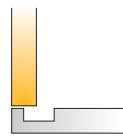

- 1. Full overlay**  
Use a hinge with 0mm cranking

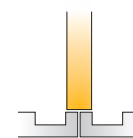

- 2. Partial overlay for double doors**  
Use a hinge with 5mm or 9mm cranking



- 3. Inset door**  
Use a hinge with 15mm or 17mm cranking

#### By choosing the mounting plates of appropriate thickness

To achieve the desired overlay (x) while using a determined drilling distance (K), a mounting plate of appropriate

thickness (D) must be chosen from the enclosed table or calculated with given formula.

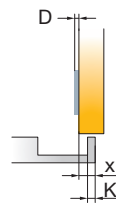

x	4	5	6	7	8	9
3	3	2	1	0		
K 4		3	2	1	0	
5			3	2	1	0

$$D=4+K-x$$

#### By choosing the appropriate drilling distance K

To achieve the desired door overlay (x) while using a determined mounting plate thickness (D), an appropriate drilling distance K must be chosen.

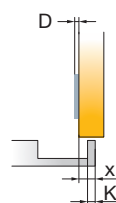

x	4	5	6	7	8	9
0				3	4	5
1			3	4	5	
D 2				5		
3	3	4	5			

### Through side adjustment

Side adjustment is made by rotating the appropriate screw on the hinge arm.

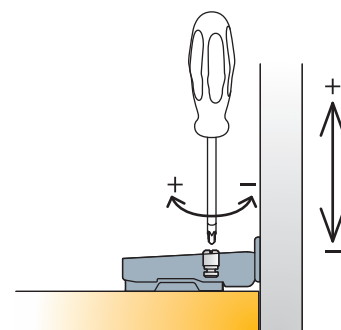
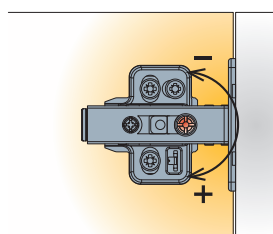

### Door clearance and gap

Door clearance ( $F \geq F_{min}$ ) and gap ( $Z$ ) represent the minimal necessary space needed for the correct opening and closing of the door. The minimal required values depend on the cup drilling distance ( $K$ ), door thickness ( $V$ )

and the type of hinge. The minimum clearance scale can be found on product pages → see Door clearance chart. When using hinges with partial overlay the door clearance must be twice as large ( $F \geq 2F_{min}$ ).

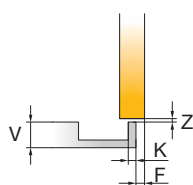

V	16	17	18	19	20	21	22
3	0.3	0.5	0.7	1.0	1.3	1.7	2.5
K 4	0.3	0.5	0.7	0.9	1.2	1.6	2.1
5	0.3	0.5	0.7	0.9	1.2	1.5	2.0 $F_{min}$

Gap  $Z_{min}=0$

# Concealed Hinges

## Hinge Cup Types

### How to Mount the Hinge on the Door?

There are cup type symbols listed on product pages beside item numbers. Below you can find their explanation.

There are cup type symbols listed on product pages beside item numbers. Below you can find their explanation.

#### No pre-mounting

The hinge is fixed on the door with two screws. 3mm pilot holes recommended.

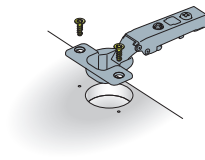

#### **PressTo** tool-free mounting

The hinge is inserted into cup hole and locked in place without tools

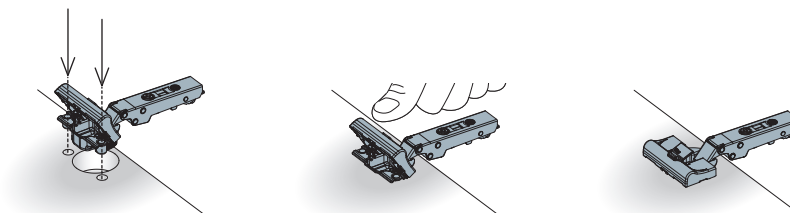

#### **EasyFix**

Quarter turn fixing for 8mm holes (interaxis 45/9.5) or 10mm holes (interaxis 48/6 and 52/5.5).

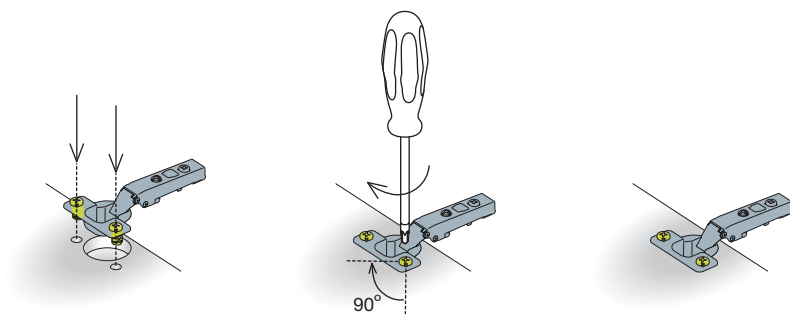



**Machine insertion ready hinge cup**

Pre-mounted dowels suitable for machine insertion into 8mm holes (interaxis 45/9.5) or 10mm holes (interaxis 48/6 and 52/5.5)

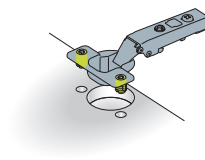

**FastFix**

Pre-mounted expanding dowels with triple-start screw for fast fixing, suitable for 8mm holes.

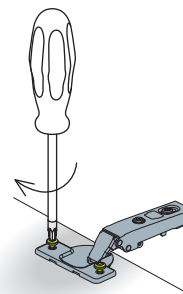
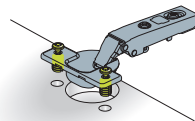

# Concealed Hinges









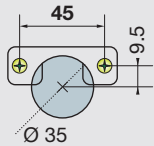
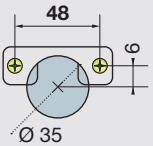

## Drilling Details

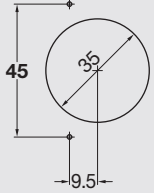
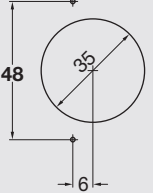
### Drilling Patterns for Hinge Cup

**Interaxis**  
45mm, 48mm and 52mm\*

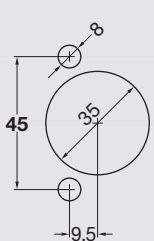
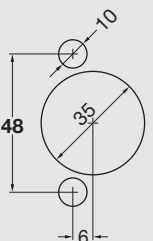
· T-type, S-type, B-type

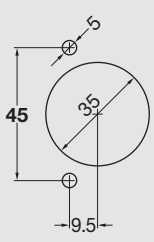
\*Available on special request → see page 0.3

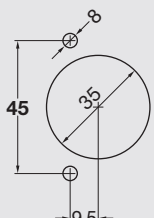
	Interaxis 45mm	Interaxis 48mm
<p>Hinge cup type</p>	 <p>Drilling pattern</p>	 <p>Drilling pattern</p>
<p>Screw-on ready</p>  <p>Pre-mounted Ø4.5mm screws</p> 		
<p>Machine insertion ready</p>  <p>FastFix</p>  <p>EasyFix</p> 		
<p>Pre-mounted euro screws</p> 		
<p>Tool-less mounting</p>  <p>PressTo</p>		

Interaxis is the distance between two holes center for fixing screws on the hinge cup.

# Concealed Hinges

## Mounting Plate Type

### How to Fix the Mounting Plate on the Cabinet Side?

There are mounting plate type symbols listed on product pages beside item numbers. Below you can find their explanation.



#### Chipboard screw-on ready

Mounting plate is fixed with two chipboard screws or equivalent. 3mm pilot holes recommended.

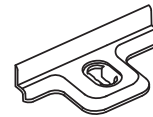

#### Euro screw ready

Fixing with 6.3mm euro screws into pre-drilled 5mm holes. To choose appropriate head and length for use with this mounting plate is recommended.

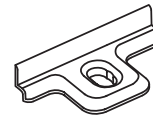

#### Machine insertion ready

Pre-mounted dowels for machine insertion into pre-drilled 10mm holes.

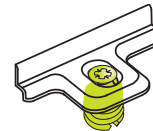

#### Pre-mounted euro screws

Euro screws for 5mm holes are pre-mounted on the mounting plate. Available lengths: 11mm, 13mm and 15mm

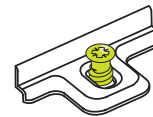

#### Pre-mounted expanding dowels

Pre-mounted expanding dowels for 5mm holes. Available lengths: 7.5mm and 10.5mm

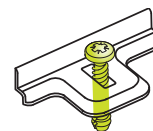

#### Pre-mounted Ø4.5mm screws

Mounting plate is fixed with two pre-mounted chipboard screws. 3mm pilot holes recommended.

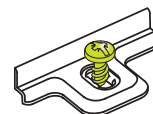

# Concealed Hinges

## Hinge-to-plate Mounting

### How to Assemble the Hinge and the Mounting Plate?

#### T-type 3Way snap-on

3Way snap-on mounting for intuitive hinge-to-plate assembly in three directions:

- from the hinge arm front
- from the hinge arm rear
- from the top

rear assembly

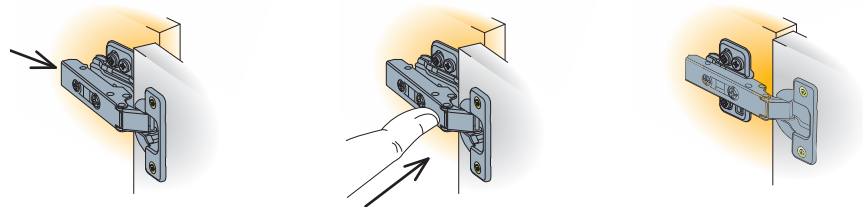

front assembly

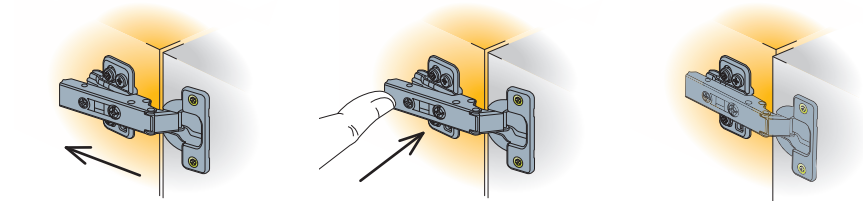

top assembly



disassembly:  
for disassembly press rear  
lever on the hinge arm.

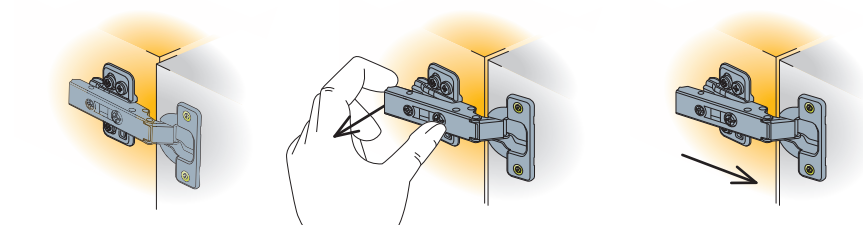

### S-type snap-on

Door is assembled on the cabinet side simply by positioning the two hooks under the hinge arm on the outer part of the mounting plate and pressing gently on the rear part of the hinge arm.

For disassembly press the rear button on the hinge arm.

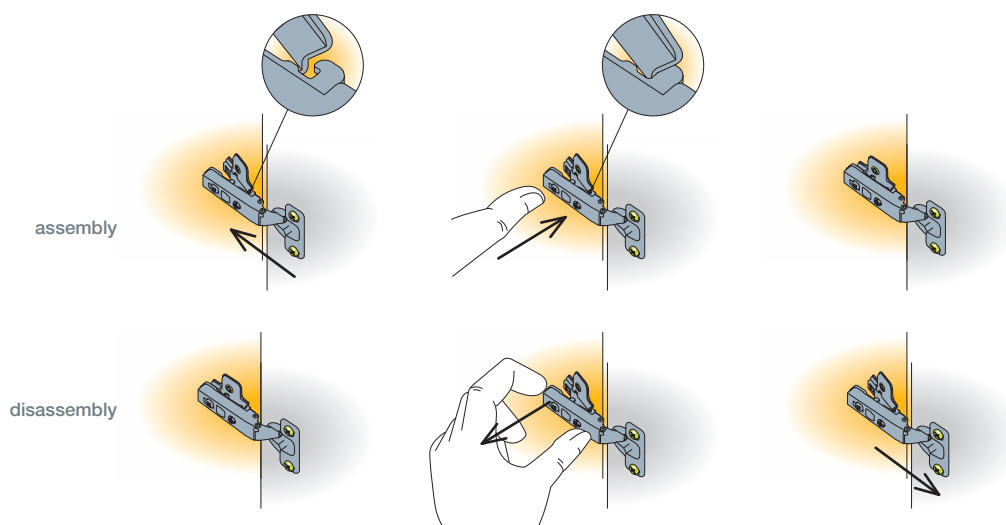

### B-type slide-on

Hinge is assembled by sliding the hinge arm over the mounting plate. The hinge adjustment screw must fit into the groove on the mounting plate.

After adjusting the door depth, the mounting procedure is finished by tightening the fixing screw.



### Key-hole

- Wide angle hinge
- Refrigerator cabinet door hinge

Hinge is assembled on the mounting plate by inserting the fixing screw on the appropriate hole on the hinge arm.

After adjusting the door depth, the mounting procedure is finished by tightening the fixing screw.

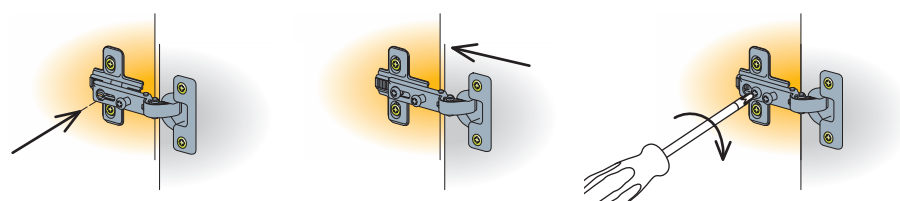

# Concealed Hinges

## Loads

### How Many Hinges per Door?

Check the enclosed recommendation for the number of recommended hinges per door by considering door height and weight.

Hinges to be positioned as far apart as possible.

Recommendation:  
Use the appropriate number of hinges, not exceeding door height and weight as shown below.

- Self-closing hinges
- Hinges without spring
- Hinges with integrated damping

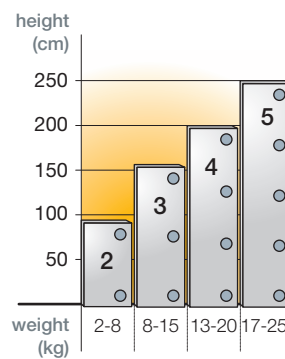

T-type  
T-type-i

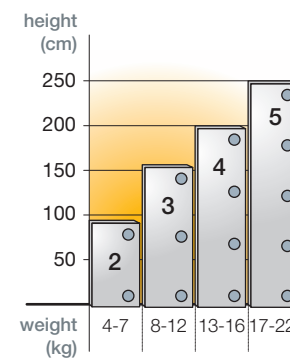

S-type  
B-type  
S-type-i3  
B-type-i3

Hinges with integrated damping can be combined with non-damped hinges from standard hinge range. A trial mounting is always recommended.

# Concealed Hinges

## Adjustments



Adjustment range can be found on the product pages.

### Side Adjustment

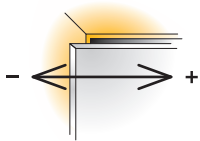

Side adjustment aligns the door with the side of the cabinet.

#### By rotating the adjustment screw

- T-type
- S-type
- B-type

Side adjustment is made by rotating the screw on the hinge arm.

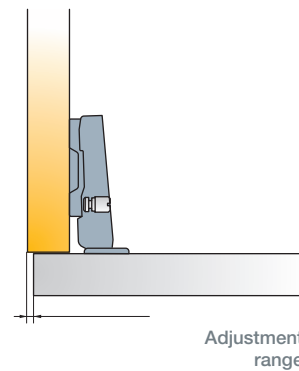
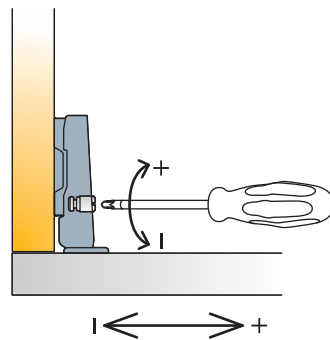
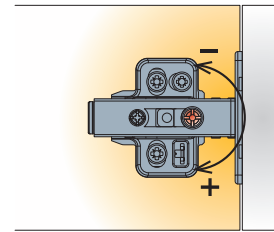

#### By temporarily loosening the fixing screw

- Wide angle hinge 270°
- Refrigerator cabinet hinge

For the side adjustment:

1. Release the fixing screw
2. Make the necessary adjustment by rotating the appropriate screw
3. Tighten the fixing screw

Without releasing the fixing screw no side adjustment is possible.

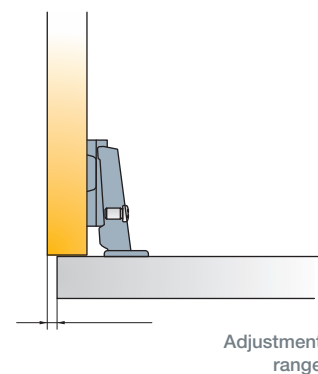
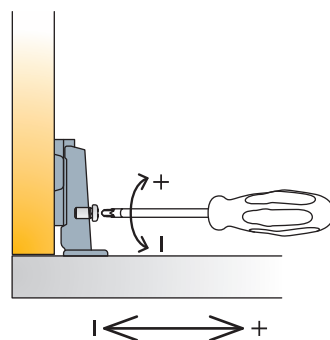

# Concealed Hinges

## Adjustments

### Height Adjustment

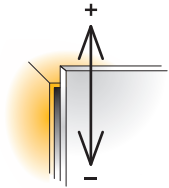

Height adjustment is necessary to achieve optimal vertical door position.

#### By rotating the cam adjuster

Height adjustment is made by rotating the cam adjuster on the mounting plate.

T-type with cam adjustable cruciform mounting plate

S-type with cam adjustable cruciform mounting plate

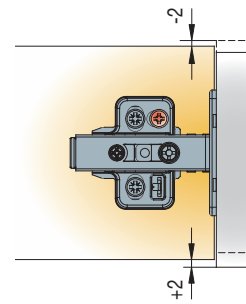
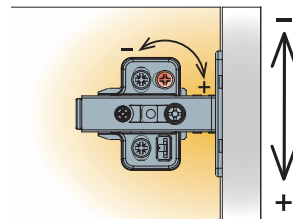

T-type with cam adjustable horizontal mounting plate

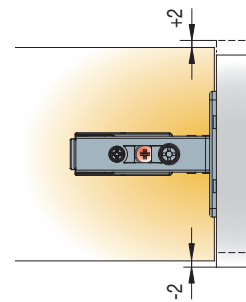
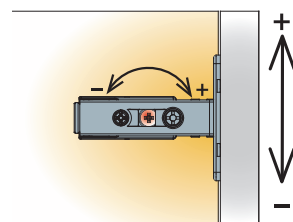

#### By releasing the fixing screws

For height adjustment the two mounting plate fixing screws have to be temporarily released while making the manual adjustment.

- T-type, S-type and B-type with cruciform mounting plate
- Wide angle hinge 270°
- Refrigerator cabinet hinge

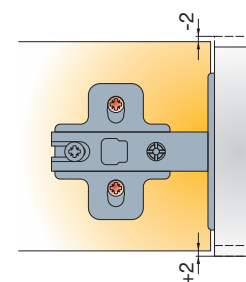
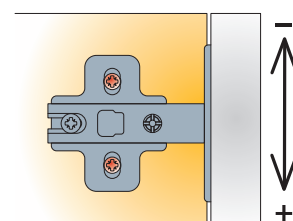

# Concealed Hinges

## Adjustments



Adjustment range can be found on the product pages.

### Depth Adjustment

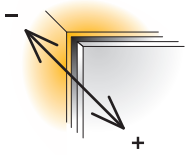

The system enables easy adjustment of the gap between door and cabinet.

#### By rotating the cam adjuster

Rotate the cam adjuster on the hinge arm.

- T-type

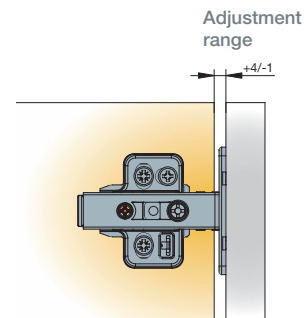
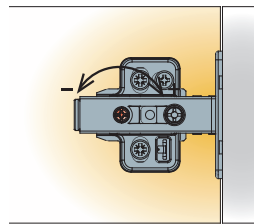

#### By releasing the fixing or adjustment screw

- S-type
- B-type

The depth adjustment is made by temporarily releasing the adjustment screw (S-type) or fixing screw (B-type). After the adjustment is made the screw has to be re-tightened.

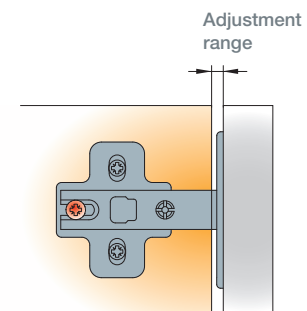
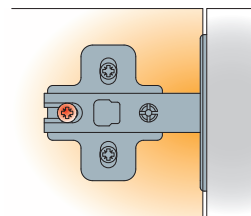

# Concealed Hinges

## Adjustments

### Damping Adjustment

T-type-i

The damping action can be adjusted to fit different door weights and sizes which enables optimal door functioning.

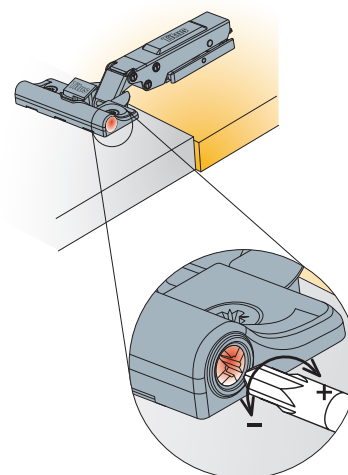

Damping is factory pre-set to the medium damping value.  
Turn towards '+' to increase and '-' to decrease the damping.

## Key Design Choices

### ConfidentClose

The hinge is designed to provide consumer preferred way of soft closing action.

*Based on results of Titus researches made in UK, Germany and Slovenia*

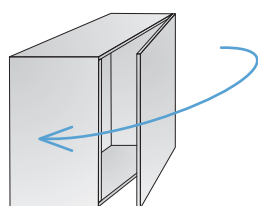

Fast closing

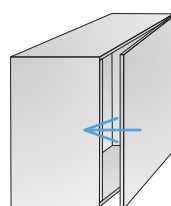

Late start of deceleration action

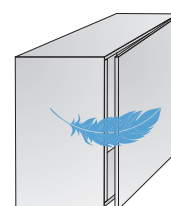

Quiet landing with SoftTouch

### One-for-all efficiency principle

Damping on the hinge cup  
Damper, positioned transversal to the hinge cup allows for easy introduction of hinge versions

Damped and non-damped version on one mounting plate platform

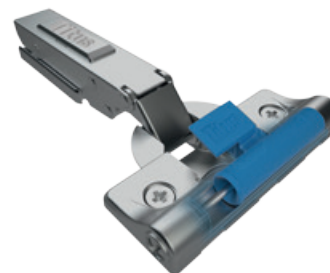

### Adjustable damping

Flexibility to tune performance for all applications

- Consistent performance over a wide range of doors of different sizes and weights
- Easy accessible adjustment button for intuitive and quick adjustment

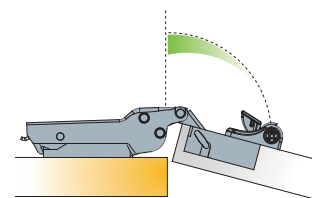

Adjustable damping zone and force

### Titus Damper Inside

- Efficient damping at any closing speed
- Reliable closing
- Damping force consistency



# T-type Hinges

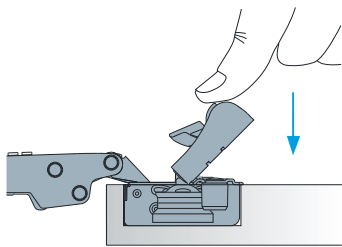

## T-type PressTo Tool-free hinge cup fixing

- Effortless press-in locking
- Confident locking action
- Reliable door attachment
- Confident and repeatable assembly



## T-type-i 170

- Wide angle hinge with integrated damping
- Zero-protrusion opening angle makes it ideal for interior drawers application

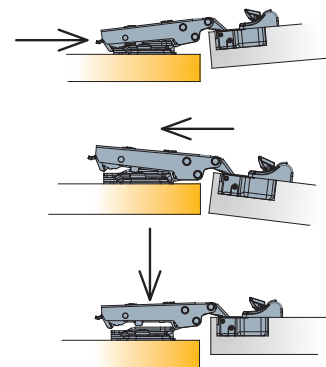

## 3Way snap-on mounting

- Mounting from three directions: rear, front, top
- Reduced assembly time

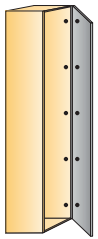

### Easy door installation even on tall and heavy door

- Easy mounting of doors with four or more hinges

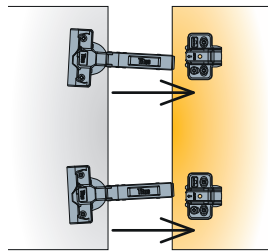

### Highly tolerant

- Efficient performance in edge value of tolerances
- Reliable door closing in case of accidental misalignment
- ConfidentClose assured

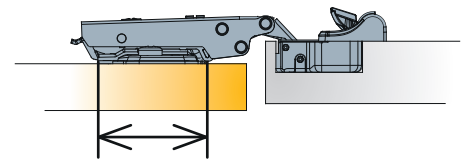

### Rigidity

- Tight hinge-to-plate joint improves hinge stability and reduces door sag
- Enhanced door stability
- Smooth performance

# T-type-i 110

For wood doors

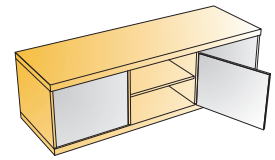
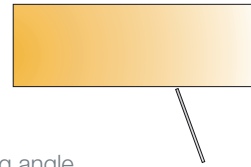
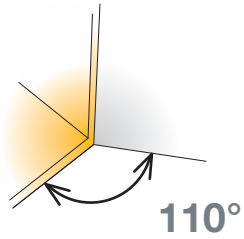

- Opening angle
- Drilling diameter for hinge cup
- Drilling depth
- Hinge on plate mounting system

110°  
35mm  
12mm,  
12.5mm PressTo  
3Way snap-on



Technical details

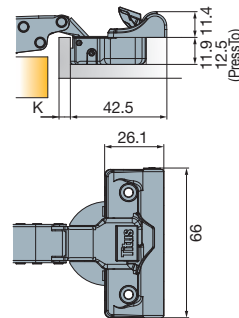

Cup type	Interaxis 45mm	Interaxis 48mm
Item number		

Cranking  
0mm



	701-0AT0-054	701-0AS0-054
	701-0AT1-054	701-0AS1-054
	701-0AT4-054	701-0AS4-054
	701-0AT6-054	

Drilling patterns for hinge cups → see page 2.15

150 Pcs Made of steel

Cranking  
5mm

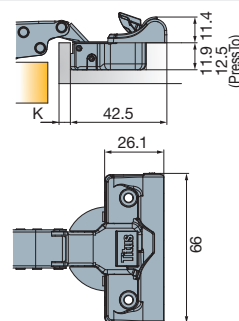

	701-0BT0-054	701-0BS0-054
	701-0BT1-054	701-0BS1-054
	701-0BT4-054	701-0BS4-054
	701-0BT6-054	

Drilling patterns for hinge cups → see page 2.15

150 Pcs Made of steel

Mounting plates  
→ see pages 2.79-2.84



Cover caps for hinge arm  
→ see page 2.173



Hinge cup screws  
If not pre-mounted

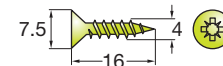

820-6328-050  
 10000 Pcs

Hinge angle restrictor  
→ see page 2.171



TouchControl solutions  
→ see pages 2.193-2.204



Damping adjustment

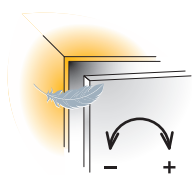

Door adjustment

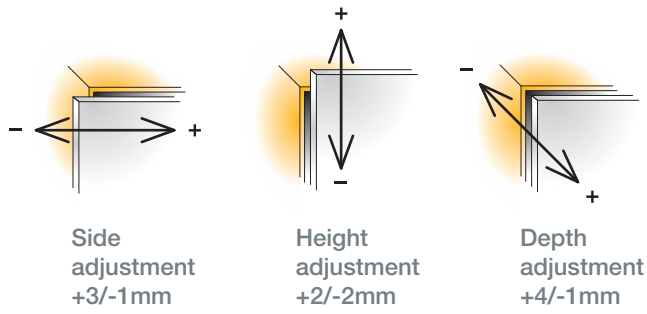

For further explanation → see page 2.23

For further explanation → see pages 2.20-2.22

Mounting details

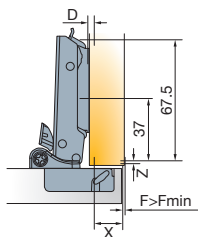
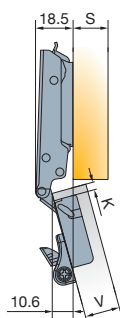

Mounting plate drilling distance

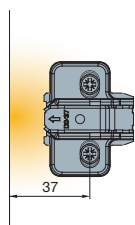

Mounting plate thickness table

For further explanation → see page 2.11

X	13	14	15	16	17	18	19
3	3	2	1	0			
4	4	3	2	1	0		
K							
5		4	3	2	1	0	
6			4	3	2	1	0
							D

$D=13+K-X$

Drawings show application on D=0mm mounting plate

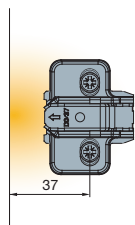
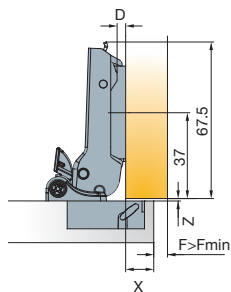
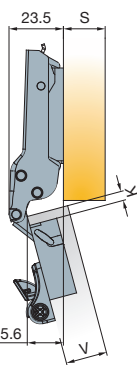

X	8	9	10	11	12	13	14
3	3	2	1	0			
4	4	3	2	1	0		
K							
5		4	3	2	1	0	
6			4	3	2	1	0
							D

$D=8+K-X$

Drawings show application on D=0mm mounting plate

Door clearance at R=1mm

For further explanation → see page 2.12

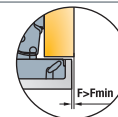

V	16	17	18	19	20	21	22	23	24	25	26
3	0.5	0.7	0.8	1	1.2	1.5	1.7	2.1	2.8	4.1	5.5
4	0.4	0.7	0.8	1	1.2	1.5	1.7	2.1	2.3	3.1	4.5
K											
5	0.4	0.6	0.7	0.9	1.1	1.4	1.6	2	2.2	2.6	3.5
6	0.4	0.6	0.7	0.9	1.1	1.4	1.6	2	2.2	2.6	2.9
											F <sub>MIN</sub>

Gap Z<sub>MIN</sub>=0

# T-type-i 110

For wood doors

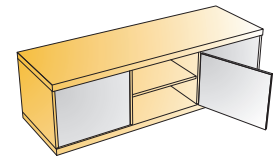
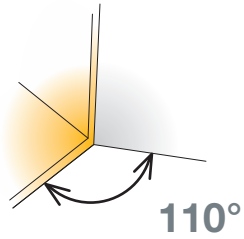

- Opening angle
- Drilling diameter for hinge cup
- Drilling depth
- Hinge on plate mounting system

110°  
35mm  
12mm,  
12.5mm PressTo  
3Way snap-on



Technical details

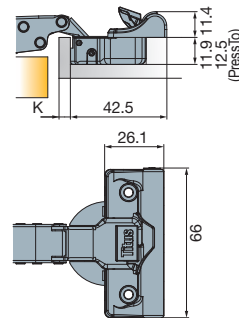

Cup type	Interaxis 45mm	Interaxis 48mm
	Item number	Item number

Cranking  
9mm

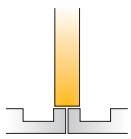

	701-OCT0-054	701-OCS0-054
	701-OCT1-054	701-OCS1-054
	701-OCT4-054	701-OCS4-054
	701-OCT6-054	

Drilling patterns for hinge cups → see page 2.15

150 Pcs

Made of steel

Cranking  
17mm

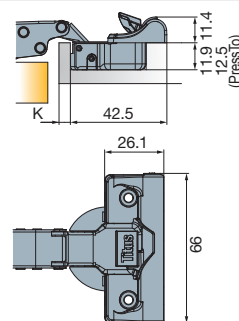
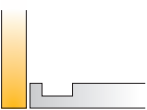

	701-ODT0-054	701-ODS0-054
	701-ODT1-054	701-ODS1-054
	701-ODT4-054	701-ODS4-054
	701-ODT6-054	

Drilling patterns for hinge cups → see page 2.15

150 Pcs

Made of steel

Mounting plates  
→ see pages 2.79-2.84



Cover caps for hinge arm  
→ see page 2.173



Hinge cup screws  
If not pre-mounted

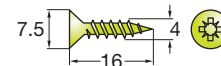

820-6328-050  
10000 Pcs

Hinge angle restrictor  
→ see page 2.171



TouchControl solutions  
→ see pages 2.193-2.204



Damping adjustment

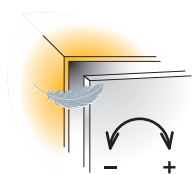

Door adjustment

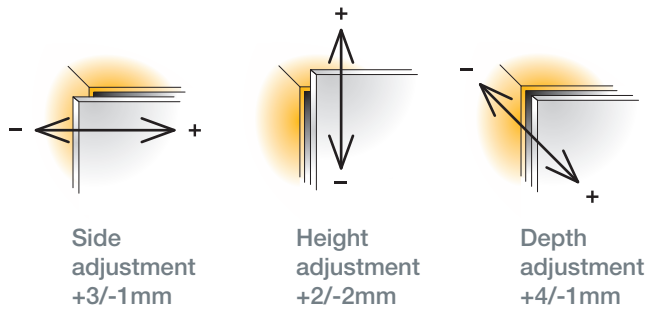

For further explanation → see page 2.23

For further explanation → see pages 2.20-2.22

Mounting details

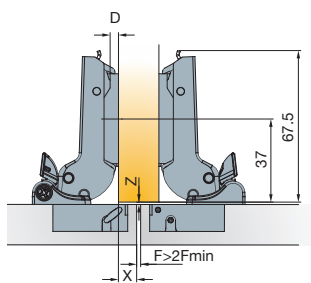
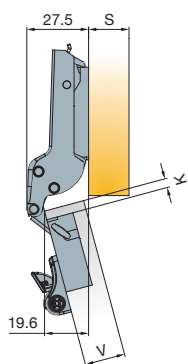

Mounting plate drilling distance

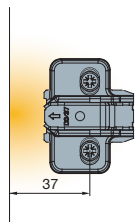

Mounting plate thickness table

For further explanation → see page 2.11

X	4	5	6	7	8	9	10
3	3	2	1	0			
4	4	3	2	1	0		
K							
5		4	3	2	1	0	
6			4	3	2	1	0
							D

$D=4+K-X$

Drawings show application on D=0mm mounting plate

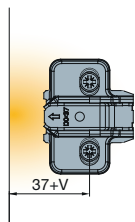
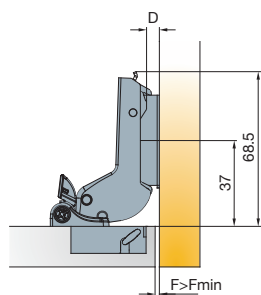
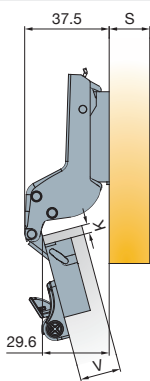

V	16	17	18	19	20	21	22	23	24
3	0	0	0	0	1	1	1	1	2
4	1	1	1	1	2	2	2	2	3
K									
5	2	2	2	2	3	3	3	3	4
6	3	3	3	3	4	4	4	4	
									D

$D=-4+K+F$

Drawings show application on D=2mm mounting plate

Door clearance at R=1mm

For further explanation → see page 2.12

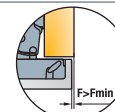

V	16	17	18	19	20	21	22	23	24	25	26
3	0.5	0.7	0.8	1	1.2	1.5	1.7	2.1	2.8	4.1	5.5
4	0.4	0.7	0.8	1	1.2	1.5	1.7	2.1	2.3	3.1	4.5
K											
5	0.4	0.6	0.7	0.9	1.1	1.4	1.6	2	2.2	2.6	3.5
6	0.4	0.6	0.7	0.9	1.1	1.4	1.6	2	2.2	2.6	2.9
											F <sub>MIN</sub>

Gap Z<sub>MIN</sub>=0

# T-type-i 110/15°

15° angled application for wood doors

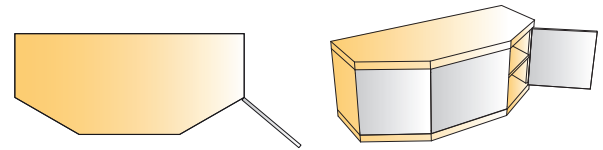
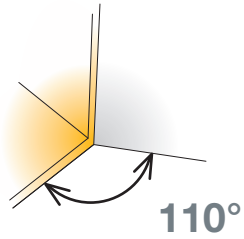

- Opening angle 110°
- Drilling diameter for hinge cup 35mm
- Drilling depth 12mm
- Hinge on plate mounting system 3Way snap-on



Technical details

Cup type	Interaxis 45mm	Interaxis 48mm
Item number	Item number	Item number
Screw-on	701-0D64-650	701-0D66-650
Machine insertion	701-0D70-650	701-0D72-650
EasyFix	701-0D76-650	701-0D78-650

Drilling patterns for hinge cups → see page 2.15

Cranking  
9mm

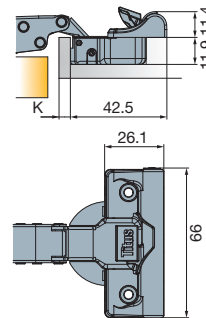
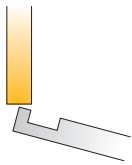

100 Pcs

Cup made of steel, arm made of zinc

Mounting plates  
→ see pages 2.79-2.84



Cover caps for hinge arm  
→ see page 2.173



Hinge cup screws  
If not pre-mounted

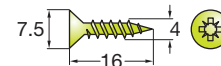

820-6328-050

10000 Pcs

Hinge angle restrictor  
→ see page 2.171



TouchControl solutions  
→ see pages 2.193-2.204



Damping adjustment

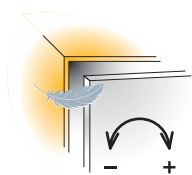

Door adjustment

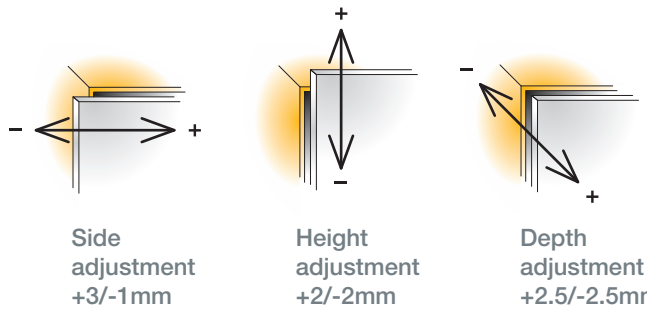

For further explanation → see page 2.23

For further explanation → see pages 2.20-2.22

Mounting details

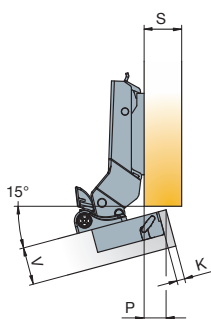
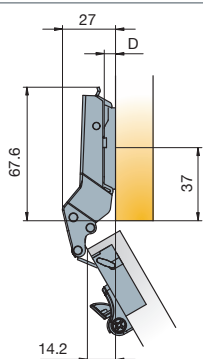

Mounting plate drilling distance

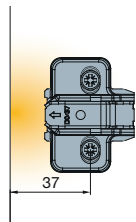

Mounting plate thickness table

For further explanation → see page 2.11

P	11	12	13	14	15	16	17	18
3	4	3	2	1	0			
4		4	3	2	1	0		
5			4	3	2	1	0	
6				4	3	2	1	0

Drawings show application on D=0mm mounting plate

Door clearance at R=1mm

For further explanation → see page 2.12

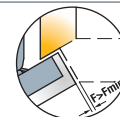

V	16	17	18	19	20	21	22	23	24	25	26
3	0.5	0.7	0.8	1	1.2	1.5	1.7	2.1	2.8	4.1	5.5
4	0.4	0.7	0.8	1	1.2	1.5	1.7	2.1	2.3	3.1	4.5
5	0.4	0.6	0.7	0.9	1.1	1.4	1.6	2	2.2	2.6	3.5
6	0.4	0.6	0.7	0.9	1.1	1.4	1.6	2	2.2	2.6	2.9 F <sub>MIN</sub>

Gap Z<sub>MIN</sub>=0

# T-type-i 110/30°

30° angled application for wood doors

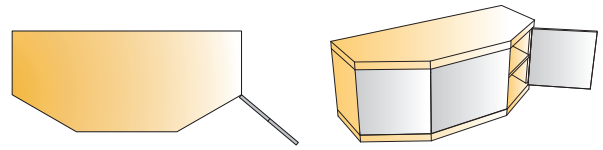
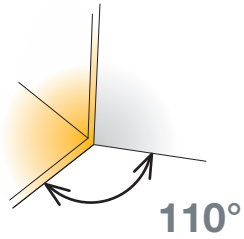

- Opening angle 110°
- Drilling diameter for hinge cup 35mm
- Drilling depth 12mm
- Hinge on plate mounting system 3Way snap-on



Technical details

Cup type	Interaxis 45mm	Interaxis 48mm
Item number	Item number	Item number
Screw-on	701-0E52-650	701-0E54-650
Machine insertion	701-0E58-650	701-0E60-650
EasyFix	701-0E64-650	701-0E66-650

Cranking  
9mm

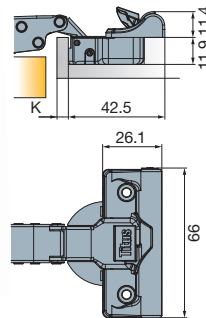
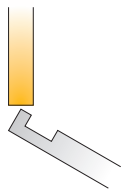

Drilling patterns for hinge cups → see page 2.15

100 Pcs

Cup made of steel, arm made of zinc

Mounting plates  
→ see pages 2.79-2.84



Cover caps for hinge arm  
→ see page 2.173



Hinge cup screws  
If not pre-mounted

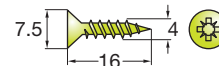

820-6328-050

10000 Pcs

Hinge angle restrictor  
→ see page 2.171



TouchControl solutions  
→ see pages 2.193-2.204



Damping adjustment

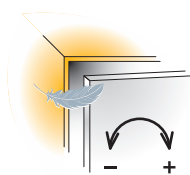

Door adjustment

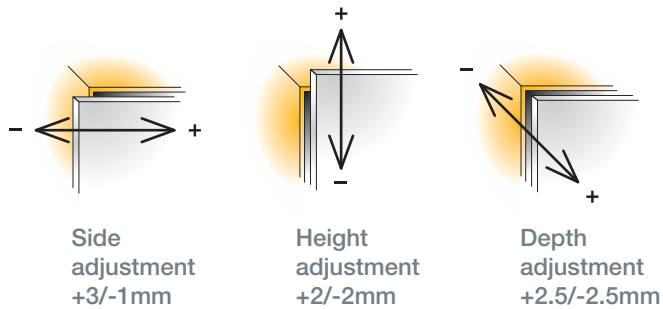

For further explanation → see page 2.23

For further explanation → see pages 2.20-2.22

Mounting details

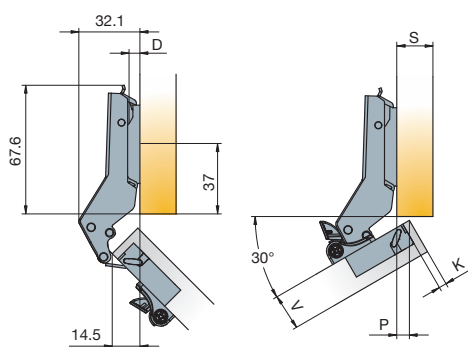

Mounting plate drilling distance

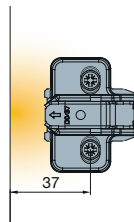

Mounting plate thickness table

For further explanation → see page 2.11

P	1.5	2.5	3.5	4.5	5.5	6.5	7.5	8.5
3	4	3	2	1	0			
4		4	3	2	1	0		
5			4	3	2	1	0	
6				4	3	2	1	0

Drawings show application on D=0mm mounting plate

Door clearance at R=1mm

For further explanation → see page 2.12

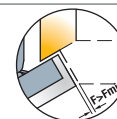

V	16	17	18	19	20	21	22	23	24	25	26
3	0.5	0.7	0.8	1	1.2	1.5	1.7	2.1	2.8	4.1	5.5
4	0.4	0.7	0.8	1	1.2	1.5	1.7	2.1	2.3	3.1	4.5
5	0.4	0.6	0.7	0.9	1.1	1.4	1.6	2	2.2	2.6	3.5
6	0.4	0.6	0.7	0.9	1.1	1.4	1.6	2	2.2	2.6	2.9

Gap Z<sub>MIN</sub>=0

# T-type-i 110/45°

45° angled application for wood doors

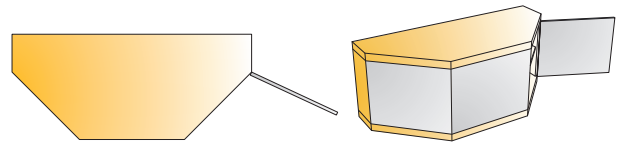
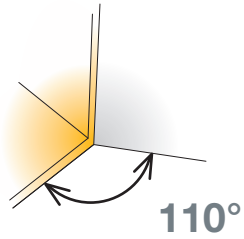

- Opening angle 110°
- Drilling diameter for hinge cup 35mm
- Drilling depth 12mm
- Hinge on plate mounting system 3Way snap-on



Technical details

Cup type	Interaxis 45mm	Interaxis 48mm
Item number		

Cranking 9mm

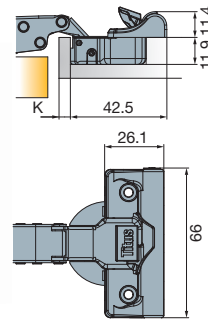
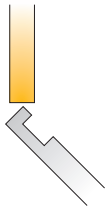

Screw-on	701-0D82-650	701-0D84-650
Machine insertion	701-0D88-650	701-0D90-650
EasyFix	701-0D98-650	701-0E32-650

Drilling patterns for hinge cups → see page 2.15

100 Pcs

Cup made of steel, arm made of zinc

Cranking 17mm

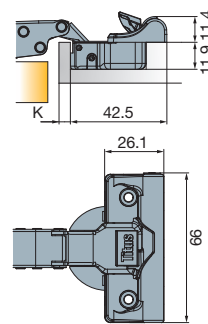
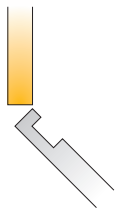

Screw-on	701-0B08-650	701-0B10-650
Machine insertion	701-0C78-650	701-0C80-650
EasyFix	701-0C54-650	701-0C56-650

Drilling patterns for hinge cups → see page 2.15

100 Pcs

Cup made of steel, arm made of zinc

Mounting plates  
→ see pages 2.79-2.84



Cover caps for hinge arm  
→ see page 2.173



Hinge cup screws  
If not pre-mounted

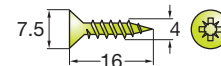

820-6328-050

10000 Pcs

Hinge angle restrictor  
→ see page 2.171



TouchControl solutions  
→ see pages 2.193-2.204



Damping adjustment

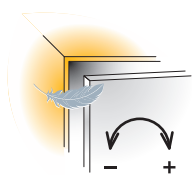

Door adjustment

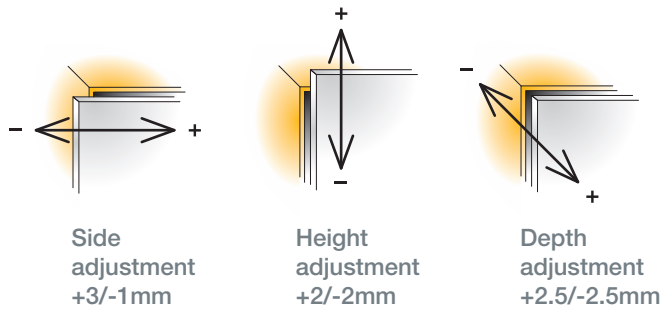

For further explanation → see page 2.23

For further explanation → see pages 2.20-2.22

Mounting details

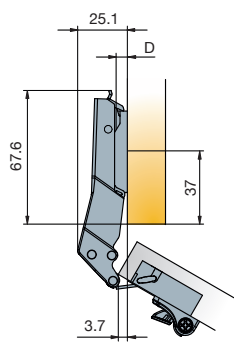

Mounting plate drilling distance

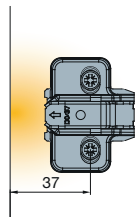
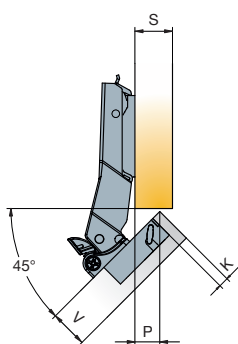

Mounting plate thickness table

For further explanation → see page 2.11

P	7	7.5	8	8.5	9	9.5	10	10.5	11	11.5	12	12.5	13	13.5
3	4		3		2		1		0					
4			4		3		2		1		0			
5				4		3		2		1		0		
6						4		3		2		1		0

Drawings show application on D=0mm mounting plate

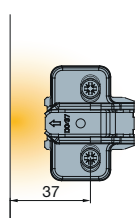
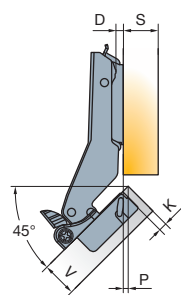
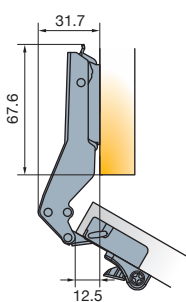

P	0	0.5	1	1.5	2	2.5	3	3.5	4
3		2		1		0			
4	3		2		1		0		
5		3		2		1		0	
6	4		3		2		1		0 D

Drawings show application on D=0mm mounting plate

Door clearance at R=1mm

For further explanation → see page 2.12

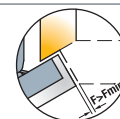

V	16	17	18	19	20	21	22	23	24	25	26
3	0.5	0.7	0.8	1	1.2	1.5	1.7	2.1	2.8	4.1	5.5
4	0.4	0.7	0.8	1	1.2	1.5	1.7	2.1	2.3	3.1	4.5
5	0.4	0.6	0.7	0.9	1.1	1.4	1.6	2	2.2	2.6	3.5
6	0.4	0.6	0.7	0.9	1.1	1.4	1.6	2	2.2	2.6	2.9 F <sub>MIN</sub>

Gap Z<sub>MIN</sub>=0

# T-type-i 110/45°

45° angled application for wood doors

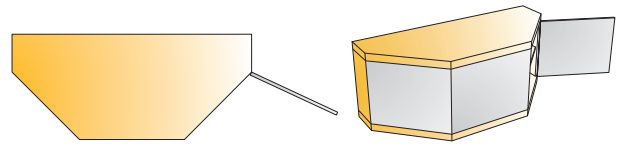
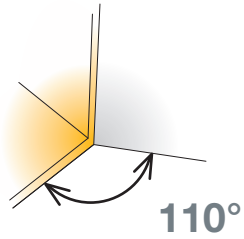

- Opening angle 110°
- Drilling diameter for hinge cup 35mm
- Drilling depth 12mm
- Hinge on plate mounting system 3Way snap-on



Technical details

Cup type	Interaxis 45mm	Interaxis 48mm
Item number	Item number	Item number
Screw-on	701-0W59-650	701-0W60-650
Machine insertion	701-0W62-650	701-0W63-650
EasyFix	701-0W65-650	701-0W66-650

Drilling patterns for hinge cups → see page 2.15

Cranking  
23mm

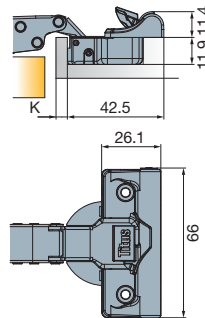
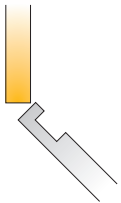

100 Pcs

Cup made of steel, arm made of zinc

Mounting plates  
→ see pages 2.79-2.84



Cover caps for hinge arm  
→ see page 2.173



Hinge cup screws  
If not pre-mounted

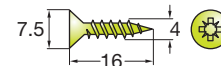

820-6328-050

10000 Pcs

Hinge angle restrictor  
→ see page 2.171



TouchControl solutions  
→ see pages 2.193-2.204



Damping adjustment

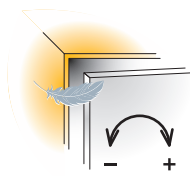

Door adjustment

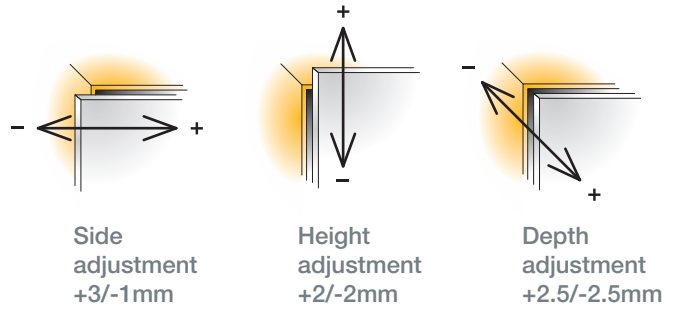

For further explanation → see page 2.23

For further explanation → see pages 2.20-2.22

Mounting details

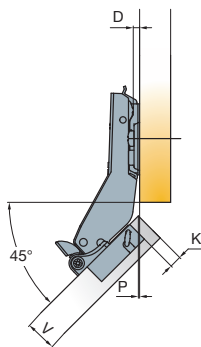
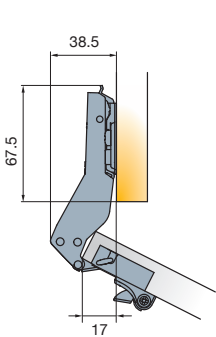

Mounting plate drilling distance

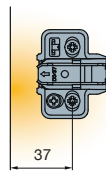

Mounting plate thickness table

For further explanation → see page 2.11

P	7.5	7	6.5	6	5.5	5	4.5	4	3.5	3	2.5	2	1.5
3	4		3		2		1		0				
4		4		3		2		1		0			
5				4		3		2		1		0	
6					4		3		2		1		0

Door clearance at R=1mm

For further explanation → see page 2.12



V	16	17	18	19	20	21	22	23	24	25	26
3	0.5	0.7	0.8	1	1.2	1.5	1.7	2.1	2.8	4.1	5.5
4	0.4	0.7	0.8	1	1.2	1.5	1.7	2.1	2.3	3.1	4.5
5	0.4	0.6	0.7	0.9	1.1	1.4	1.6	2	2.2	2.6	3.5
6	0.4	0.6	0.7	0.9	1.1	1.4	1.6	2	2.2	2.6	2.9 F <sub>MIN</sub>

Gap Z<sub>MIN</sub>=0

# T-type-i 110/90°

For wood door cabinets with blind panels

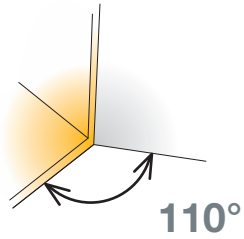
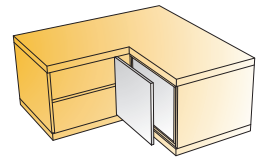

- Opening angle 110°
- Drilling diameter for hinge cup 35mm
- Drilling depth 12mm
- Hinge on plate mounting system 3Way snap-on



Technical details

Cup type	Interaxis 45mm	Interaxis 48mm
	Item number	Item number
	701-0A96-650	701-0A98-650
	701-0D36-650	701-0D38-650
	701-0D30-650	701-0D32-650

Cranking  
17mm

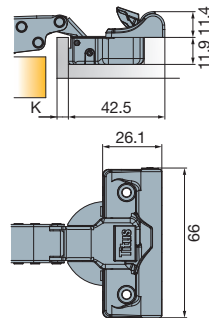
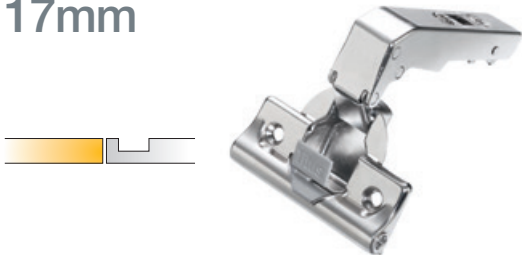

Drilling patterns for hinge cups → see page 2.15

100 Pcs

Cup made of steel, arm made of zinc

Mounting plates  
→ see pages 2.79-2.84



Cover caps for hinge arm  
→ see page 2.173



Hinge cup screws  
If not pre-mounted

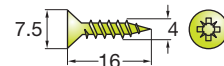

820-6328-050

10000 Pcs

Hinge angle restrictor  
→ see page 2.171



TouchControl solutions  
→ see pages 2.193-2.204



· We advise combining with a D=2mm mounting plate.

Damping adjustment

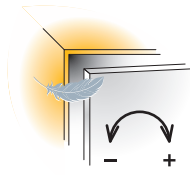

Door adjustment

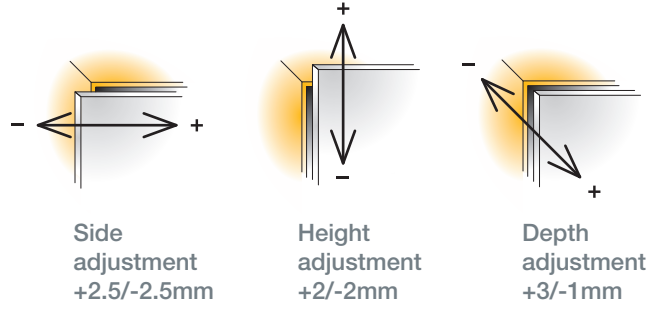

Side adjustment  
+2.5/-2.5mm

Height adjustment  
+2/-2mm

Depth adjustment  
+3/-1mm

For further explanation → see page 2.23

For further explanation → see pages 2.20-2.22

Mounting details

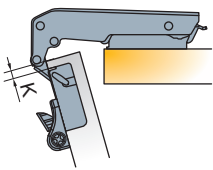

Mounting plate drilling distance

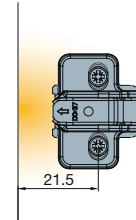
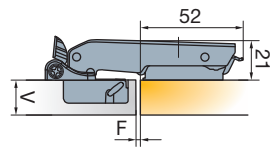

Drawing shows application on D=2mm mounting plate

Door clearance at R=1mm

For further explanation → see page 2.12

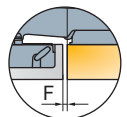

V	16	17	18	19	20	21	22	23	24	25	26
3	0.5	0.7	0.8	1	1.2	1.5	1.7	2.1	2.8	4.1	5.5
4	0.4	0.7	0.8	1	1.2	1.5	1.7	2.1	2.3	3.1	4.5
K											
5	0.4	0.6	0.7	0.9	1.1	1.4	1.6	2	2.2	2.6	3.5
6	0.4	0.6	0.7	0.9	1.1	1.4	1.6	2	2.2	2.6	2.9 F <sub>MIN</sub>

Gap Z<sub>MIN</sub>=0

# T-type-i 120

For wood doors

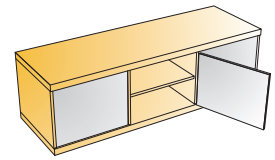
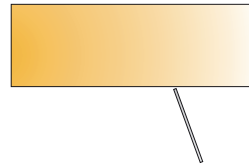
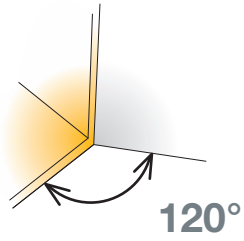

- Opening angle
- Drilling diameter for hinge cup
- Drilling depth
- Hinge on plate mounting system

- 120°
- 35mm
- 12mm
- 3Way snap-on



Technical details

Cup type	Interaxis 45mm	Interaxis 48mm
Item number	Item number	Item number
Screw-on	701-OUT0-054	701-0US0-054
Machine insertion	701-OUT1-054	701-0US1-054
EasyFix	701-OUT4-054	701-0US4-054

Drilling patterns for hinge cups → see page 2.15

Cranking  
0mm

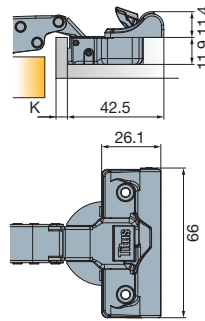

150 Pcs

Made of steel

Mounting plates  
→ see pages 2.79-2.84



Cover caps for hinge arm  
→ see page 2.173



Hinge cup screws  
If not pre-mounted

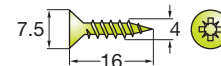

820-6328-050

10000 Pcs

TouchControl solutions  
→ see pages 2.193-2.204



Damping adjustment

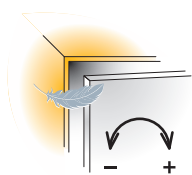

Door adjustment

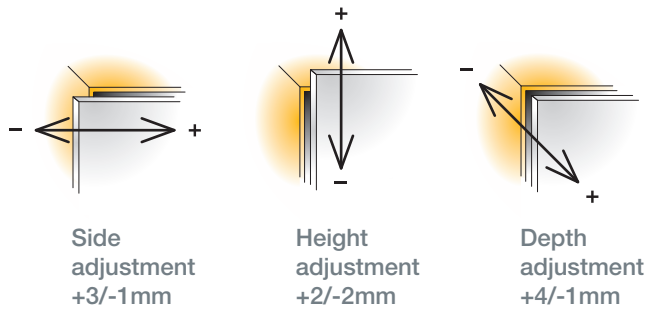

For further explanation → see page 2.23

For further explanation → see pages 2.20-2.22

Mounting details

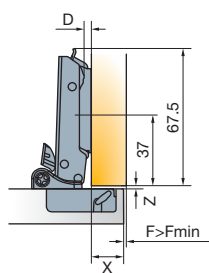
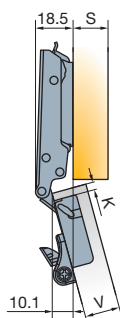

Mounting plate drilling distance

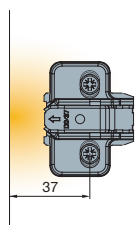

Mounting plate thickness table

For further explanation → see page 2.11

X	13	14	15	16	17	18	19
3	3	2	1	0			
4	4	3	2	1	0		
K							
5		4	3	2	1	0	
6			4	3	2	1	0

$D=13+K-X$

Drawings show application on D=0mm mounting plate

Door clearance at R=1mm

For further explanation → see page 2.12

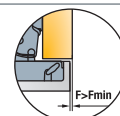

V	16	17	18	19
3	1.1	0.4	0	0
K				
4	2	1.4	0.7	0.1
5	3	2.3	1.6	1

Gap Z<sub>MIN</sub> = 2

# T-type-i 95 Thick Door Hinge

For wood doors

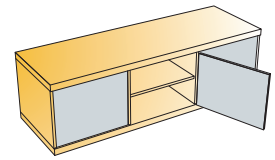
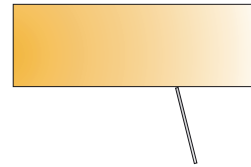
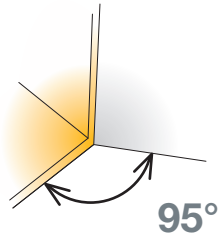

- Opening angle
- Drilling diameter for hinge cup
- Drilling depth
- Hinge on plate mounting system

95°  
35mm  
12mm  
3Way snap-on



Technical details

Cup type	Interaxis 45mm	Interaxis 48mm
Item number	Item number	Item number
Screw-on	708-0XT0-054	708-0XS0-054
Machine insertion	708-0XT1-054	708-0XS1-054
EasyFix	708-0XT4-054	708-0XS4-054
Drilling patterns for hinge cups → see page 2.15		

Cranking  
0mm

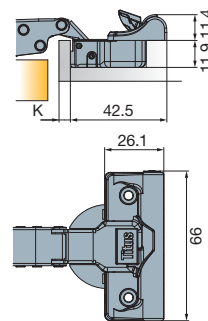

150 Pcs Made of steel

Cranking  
5mm

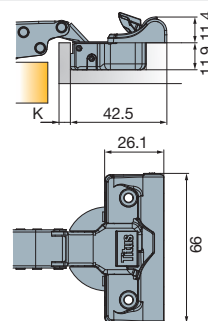
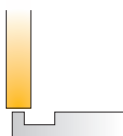

150 Pcs Made of steel

Screw-on	708-0YT0-054	708-0YS0-054
Machine insertion	708-0YT1-054	708-0YS1-054
EasyFix	708-0YT4-054	708-0YS4-054
Drilling patterns for hinge cups → see page 2.15		

Mounting plates  
→ see pages 2.79-2.84



Cover caps for hinge arm  
→ see page 2.173



Hinge cup screws  
If not pre-mounted

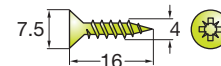

820-6328-050  
10000 Pcs

TouchControl solutions  
→ see pages 2.193-2.204



Damping adjustment

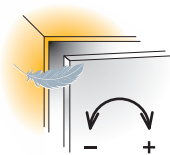

Door adjustment

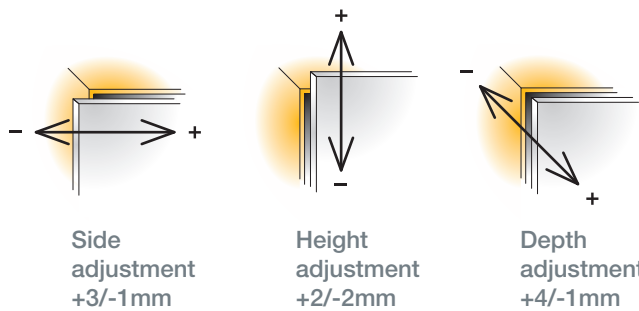

For further explanation → see page 2.23

For further explanation → see pages 2.20-2.22

Mounting details

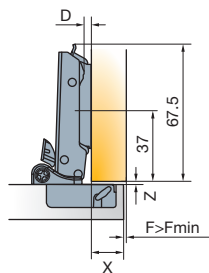
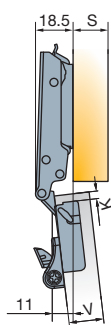

Mounting plate drilling distance

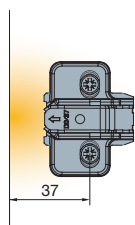

Mounting plate thickness table

For further explanation → see page 2.11

X	13	14	15	16	17	18	19	20	21	22
3	3	2	1	0						
4	4	3	2	1	0					
5		4	3	2	1	0				
K 6			4	3	2	1	0			
7				4	3	2	1	0		
8					4	3	2	1	0	
9						4	3	2	1	0

$D=13+K-X$

Drawings show application on D=0mm mounting plate

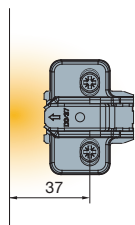
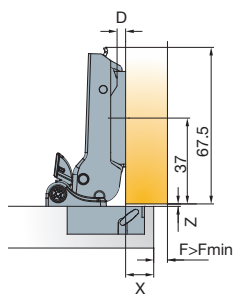
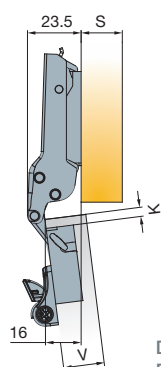

X	8	9	10	11	12	13	14	15	16	17
3	3	2	1	0						
4	4	3	2	1	0					
5		4	3	2	1	0				
K 6			4	3	2	1	0			
7				4	3	2	1	0		
8					4	3	2	1	0	
9						4	3	2	1	0

$D=8+K-X$

Drawings show application on D=0mm mounting plate

Gap Z

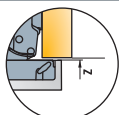

V	20	22	24	26	28	30	32	34	
3	0	0	0	0	0	0	0	0	
4	0	0	0	0	0	0	0	0	
5	0	0	0	0	0	0	0	0	
K 6	0	0	0	0	0	0	0	0	
7	0	0	0	0	0	0	0	0	
8	0	0	0	0	0	0	0	0	
9	0	0	1.6	1.7	1.8	2.0	2.1	2.3	Z <sub>MIN</sub>

Door clearance at R=1mm

For further explanation → see page 2.12



V	20	22	24	26	28	30	32	34	
3	0.6	0.9	1.3	1.7	2.2	4.0	5.9	7.8	
4	0.6	0.9	1.2	1.7	2.2	3.4	5.2	7.1	
5	0.6	0.9	1.2	1.6	2.1	2.9	4.6	6.5	
K 6	0.6	0.9	1.2	1.5	2.1	2.6	4.1	5.9	
7	0.6	0.9	1.2	1.5	2.1	2.6	3.6	5.3	
8	0.6	0.8	1.2	1.5	2.0	2.5	3.2	4.8	
9	0.6	0.8	1.2	1.5	2.0	2.5	3.1	4.4	F <sub>MIN</sub>

# T-type-i 95 Thick Door Hinge

For wood doors

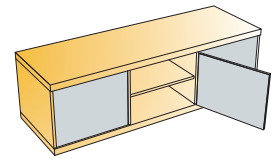
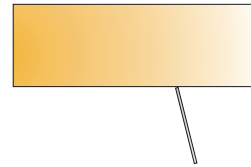
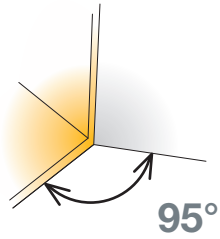

- Opening angle
- Drilling diameter for hinge cup
- Drilling depth
- Hinge on plate mounting system

95°  
35mm  
12mm  
3Way snap-on



Technical details

Cup type	Interaxis 45mm	Interaxis 48mm
	Item number	Item number
	708-0ZT0-054	708-0ZS0-054
	708-0ZT1-054	708-0ZS1-054
	708-0ZT4-054	708-0ZS4-054
Drilling patterns for hinge cups → see page 2.15		

Cranking  
9mm

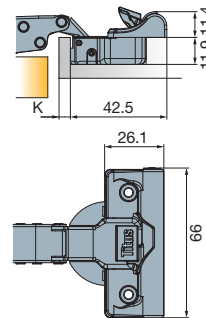
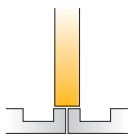

150 Pcs

Made of steel

Cranking  
17mm

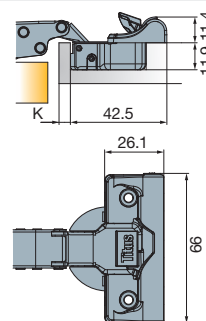
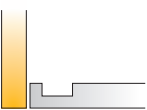

150 Pcs

Made of steel

	708-0WT0-054	708-0WS0-054
	708-0WT1-054	708-0WS1-054
	708-0WT4-054	708-0WS4-054
Drilling patterns for hinge cups → see page 2.15		

Mounting plates  
→ see pages 2.79-2.84



Cover caps for hinge arm  
→ see page 2.173



Hinge cup screws  
If not pre-mounted

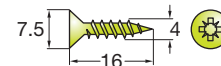

820-6328-050  
10000 Pcs

TouchControl solutions  
→ see pages 2.193-2.204



Damping adjustment

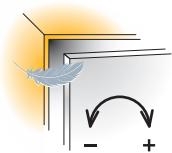

Door adjustment

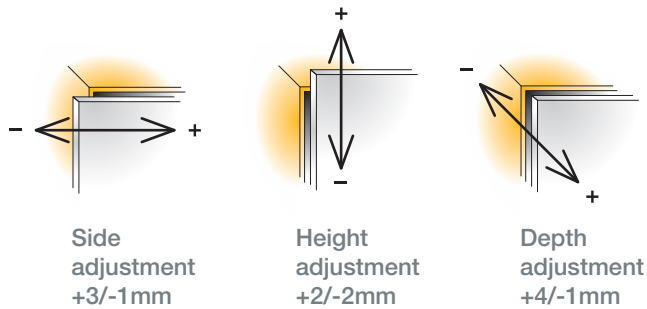

Side adjustment  
+3/-1mm

Height adjustment  
+2/-2mm

Depth adjustment  
+4/-1mm

For further explanation → see page 2.23

For further explanation → see pages 2.20-2.22

Mounting details

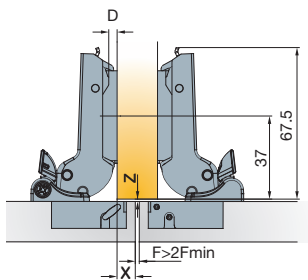
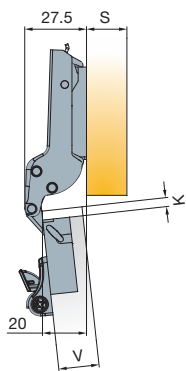

Mounting plate drilling distance

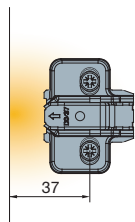

Mounting plate thickness table

For further explanation → see page 2.11

X	4	5	6	7	8	9	10	11	12	13
3	3	2	1	0						
4	4	3	2	1	0					
5		4	3	2	1	0				
K 6			4	3	2	1	0			
7				4	3	2	1	0		
8					4	3	2	1	0	
9						4	3	2	1	0

$D=4+K-X$

Drawings show application on D=0mm mounting plate

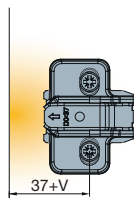
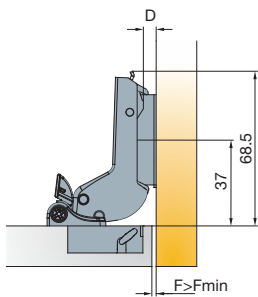
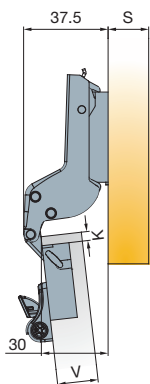

V	20	22	24	26	28	30	32
3	0	0	1	1	2	3	4*
4	1	1	2	2	3	4	4*
K 5	2	2	3	3	4	4	4*
6	3	3	4	4	4*	4*	
7	4	4	4*	4*	4*	4*	

$D=-4+K+F$

\*Hinge adjustment needed

Drawings show application on D=2mm mounting plate

Gap Z

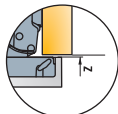

V	20	22	24	26	28	30	32	34
3	0	0	0	0	0	0	0	0
4	0	0	0	0	0	0	0	0
5	0	0	0	0	0	0	0	0
K 6	0	0	0	0	0	0	0	0
7	0	0	0	0	0	0	0	0
8	0	0	0	0	0	0	0	0
9	0	0	1.6	1.7	1.8	2.0	2.1	2.3

**Z<sub>MIN</sub>**

Door clearance at R=1mm

For further explanation → see page 2.12

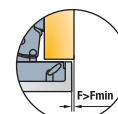

V	20	22	24	26	28	30	32	34
3	0.6	0.9	1.3	1.7	2.2	4.0	5.9	7.8
4	0.6	0.9	1.2	1.7	2.2	3.4	5.2	7.1
5	0.6	0.9	1.2	1.6	2.1	2.9	4.6	6.5
K 6	0.6	0.9	1.2	1.5	2.1	2.6	4.1	5.9
7	0.6	0.9	1.2	1.5	2.1	2.6	3.6	5.3
8	0.6	0.8	1.2	1.5	2.0	2.5	3.2	4.8
9	0.6	0.8	1.2	1.5	2.0	2.5	3.1	4.4

**F<sub>MIN</sub>**

# T-type-i 170

For wood doors

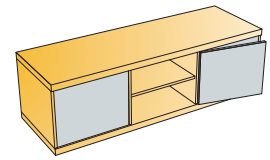
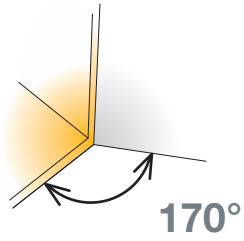

- Opening angle
- Drilling diameter for hinge cup
- Drilling depth
- Hinge on plate mounting system

- 165°
- 35mm
- 12mm,
- 12.5mm PressTo
- 3Way snap-on

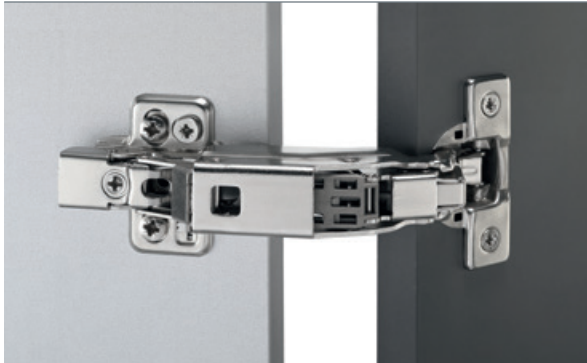

Technical details

Cup type	Interaxis 45mm	Interaxis 48mm
Item number		

Cranking  
0mm

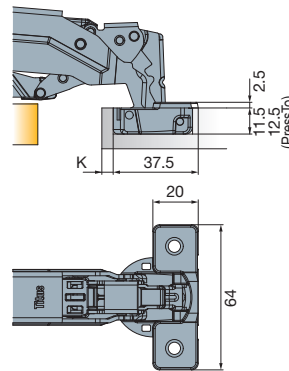

Screw-on	701-0ET0-054	701-0ES0-054
Machine insertion	701-0ET1-054	701-0ES1-054
EasyFix	701-0ET4-054	701-0ES4-054
PressTo	701-0ET6-054	

Drilling patterns for hinge cups → see page 2.15

50 Pcs

Made of steel and zinc

Mounting plates  
→ see pages 2.79-2.84



Hinge cup screws  
If not pre-mounted

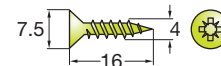

820-6328-050

10000 Pcs

Hinge angle restrictor  
→ see page 2.171



TouchControl solutions  
→ see pages 2.193-2.204



Zero protrusion  
with D=0 mounting plate

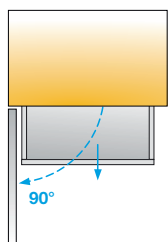

Door adjustment

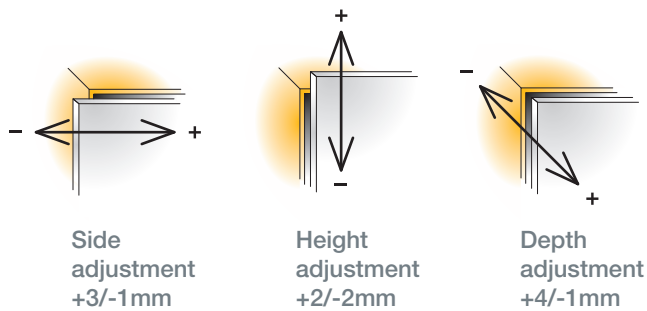

For further explanation → see pages 2.20-2.22

Mounting details

Mounting plate drilling distance

Mounting plate thickness table  
For further explanation → see page 2.11

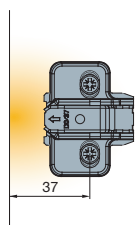
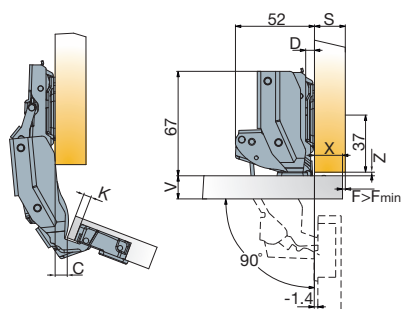

Drawings show application on  
D=0mm mounting plate  
No door protrusion in  
90° position

X	13	14	15	16	17	18	19	20
3	3	2	1	0				
4	4	3	2	1	0			
5		4	3	2	1	0		
6			4	3	2	1	0	
7				4	3	2	1	0

$D=13+K-X$

C value with D=0 mounting plate

K	3	4	5	6	7	C
	-9.0	-8.1	-7.1	-6.1	-5.2	

Door clearance at R=1mm  
For further explanation → see page 2.12

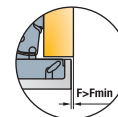

V	16	17	18	19	20	21	22	23	24
3	0.0	0.0	0.0	0.0	0.0	0.0	0.0	0.0	0.0
4	0.0	0.0	0.0	0.0	0.0	0.0	0.0	0.0	0.0
K 5	0.0	0.0	0.0	0.0	0.0	0.0	0.0	0.0	0.0
6	0.0	0.0	0.0	0.0	0.0	0.0	0.0	0.0	2.6
7	0.0	0.0	0.0	0.0	0.0	0.0	0.0	0.0	5.1

Gap  $Z_{MIN}=0.5$

# T-type-i 170

For wood doors

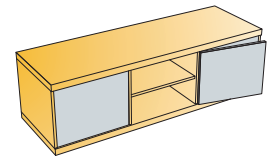
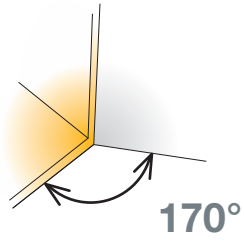

- Opening angle
- Drilling diameter for hinge cup
- Drilling depth
- Hinge on plate mounting system

165°  
35mm  
12mm,  
12.5mm PressTo  
3Way snap-on



Technical details

Cup type	Interaxis 45mm	Interaxis 48mm
	Item number	Item number
	701-0FT0-054	701-0FS0-054
	701-0FT1-054	701-0FS1-054
	701-0FT4-054	701-0FS4-054
	701-0FT6-054	
Drilling patterns for hinge cups → see page 2.15		

Cranking  
5mm

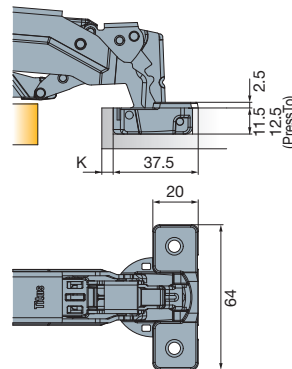

50 Pcs

Made of steel and zinc

Cranking  
9mm

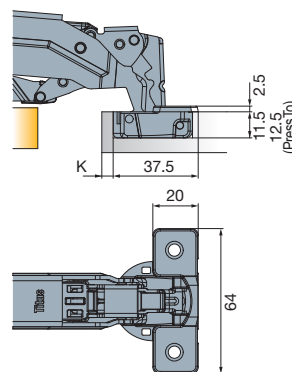
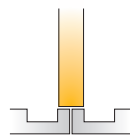

50 Pcs

Made of steel and zinc

	701-0GT0-054	701-0GS0-054
	701-0GT1-054	701-0GS1-054
	701-0GT4-054	701-0GS4-054
	701-0GT6-054	
Drilling patterns for hinge cups → see page 2.15		

Mounting plates

→ see pages 2.79-2.84



Hinge cup screws

If not pre-mounted

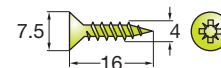

820-6328-050

10000 Pcs

Hinge angle restrictor

→ see page 2.171



TouchControl solutions

→ see pages 2.193-2.204



Zero protrusion  
with D=0 mounting plate

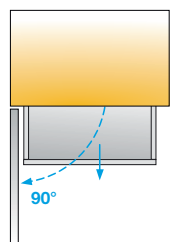

Door adjustment

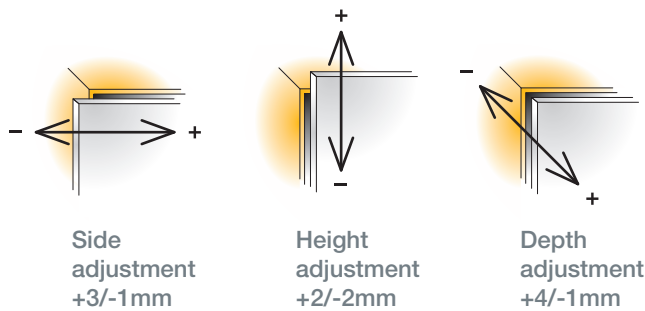

For further explanation → see pages 2.20-2.22

Mounting details

Mounting plate drilling distance

Mounting plate thickness table

For further explanation → see page 2.11

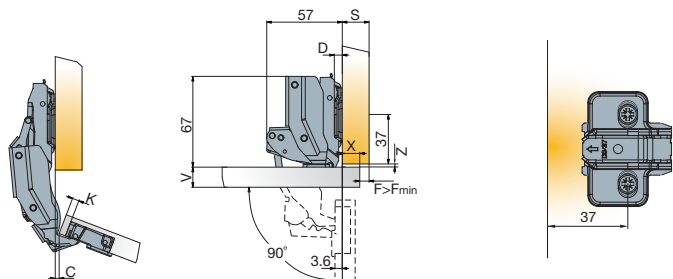

Drawings show application on  
D=0mm mounting plate

X	8	9	10	11	12	13	14
3	3	2	1	0			
4	4	3	2	1	0		
K 5		4	3	2	1	0	
6			4	3	2	1	0
							D

$D=8+K-X$

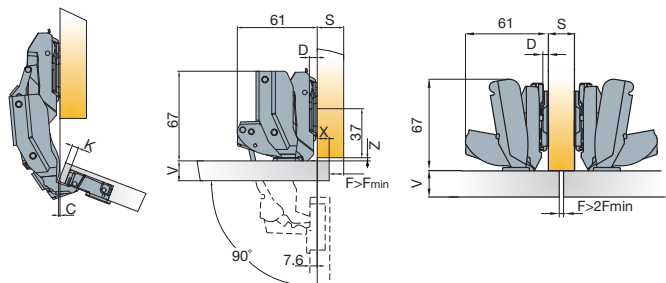

Drawings show application on  
D=0mm mounting plate

Drawing show application on  
D=0mm mounting plate

X	1	2	3	4	5	6	7	8	9	10	11
3	6			3	2	1	0				
4		6			3	2	1	0			
K 5			6			3	2	1	0		
6				6			3	2	1	0	
7					6			3	2	1	0
											D

$D=4+K-X$

Door clearance at R=1mm

For further explanation → see page 2.12

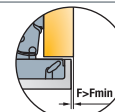

V	16	17	18	19	20	21	22	23	24
3	0.0	0.0	0.0	0.0	0.0	0.0	0.0	0.0	0.0
4	0.0	0.0	0.0	0.0	0.0	0.0	0.0	0.0	0.0
K 5	0.0	0.0	0.0	0.0	0.0	0.0	0.0	0.0	0.0
6	0.0	0.0	0.0	0.0	0.0	0.0	0.0	0.0	2.6
7	0.0	0.0	0.0	0.0	0.0	0.0	0.0	0.0	5.1

Gap  $Z_{MIN}=0.5$

# T-type 110

For wood doors

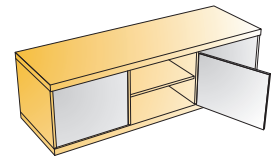
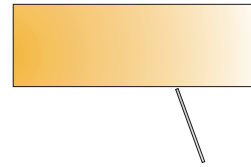
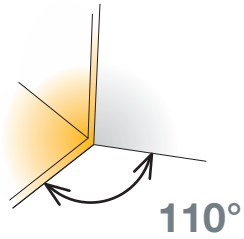

- Opening angle
- Drilling diameter for hinge cup
- Drilling depth
- Hinge on plate mounting system

110°  
35mm  
12mm  
3Way snap-on



Technical details

Cup type	Interaxis 45mm	Interaxis 48mm
Item number	Item number	Item number
Screw-on	702-0AK0-054	702-0AL0-054
Machine insertion	702-0AK1-054	702-0AL1-054
EasyFix	702-0AK4-054	702-0AL4-054
<p><b>i</b> Technical and drilling details → see page 2.15</p>		

Cranking  
0mm

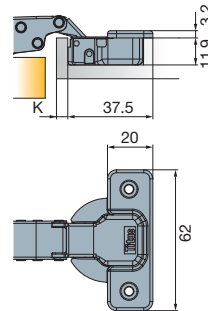

150 Pcs

Made of steel

Cranking  
5mm

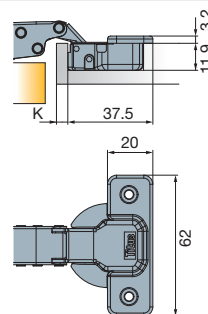

150 Pcs

Made of steel

Screw-on	702-0BK0-054	702-0BL0-054
Machine insertion	702-0BK1-054	702-0BL1-054
EasyFix	702-0BK4-054	702-0BL4-054
<p>Drilling patterns for hinge cups → see page 2.15</p>		

Mounting plates  
→ see pages 2.79-2.84



Cover caps for hinge arm  
→ see page 2.173



Hinge cup screws  
If not pre-mounted

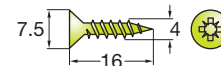

820-6328-050  
10000 Pcs

Hinge angle restrictor  
→ see page 2.171



TouchControl solutions  
→ see pages 2.193-2.204



Soft closing systems  
→ see pages 2.183-2.190



Door adjustment

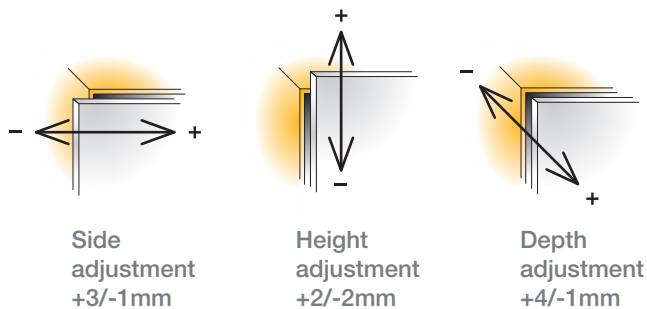

For further explanation → see pages 2.20-2.22

Mounting details

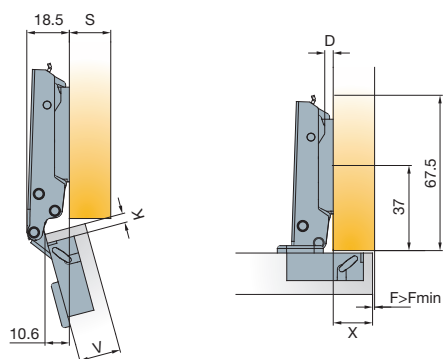

Drawings show application on D=0mm mounting plate

Mounting plate drilling distance

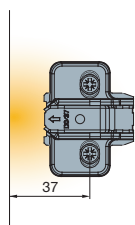

Mounting plate thickness table

For further explanation → see page 2.11

X	13	14	15	16	17	18	19
3	3	2	1	0			
4	4	3	2	1	0		
K							
5		4	3	2	1	0	
6			4	3	2	1	0
							D

$D=13+K-X$

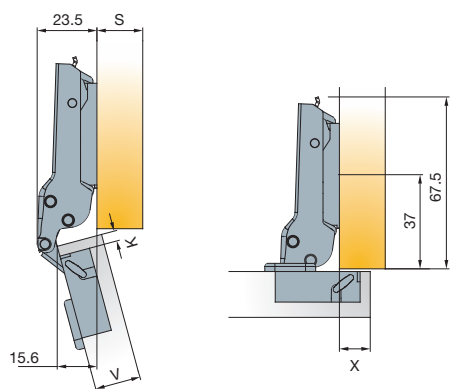

Drawings show application on D=0mm mounting plate

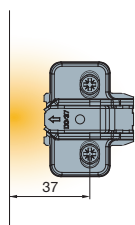

x	8	9	10	11	12	13	14
3	3	2	1	0			
4	4	3	2	1	0		
K							
5		4	3	2	1	0	
6			4	3	2	1	0
							D

$D=8+K-X$

Door clearance at R=1mm

For further explanation → see page 2.12

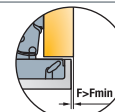

V	16	17	18	19	20	21	22	23	24	25	26
3	0.5	0.7	0.8	1	1.2	1.5	1.7	2.1	2.8	4.1	5.5
4	0.4	0.7	0.8	1	1.2	1.5	1.7	2.1	2.3	3.1	4.5
K											
5	0.4	0.6	0.7	0.9	1.1	1.4	1.6	2	2.2	2.6	3.5
6	0.4	0.6	0.7	0.9	1.1	1.4	1.6	2	2.2	2.6	2.9
											F <sub>MIN</sub>

Gap Z<sub>MIN</sub>=0

# T-type 110

For wood doors

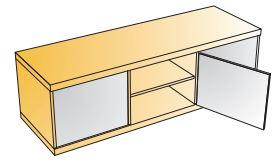
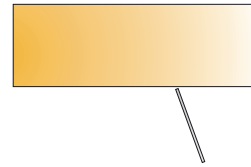
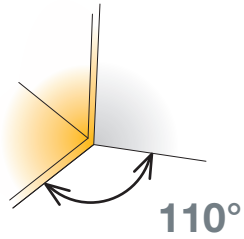

- Opening angle
- Drilling diameter for hinge cup
- Drilling depth
- Hinge on plate mounting system

110°  
35mm  
12mm  
3Way snap-on



Technical details

Cup type	Interaxis 45mm	Interaxis 48mm
Item number	Item number	Item number
Screw-on	702-0CK0-054	702-0CL0-054
Machine insertion	702-0CK1-054	702-0CL1-054
EasyFix	702-0CK4-054	702-0CL4-054
Drilling patterns for hinge cups → see page 2.15		

Cranking  
9mm

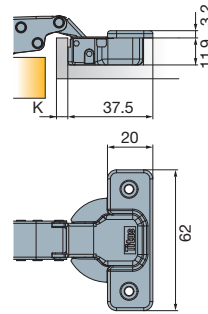
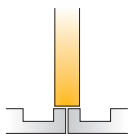

150 Pcs

Made of steel

Cranking  
17mm

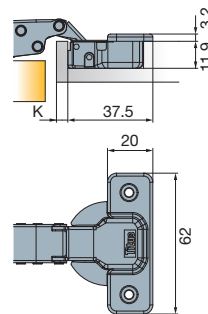
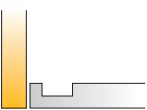

150 Pcs

Made of steel

Screw-on	702-0DK0-054	702-0DL0-054
Machine insertion	702-0DK1-054	702-0DL1-054
EasyFix	702-0DK4-054	702-0DL4-054
Drilling patterns for hinge cups → see page 2.15		

Mounting plates  
→ see pages 2.79-2.84



Cover caps for hinge arm  
→ see page 2.173



Hinge cup screws  
If not pre-mounted

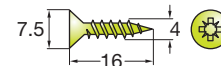

820-6328-050  
10000 Pcs

Hinge angle restrictor  
→ see page 2.171



TouchControl solutions  
→ see pages 2.193-2.204



Soft closing systems  
→ see pages 2.183-2.190



Door adjustment

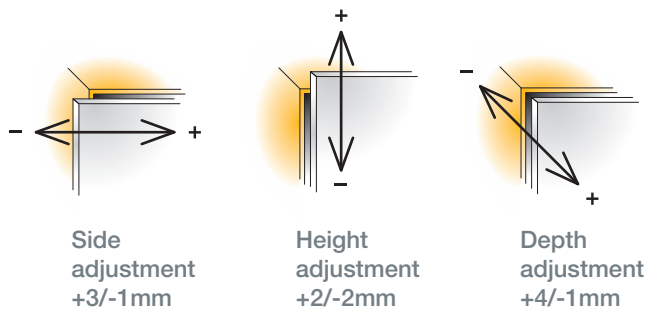

For further explanation → see pages 2.20-2.22

Mounting details

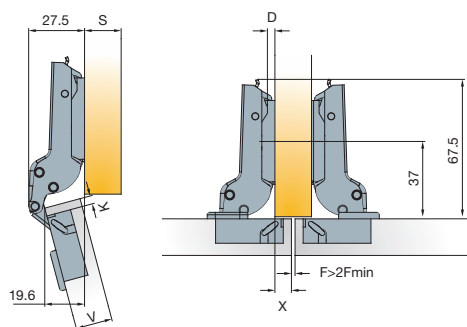

Drawings show application on D=0mm mounting plate

Mounting plate drilling distance

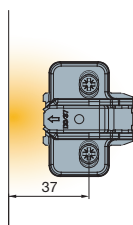

Mounting plate thickness table

For further explanation → see page 2.11

X	4	5	6	7	8	9	10
3	3	2	1	0			
4	4	3	2	1	0		
K							
5		4	3	2	1	0	
6			4	3	2	1	0
							D

$D=4+K-X$

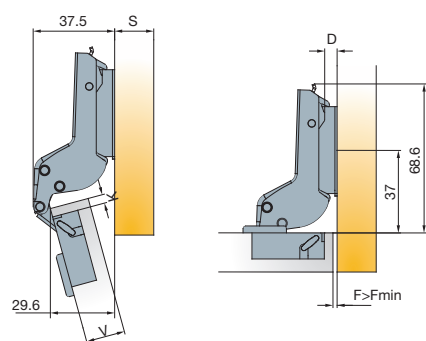

Drawings show application on D=2mm mounting plate

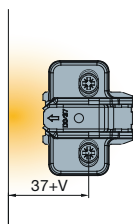

V	16	17	18	19	20	21	22	23	24
3	0	0	0	0	1	1	1	1	2
4	1	1	1	1	2	2	2	2	3
K									
5	2	2	2	2	3	3	3	3	4
6	3	3	3	3	4	4	4	4	
									D

$D=-4+K+F$

Door clearance at R=1mm

For further explanation → see page 2.12

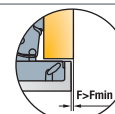

V	16	17	18	19	20	21	22	23	24	25	26
3	0.5	0.7	0.8	1	1.2	1.5	1.7	2.1	2.8	4.1	5.5
4	0.4	0.7	0.8	1	1.2	1.5	1.7	2.1	2.3	3.1	4.5
K											
5	0.4	0.6	0.7	0.9	1.1	1.4	1.6	2	2.2	2.6	3.5
6	0.4	0.6	0.7	0.9	1.1	1.4	1.6	2	2.2	2.6	2.9
											F <sub>MIN</sub>

Gap Z<sub>MIN</sub>=0

# T-type 110/15°

15° angled application for wood doors

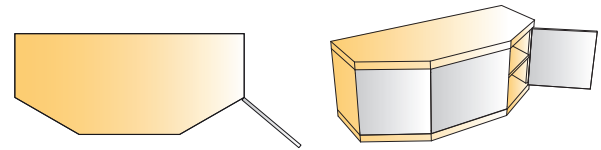
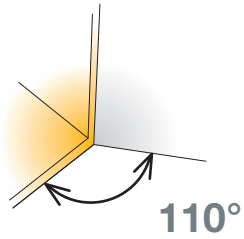

- Opening angle 110°
- Drilling diameter for hinge cup 35mm
- Drilling depth 12mm
- Hinge on plate mounting system 3Way snap-on



Technical details

Cup type	Interaxis 45mm	Interaxis 48mm
	Item number	Item number
	702-0D63-650	702-0D65-650
	702-0D69-650	702-0D71-650
	702-0D75-650	702-0D77-650

Drilling patterns for hinge cups → see page 2.15

Cranking  
9mm

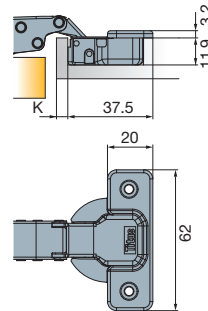
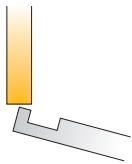

100 Pcs

Cup made of steel, arm made of zinc

Mounting plates  
→ see pages 2.79-2.84



Cover caps for hinge arm  
→ see page 2.173



Hinge cup screws  
If not pre-mounted

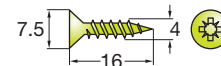

820-6328-050

10000 Pcs

Hinge angle restrictor  
→ see page 2.171



TouchControl solutions  
→ see pages 2.193-2.204



Soft closing systems  
→ see pages 2.183-2.190



Door adjustment

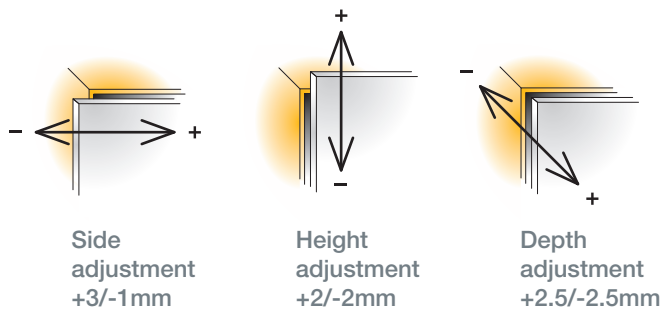

For further explanation → see pages 2.20-2.22

Mounting details

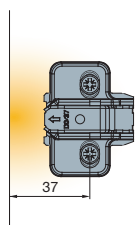
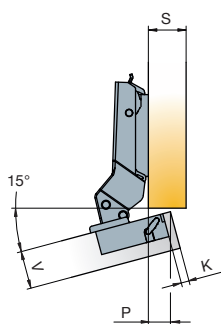
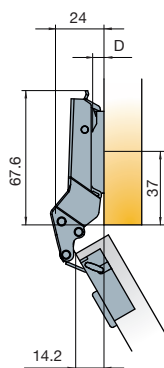

Mounting plate drilling distance

Mounting plate thickness table

For further explanation → see page 2.11

P	11	12	13	14	15	19	17	18	
3	4	3	2	1	0				
4		4	3	2	1	0			
K	5		4	3	2	1	0		
6				4	3	2	1	0	D

Drawings show application on D=0mm mounting plate

Door clearance at R=1mm

For further explanation → see page 2.12

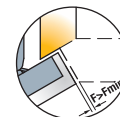

V	16	17	18	19	20	21	22	23	24	25	26	
3	0.5	0.7	0.8	1	1.2	1.5	1.7	2.1	2.8	4.1	5.5	
4	0.4	0.7	0.8	1	1.2	1.5	1.7	2.1	2.3	3.1	4.5	
K	5	0.4	0.6	0.7	0.9	1.1	1.4	1.6	2	2.2	2.6	3.5
6	0.4	0.6	0.7	0.9	1.1	1.4	1.6	2	2.2	2.6	2.9	F <sub>MIN</sub>

Gap Z<sub>MIN</sub>=0

# T-type 110/30°

30° angled application for wood doors

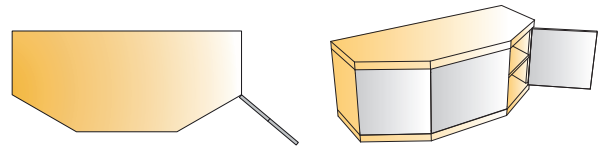
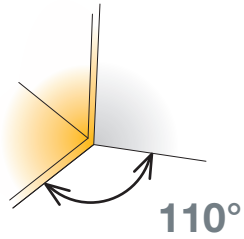

- Opening angle
  - Drilling diameter for hinge cup
  - Drilling depth
  - Hinge on plate mounting system
- 110°  
35mm  
12mm  
3Way snap-on



Technical details

Cup type	Interaxis 45mm	Interaxis 48mm
	Item number	Item number
	702-0E51-650	702-0E53-650
	702-0E57-650	702-0E59-650
	702-0E63-650	702-0E65-650

Drilling patterns for hinge cups → see page 2.15

Cranking  
9mm

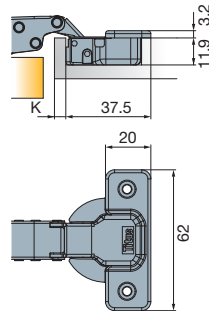
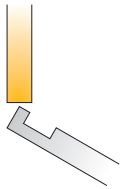

100 Pcs

Cup made of steel, arm made of zinc

Mounting plates  
→ see pages 2.79-2.84



Cover caps for hinge arm  
→ see page 2.173



Hinge cup screws  
If not pre-mounted

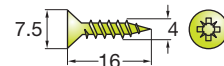

820-6328-050

10000 Pcs

Hinge angle restrictor  
→ see page 2.171



TouchControl solutions  
→ see pages 2.193-2.204



Soft closing systems  
→ see pages 2.183-2.190



Door adjustment

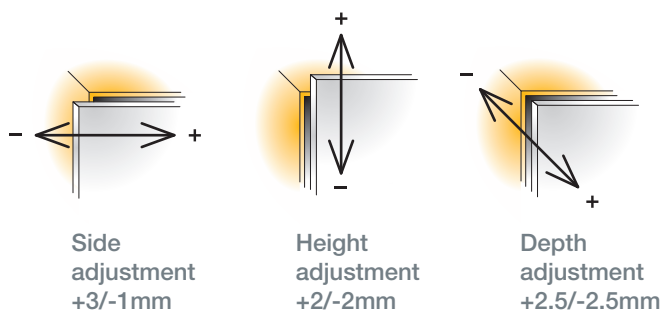

For further explanation → see pages 2.20-2.22

Mounting details

Mounting plate drilling distance

Mounting plate thickness table  
For further explanation → see page 2.11

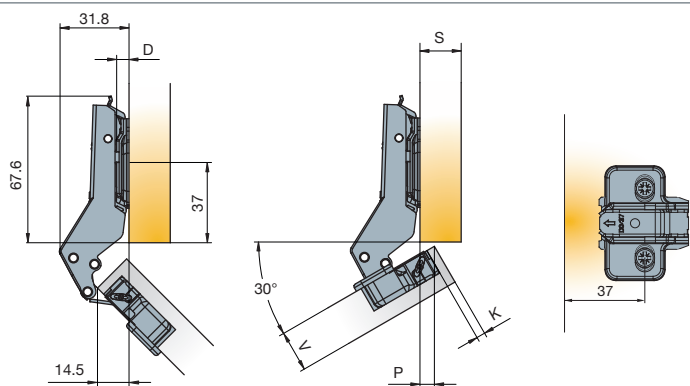

Drawings show application on D=0mm mounting plate

P	1.5	2.5	3.5	4.5	5.5	6.5	7.5	8.5	
3	4	3	2	1	0				
4		4	3	2	1	0			
K			4	3	2	1	0		
5				4	3	2	1	0	
6					4	3	2	1	0
									D

Door clearance at R=1mm  
For further explanation → see page 2.12

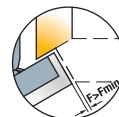

V	16	17	18	19	20	21	22	23	24	25	26	
3	0.5	0.7	0.8	1	1.2	1.5	1.7	2.1	2.8	4.1	5.5	
4	0.4	0.7	0.8	1	1.2	1.5	1.7	2.1	2.3	3.1	4.5	
K												
5	0.4	0.6	0.7	0.9	1.1	1.4	1.6	2	2.2	2.6	3.5	
6	0.4	0.6	0.7	0.9	1.1	1.4	1.6	2	2.2	2.6	2.9	F <sub>MIN</sub>

Gap Z<sub>MIN</sub>=0

# T-type 110/45°

45° angled application for wood doors

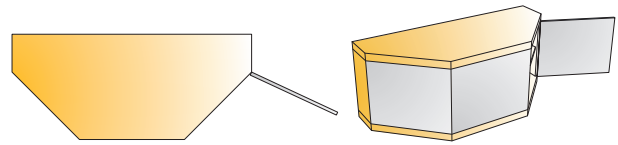
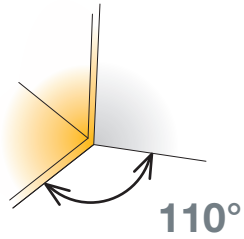

- Opening angle 110°
- Drilling diameter for hinge cup 35mm
- Drilling depth 12mm
- Hinge on plate mounting system 3Way snap-on



Technical details

Cup type	Interaxis 45mm	Interaxis 48mm
	Item number	Item number

Cranking 9mm

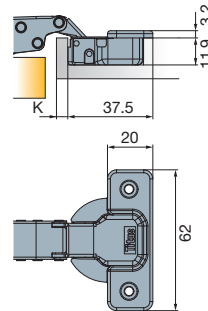
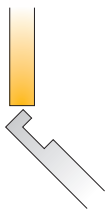

	702-0D81-650	702-0D83-650
	702-0D87-650	702-0D89-650
	702-0D97-650	702-0E18-650

Drilling patterns for hinge cups → see page 2.15

100 Pcs

Cup made of steel, arm made of zinc

Cranking 17mm

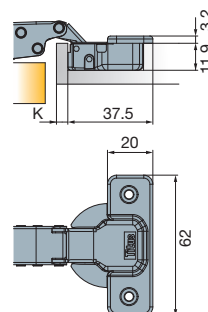
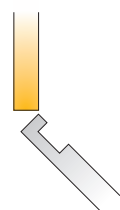

	702-0B07-650	702-0B09-650
	702-0C77-650	702-0C79-650
	702-0C53-650	702-0C55-650

Drilling patterns for hinge cups → see page 2.15

100 Pcs

Cup made of steel, arm made of zinc

Mounting plates  
→ see pages 2.79-2.84



Cover caps for hinge arm  
→ see page 2.173



Hinge cup screws  
If not pre-mounted

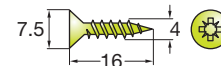

820-6328-050  
10000 Pcs

Hinge angle restrictor  
→ see page 2.171



TouchControl solutions  
→ see pages 2.193-2.204



Soft closing systems  
→ see pages 2.183-2.190



Door adjustment

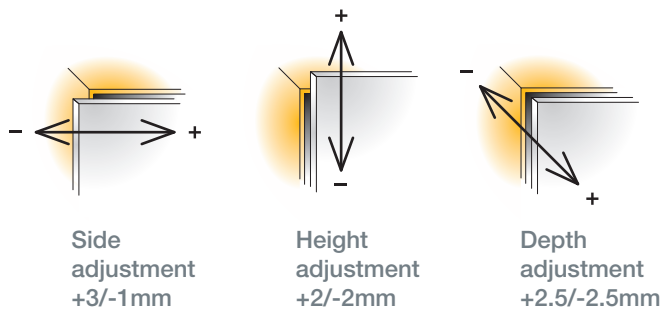

For further explanation → see pages 2.20-2.22

Mounting details

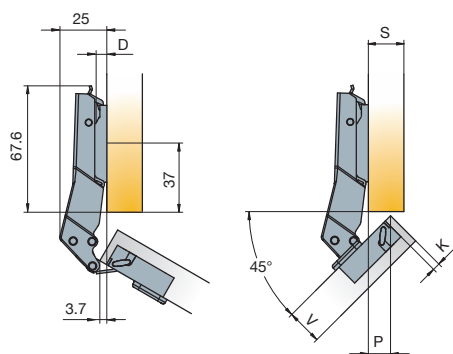

Drawings show application on D=0mm mounting plate

Mounting plate drilling distance

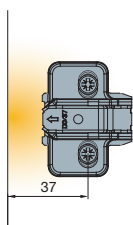

Mounting plate thickness table

For further explanation → see page 2.11

P	7	7.5	8	8.5	9	9.5	10	10.5	11	11.5	12	12.5	13	13.5
3	4		3		2		1		0					
4			4		3		2		1		0			
5				4		3		2		1		0		
6						4		3		2		1		0

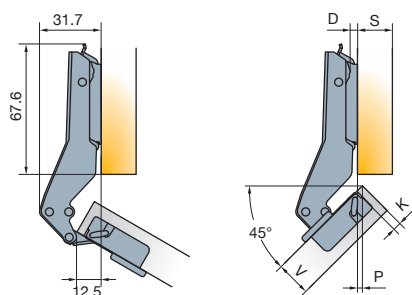

Drawings show application on D=0mm mounting plate

P	0	0.5	1	1.5	2	2.5	3	3.5	4
3		2		1		0			
4	3		2		1		0		
5		3		2		1		0	
6	4		3		2		1		0 D

Door clearance at R=1mm

For further explanation → see page 2.12

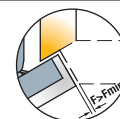

V	16	17	18	19	20	21	22	23	24	25	26
3	0.5	0.7	0.8	1	1.2	1.5	1.7	2.1	2.8	4.1	5.5
4	0.4	0.7	0.8	1	1.2	1.5	1.7	2.1	2.3	3.1	4.5
5	0.4	0.6	0.7	0.9	1.1	1.4	1.6	2	2.2	2.6	3.5
6	0.4	0.6	0.7	0.9	1.1	1.4	1.6	2	2.2	2.6	2.9 F <sub>MIN</sub>

Gap Z<sub>MIN</sub>=0

# T-type 110/90°

For wood door cabinets with blind panels

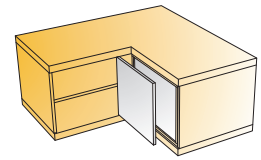
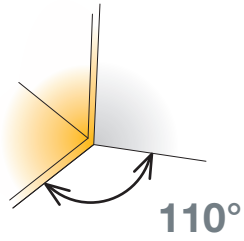

- Opening angle
- Drilling diameter for hinge cup
- Drilling depth
- Hinge on plate mounting system

110°  
35mm  
12mm  
3Way snap-on



Technical details

Cup type	Interaxis 45mm	Interaxis 48mm
Item number	Item number	Item number
Screw-on	702-0A95-650	702-0A97-650
Machine insertion	702-0D35-650	702-0D37-650
EasyFix	702-0D29-650	702-0D31-650

Cranking  
17mm

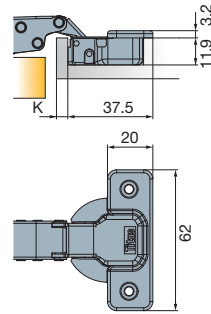
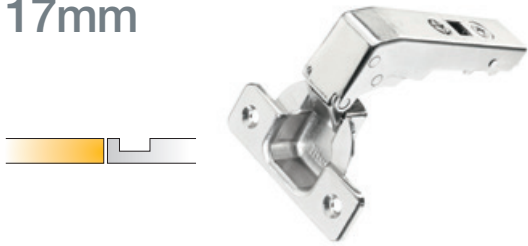

Drilling patterns for hinge cups → see page 2.15

100 Pcs

Cup made of steel, arm made of zinc

Mounting plates  
→ see pages 2.79-2.84



Cover caps for hinge arm  
→ see page 2.173



Hinge cup screws  
If not pre-mounted

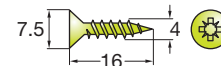

820-6328-050

10000 Pcs

Hinge angle restrictor  
→ see page 2.171



TouchControl solutions  
→ see pages 2.193-2.204



Soft closing systems  
→ see pages 2.183-2.190



· We advise combining with a D=2mm mounting plate.

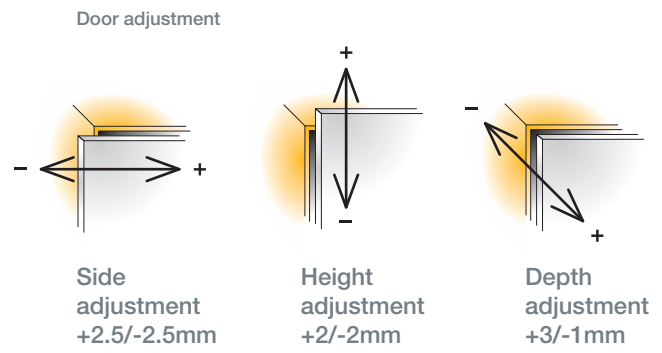

For further explanation → see pages 2.20-2.22

Mounting details

Mounting plate drilling distance

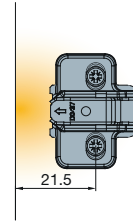
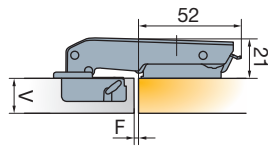
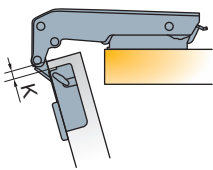

Drawing shows application on D=2mm mounting plate

Door clearance at R=1mm  
For further explanation → see page 2.12

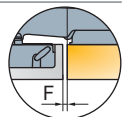

V	16	17	18	19	20	21	22	23	24	25	26	
K	3	0.5	0.7	0.8	1	1.2	1.5	1.7	2.1	2.8	4.1	5.5
	4	0.4	0.7	0.8	1	1.2	1.5	1.7	2.1	2.3	3.1	4.5
	5	0.4	0.6	0.7	0.9	1.1	1.4	1.6	2	2.2	2.6	3.5
	6	0.4	0.6	0.7	0.9	1.1	1.4	1.6	2	2.2	2.6	2.9 F <sub>MIN</sub>

Gap Z<sub>MIN</sub>=0

# T-type 120

For wood doors

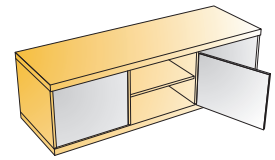
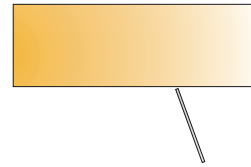
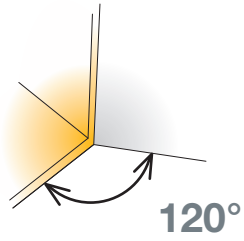

- Opening angle
- Drilling diameter for hinge cup
- Drilling depth
- Hinge on plate mounting system

120°  
35mm  
12mm  
3Way snap-on



Technical details

Cup type	Interaxis 45mm	Interaxis 48mm
Item number	Item number	Item number
Screw-on	702-0UK0-054	702-0UL0-054
Machine insertion	702-0UK1-054	702-0UL1-054
EasyFix	702-0UK4-054	702-0UL4-054

Drilling patterns for hinge cups → see page 2.15

Cranking  
0mm

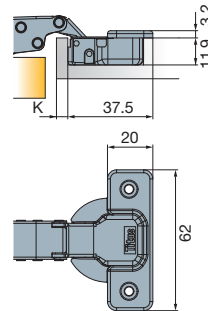
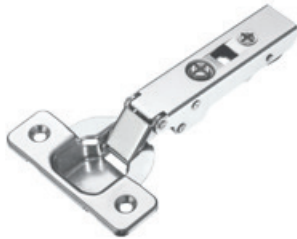

150 Pcs

Made of steel

Mounting plates  
→ see pages 2.79-2.84



Cover caps for hinge arm  
→ see page 2.173



Hinge cup screws  
If not pre-mounted

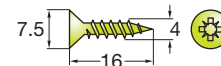

820-6328-050

10000 Pcs

TouchControl solutions  
→ see pages 2.193-2.204



Soft closing systems  
→ see pages 2.183-2.190



Door adjustment

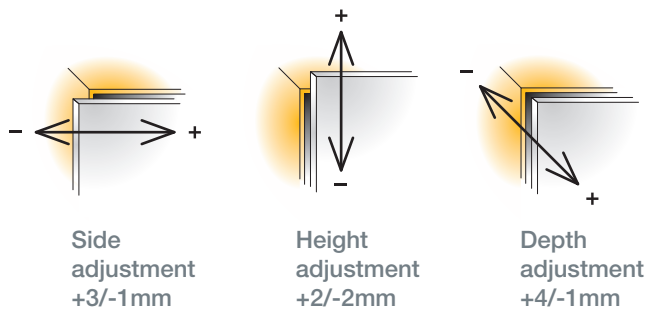

For further explanation → see pages 2.20-2.22

Mounting details

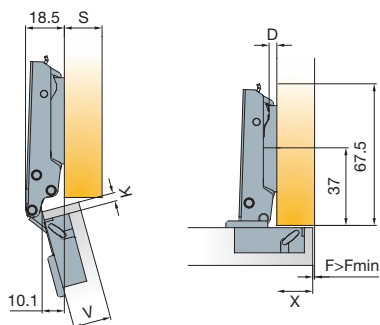

Drawings show application on D=0mm mounting plate

Mounting plate drilling distance

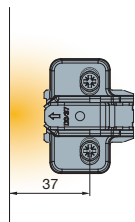

Mounting plate thickness table

For further explanation → see page 2.11

X	13	14	15	16	17	18	19
3	3	2	1	0			
4	4	3	2	1	0		
K							
5		4	3	2	1	0	
6			4	3	2	1	0

$D=13+K-X$

Door clearance at R=1mm

For further explanation → see page 2.12

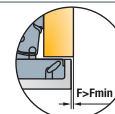

V	16	17	18	19
3	1.1	0.4	0	0
K				
4	2	1.4	0.7	0.1
5	3	2.3	1.6	1

Gap Z<sub>MIN</sub> =2

# T-type 95 Thick Door Hinge

For wood doors

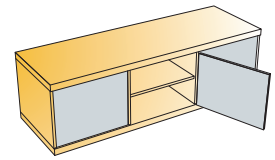
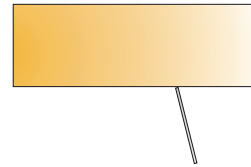
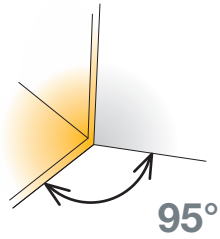

- Opening angle
- Drilling diameter for hinge cup
- Drilling depth
- Hinge on plate mounting system

95°  
35mm  
12mm  
3Way snap-on



Technical details

Cup type	Interaxis 45mm	Interaxis 48mm
	Item number	Item number

Cranking  
0mm

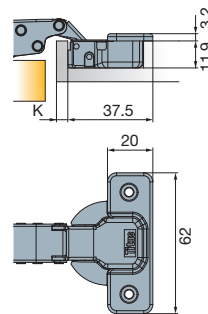
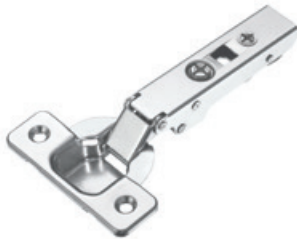
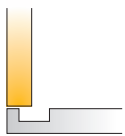

	707-0XK0-054	707-0XL0-054
	707-0XK1-054	707-0XL1-054
	707-0XK4-054	707-0XL4-054

Drilling patterns for hinge cups → see page 2.15

150 Pcs

Made of steel

Cranking  
5mm

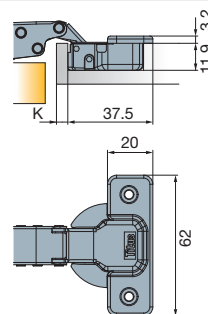

	707-0YK0-054	707-0YL0-054
	707-0YK1-054	707-0YL1-054
	707-0YK4-054	707-0YL4-054

Drilling patterns for hinge cups → see page 2.15

150 Pcs

Made of steel

Mounting plates  
→ see pages 2.79-2.84



Cover caps for hinge arm  
→ see page 2.173



Hinge cup screws  
If not pre-mounted

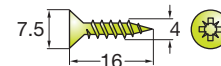

820-6328-050

10000 Pcs

TouchControl solutions  
→ see pages 2.193-2.204



Soft closing systems  
→ see pages 2.183-2.190



Door adjustment

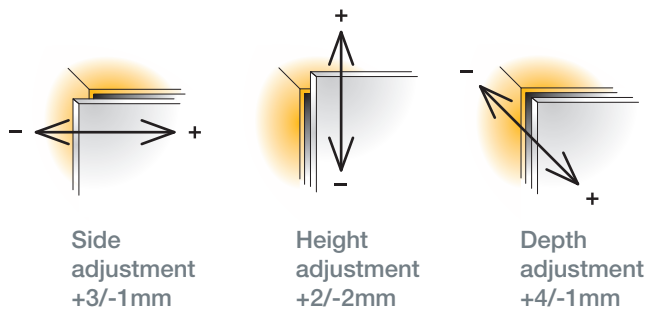

For further explanation → see pages 2.20-2.22

Mounting details

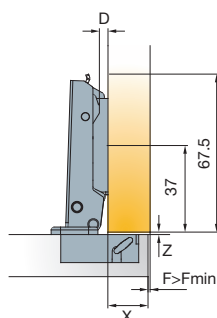
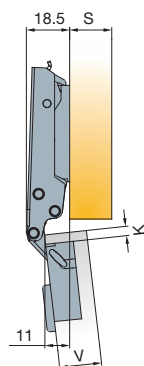

Drawings show application on D=0mm mounting plate

Mounting plate drilling distance

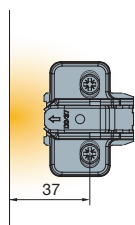

Mounting plate thickness table

For further explanation → see page 2.11

X	13	14	15	16	17	18	19	20	21	22
3	3	2	1	0						
4	4	3	2	1	0					
5		4	3	2	1	0				
K 6			4	3	2	1	0			
7				4	3	2	1	0		
8					4	3	2	1	0	
9						4	3	2	1	0

$D=13+K-X$

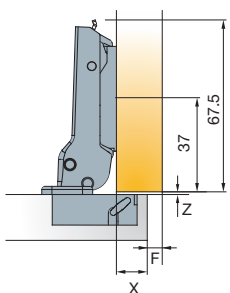
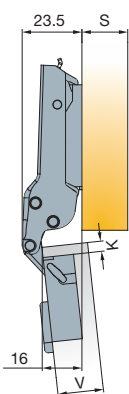

Drawings show application on D=0mm mounting plate

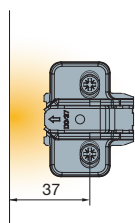

X	8	9	10	11	12	13	14	15	16	17
3	3	2	1	0						
4	4	3	2	1	0					
5		4	3	2	1	0				
K 6			4	3	2	1	0			
7				4	3	2	1	0		
8					4	3	2	1	0	
9						4	3	2	1	0

$D=8+K-X$

Gap Z

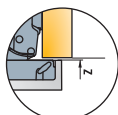

V	20	22	24	26	28	30	32	34	
3	0	0	0	0	0	0	0	0	
4	0	0	0	0	0	0	0	0	
5	0	0	0	0	0	0	0	0	
K 6	0	0	0	0	0	0	0	0	
7	0	0	0	0	0	0	0	0	
8	0	0	0	0	0	0	0	0	
9	0	0	1.6	1.7	1.8	2.0	2.1	2.3	Z <sub>MIN</sub>

Door clearance at R=1mm

For further explanation → see page 2.12

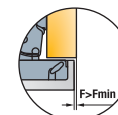

V	20	22	24	26	28	30	32	34	
3	0.6	0.9	1.3	1.7	2.2	4.0	5.9	7.8	
4	0.6	0.9	1.2	1.7	2.2	3.4	5.2	7.1	
5	0.6	0.9	1.2	1.6	2.1	2.9	4.6	6.5	
K 6	0.6	0.9	1.2	1.5	2.1	2.6	4.1	5.9	
7	0.6	0.9	1.2	1.5	2.1	2.6	3.6	5.3	
8	0.6	0.8	1.2	1.5	2.0	2.5	3.2	4.8	
9	0.6	0.8	1.2	1.5	2.0	2.5	3.1	4.4	F <sub>MIN</sub>

# T-type 95 Thick Door Hinge

For wood doors

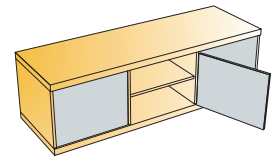
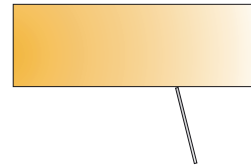
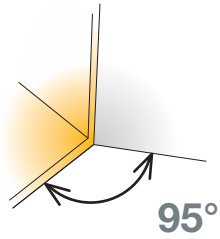

- Opening angle
- Drilling diameter for hinge cup
- Drilling depth
- Hinge on plate mounting system

- 95°
- 35mm
- 12mm
- 3Way snap-on



Technical details

Cup type	Interaxis 45mm	Interaxis 48mm
	Item number	Item number

Cranking  
9mm

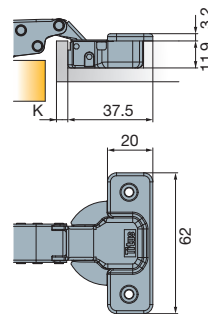
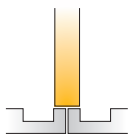

	707-0ZK0-054	707-0ZL0-054
	707-0ZK1-054	707-0ZL1-054
	707-0ZK4-054	707-0ZL4-054

Drilling patterns for hinge cups → see page 2.15

150 Pcs

Made of steel

Cranking  
17mm

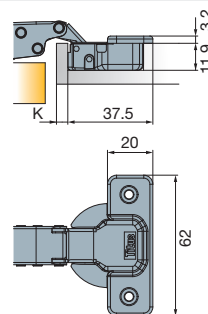
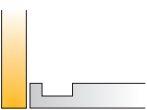

	707-0WK0-054	707-0WL0-054
	707-0WK1-054	707-0WL1-054
	707-0WK4-054	707-0WL4-054

Drilling patterns for hinge cups → see page 2.15

150 Pcs

Made of steel

Mounting plates  
→ see pages 2.79-2.84



Cover caps for hinge arm  
→ see page 2.173



Hinge cup screws  
If not pre-mounted

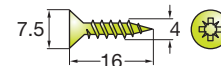

820-6328-050

10000 Pcs

TouchControl solutions  
→ see pages 2.193-2.204



Soft closing systems  
→ see pages 2.183-2.190



Door adjustment

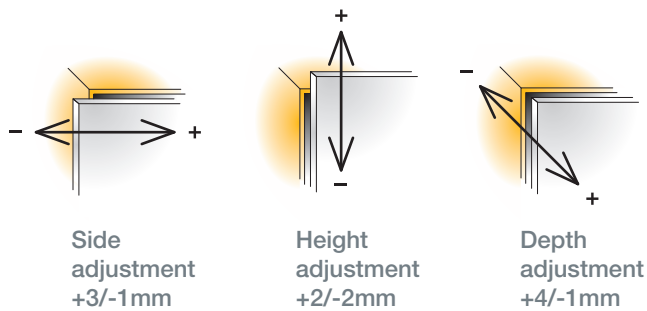

For further explanation → see pages 2.20-2.22

Mounting details

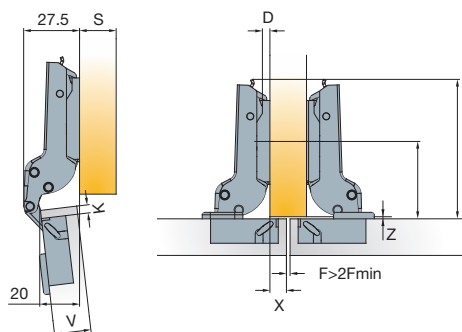

Drawings show application on D=0mm mounting plate

Mounting plate drilling distance

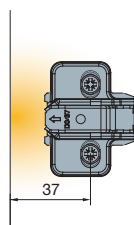

Mounting plate thickness table

For further explanation → see page 2.11

X	4	5	6	7	8	9	10	11	12	13
3	3	2	1	0						
4	4	3	2	1	0					
5		4	3	2	1	0				
K 6			4	3	2	1	0			
7				4	3	2	1	0		
8					4	3	2	1	0	
9						4	3	2	1	0

$D=4+K-X$

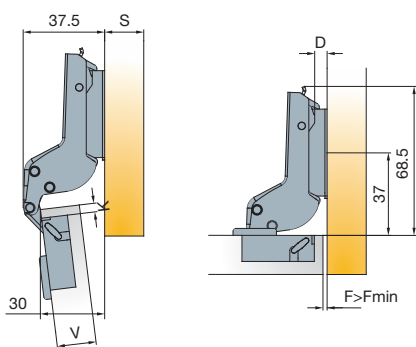

Drawings show application on D=2mm mounting plate

V	20	22	24	26	28	30	32
3	0	0	1	1	2	3	4*
4	1	1	2	2	3	4	4*
K 5	2	2	3	3	4	4	4*
6	3	3	4	4	4*	4*	
7	4	4	4*	4*	4*	4*	

$D=-4+K+F$

\*Hinge adjustment needed

Gap Z

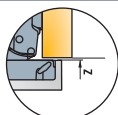

V	20	22	24	26	28	30	32	34
3	0	0	0	0	0	0	0	0
4	0	0	0	0	0	0	0	0
5	0	0	0	0	0	0	0	0
K 6	0	0	0	0	0	0	0	0
7	0	0	0	0	0	0	0	0
8	0	0	0	0	0	0	0	0
9	0	0	1.6	1.7	1.8	2.0	2.1	2.3

**Z<sub>MIN</sub>**

Door clearance at R=1mm

For further explanation → see page 2.12



V	20	22	24	26	28	30	32	34
3	0.6	0.9	1.3	1.7	2.2	4.0	5.9	7.8
4	0.6	0.9	1.2	1.7	2.2	3.4	5.2	7.1
5	0.6	0.9	1.2	1.6	2.1	2.9	4.6	6.5
K 6	0.6	0.9	1.2	1.5	2.1	2.6	4.1	5.9
7	0.6	0.9	1.2	1.5	2.1	2.6	3.6	5.3
8	0.6	0.8	1.2	1.5	2.0	2.5	3.2	4.8
9	0.6	0.8	1.2	1.5	2.0	2.5	3.1	4.4

**F<sub>MIN</sub>**

# T-type 110 Unsprung Hinge

For wood doors

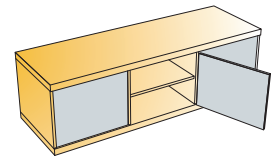
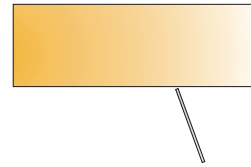
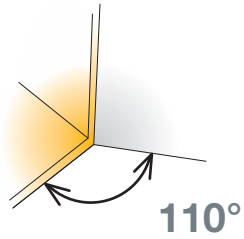

- Opening angle
- Drilling diameter for hinge cup
- Drilling depth
- Hinge on plate mounting system

110°  
35mm  
12mm  
3Way snap-on



Technical details

Cup type	Interaxis 45mm	Interaxis 48mm
	Item number	Item number

Cranking  
0mm

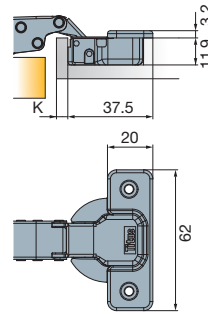
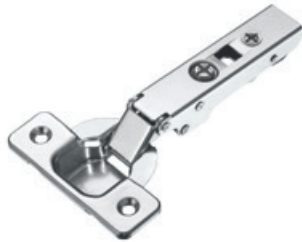

	704-0593-054	704-0672-054
		704-0553-054

Drilling patterns for hinge cups → see page 2.15

150 Pcs

Made of steel

Cranking  
5mm

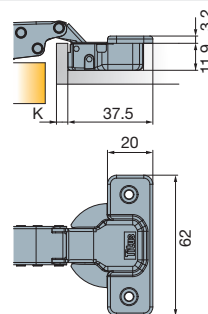
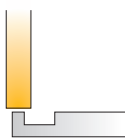

	704-0661-054	704-0673-054
		704-0604-054

Drilling patterns for hinge cups → see page 2.15

150 Pcs

Made of steel

Mounting plates  
→ see pages 2.79-2.84



Cover caps for hinge arm  
see page 2.173



Hinge cup screws  
If not pre-mounted

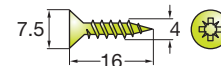

820-6328-050  
10000 Pcs

Hinge angle restrictor  
→ see page 2.171



TouchControl solutions  
→ see pages 2.193-2.204



· Concealed hinge without spring to be used with PushOpen mechanisms with magnet

→ see pages 2.207-2.210



Touch

Door adjustment

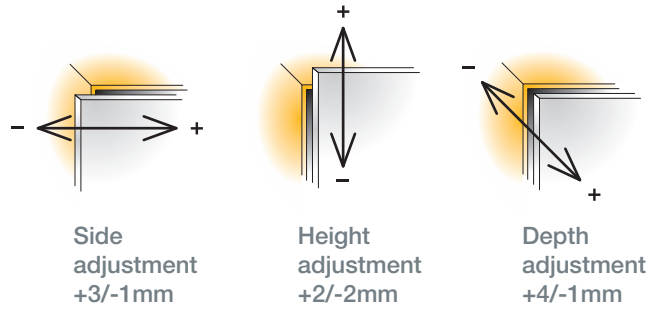

For further explanation → see pages 2.20-2.22

Mounting details

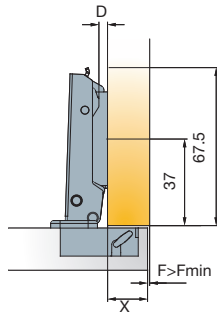
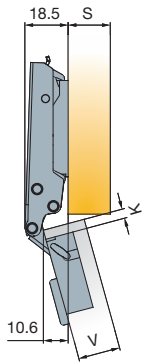

Mounting plate drilling distance

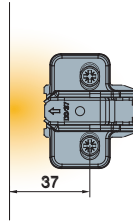

Mounting plate thickness table

For further explanation → see page 2.11

X	13	14	15	16	17	18	19
3	3	2	1	0			
4	4	3	2	1	0		
K							
5		4	3	2	1	0	
6			4	3	2	1	0
							D

$D=13+K-X$

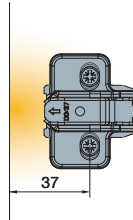
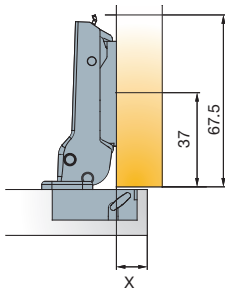
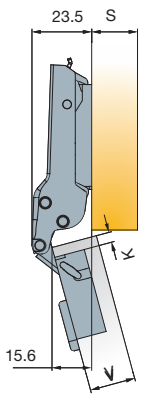

X	8	9	10	11	12	13	14
3	3	2	1	0			
4	4	3	2	1	0		
K							
5		4	3	2	1	0	
6			4	3	2	1	0
							D

$D=8+K-X$

Door clearance at R=1mm

For further explanation → see page 2.12

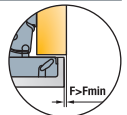

V	16	17	18	19	20	21	22	23	24	25	26
3	0.5	0.7	0.8	1	1.2	1.5	1.7	2.1	2.8	4.1	5.5
4	0.4	0.7	0.8	1	1.2	1.5	1.7	2.1	2.3	3.1	4.5
K											
5	0.4	0.6	0.7	0.9	1.1	1.4	1.6	2	2.2	2.6	3.5
6	0.4	0.6	0.7	0.9	1.1	1.4	1.6	2	2.2	2.6	2.9
											F <sub>MIN</sub>

Gap Z<sub>MIN</sub>=0

# T-type 110 Unsprung Hinge

For wood doors

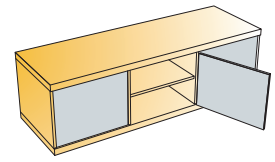
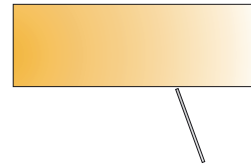
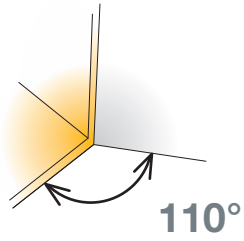

- Opening angle
- Drilling diameter for hinge cup
- Drilling depth
- Hinge on plate mounting system

110°  
35mm  
12mm  
3Way snap-on



Technical details

Cup type	Interaxis 45mm	Interaxis 48mm
Screw-on	704-0595-054	704-0674-054
EasyFix		704-0697-054

Cranking  
9mm

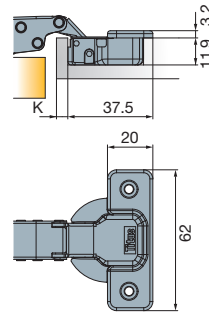
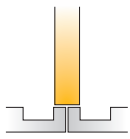

Drilling patterns for hinge cups → see page 2.15

150 Pcs

Made of steel

Mounting plates  
→ see pages 2.79-2.84



Cover caps for hinge arm  
see page 2.173



Hinge cup screws  
If not pre-mounted

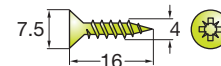

820-6328-050

10000 Pcs

Hinge angle restrictor  
→ see page 2.171



TouchControl solutions  
see pages 2.193-2.204



· Concealed hinge without spring to be used with PushOpen mechanisms with magnet

→ see pages 2.207-2.210



Touch

Door adjustment

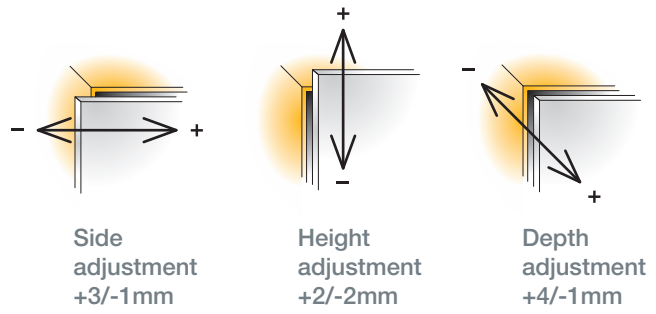

For further explanation → see pages 2.20-2.22

Mounting details

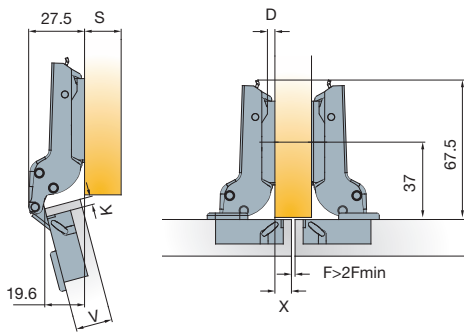

Mounting plate drilling distance

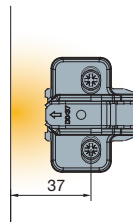

Mounting plate thickness table

For further explanation → see page 2.11

X	4	5	6	7	8	9	10
3	3	2	1	0			
4	4	3	2	1	0		
5		4	3	2	1	0	
6			4	3	2	1	0

**D=4+K-X**

Door clearance at R=1mm

For further explanation → see page 2.12

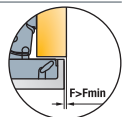

V	16	17	18	19	20	21	22	23	24	25	26
3	0.5	0.7	0.8	1	1.2	1.5	1.7	2.1	2.8	4.1	5.5
4	0.4	0.7	0.8	1	1.2	1.5	1.7	2.1	2.3	3.1	4.5
5	0.4	0.6	0.7	0.9	1.1	1.4	1.6	2	2.2	2.6	3.5
6	0.4	0.6	0.7	0.9	1.1	1.4	1.6	2	2.2	2.6	2.9 F <sub>MIN</sub>

Gap Z<sub>MIN</sub>=0

# T-type 170

For wood doors

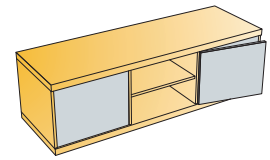
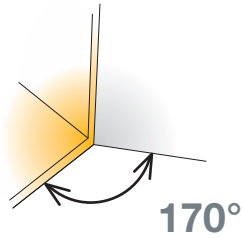

- Opening angle
- Drilling diameter for hinge cup
- Drilling depth
- Hinge on plate mounting system

165°  
35mm  
12mm  
3Way snap-on



Technical details

Cup type	Interaxis 45mm	Interaxis 48mm
Item number	Item number	Item number
Screw-on Machine insertion EasyFix	702-0EK0-054	702-0EL0-054
	702-0EK1-054	702-0EL1-054
	702-0EK4-054	702-0EL4-054

Drilling patterns for hinge cups → see page 2.15

Cranking  
0mm

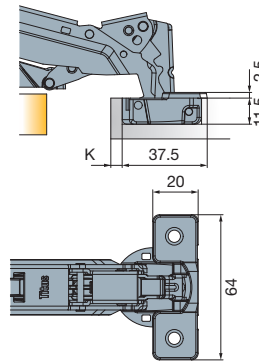

50 Pcs

Made of steel and zinc

Mounting plates  
→ see pages 2.79-2.84



Hinge cup screws  
If not pre-mounted

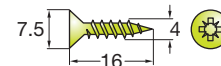

820-6328-050

10000 Pcs

Hinge angle restrictor  
→ see page 2.171



TouchControl solutions  
see pages 2.193-2.204



Soft closing systems  
→ see page 2.185



Zero protrusion  
with D=0 mounting plate

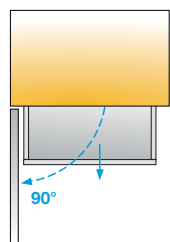

Door adjustment

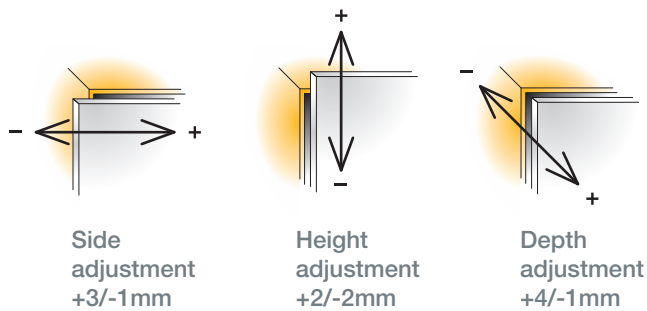

For further explanation → see pages 2.20-2.22

Mounting  
details

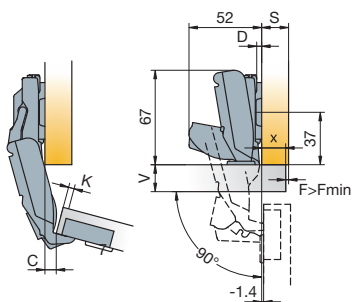

Drawings show application on  
D=0mm mounting plate  
No door protrusion in  
90° position

Mounting plate  
drilling distance

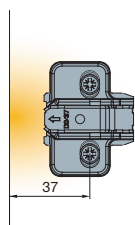

Mounting plate thickness table

For further explanation → see page 2.11

X	13	14	15	16	17	18	19	20
3	3	2	1	0				
4	4	3	2	1	0			
5		4	3	2	1	0		
6			4	3	2	1	0	
7				4	3	2	1	0

$D=13+K-X$

C value with D=0 mounting plates

K	3	4	5	6	7	
C	-9.0	-8.1	-7.1	-6.1	-5.2	D

Door clearance at R=1mm

For further explanation → see page 2.12

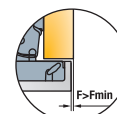

V	16	17	18	19	20	21	22	23	24
3	0.0	0.0	0.0	0.0	0.0	0.0	0.0	0.0	0.0
4	0.0	0.0	0.0	0.0	0.0	0.0	0.0	0.0	0.0
K 5	0.0	0.0	0.0	0.0	0.0	0.0	0.0	0.0	0.0
6	0.0	0.0	0.0	0.0	0.0	0.0	0.0	0.0	2.6
7	0.0	0.0	0.0	0.0	0.0	0.0	0.0	0.0	5.1

Gap  $Z_{MIN}=0.5$

# T-type 170

For wood doors

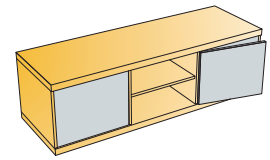
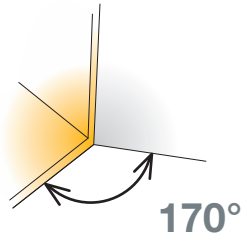

- Opening angle
- Drilling diameter for hinge cup
- Drilling depth
- Hinge on plate mounting system

165°  
35mm  
12mm  
3Way snap-on



Technical details

Cup type	Interaxis 45mm	Interaxis 48mm
	Item number	Item number

Cranking  
5mm

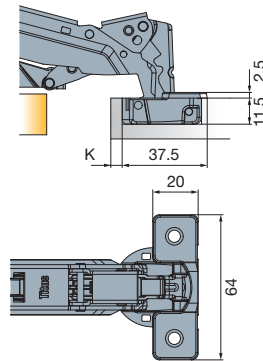

	702-0FK0-054	702-0FL0-054
	702-0FK1-054	702-0FL1-054
	702-0FK4-054	702-0FL4-054

Drilling patterns for hinge cups → see page 2.15

50 Pcs

Made of steel and zinc

Cranking  
9mm

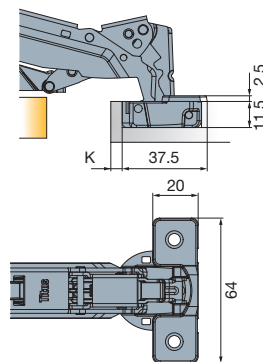
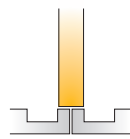

	702-0GK0-054	702-0GL0-054
	702-0GK1-054	702-0GL1-054
	702-0GK4-054	702-0GL4-054

Drilling patterns for hinge cups → see page 2.15

50 Pcs

Made of steel and zinc

Mounting plates  
see pages 2.79-2.84



Hinge cup screws  
If not pre-mounted

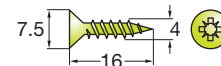

820-6328-050

10000 Pcs

Hinge angle restrictor  
see page 2.171



TouchControl solutions  
→ see pages 2.193-2.204



Soft closing systems  
→ see page 2.185



Door adjustment

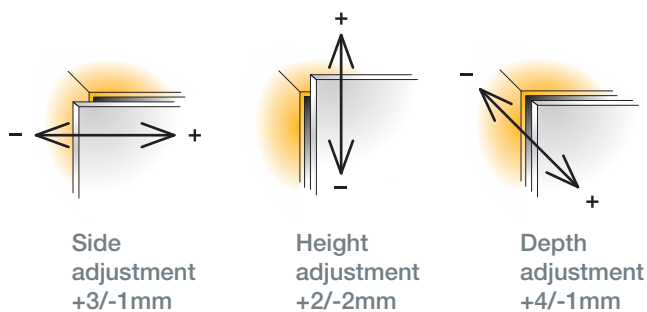

For further explanation → see pages 2.20-2.22

Mounting details

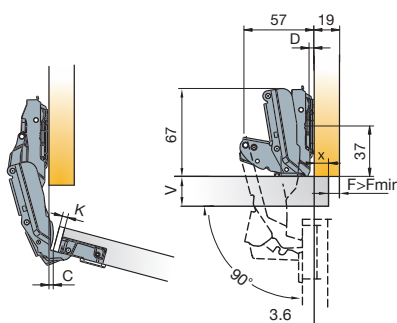

Drawings show application on D=0mm mounting plate

Mounting plate drilling distance

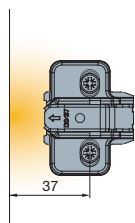

Mounting plate thickness table

For further explanation → see page 2.11

X	8	9	10	11	12	13	14
3	3	2	1	0			
4	4	3	2	1	0		
K	5	4	3	2	1	0	
6		4	3	2	1	0	D

$D=8+K-X$

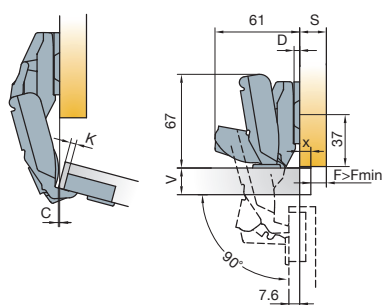

Drawings show application on D=0mm mounting plate

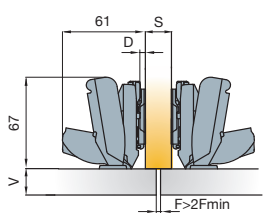

Drawing show application on D=0mm mounting plate

X	1	2	3	4	5	6	7	8	9	10	11
3	6			3	2	1	0				
4		6			3	2	1	0			
K	5		6			3	2	1	0		
6				6			3	2	1	0	
7					6			3	2	1	0

$D=4+K-X$

Door clearance at R=1mm

For further explanation → see page 2.12

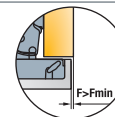

V	16	17	18	19	20	21	22	23	24
3	0.0	0.0	0.0	0.0	0.0	0.0	0.0	0.0	0.0
4	0.0	0.0	0.0	0.0	0.0	0.0	0.0	0.0	0.0
K	5	0.0	0.0	0.0	0.0	0.0	0.0	0.0	0.0
6	0.0	0.0	0.0	0.0	0.0	0.0	0.0	0.0	2.6
7	0.0	0.0	0.0	0.0	0.0	0.0	0.0	0.0	5.1

Gap  $Z_{MIN}=0.5$

# T-type for Pie-cut Corner Cabinet

For wood doors

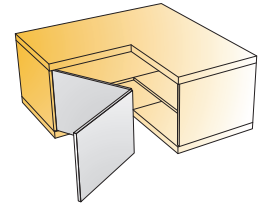

- Opening angle 70°/25°
- Drilling diameter for hinge cup 35mm
- Drilling depth 12mm
- Hinge on plate mounting system 3Way snap-on



Technical details

Cup type	Interaxis 45mm	Interaxis 48mm
Item number	721-0PK0-650	721-0PL0-650
Item number	721-0PK4-650	721-0PL4-650

Corner cabinet

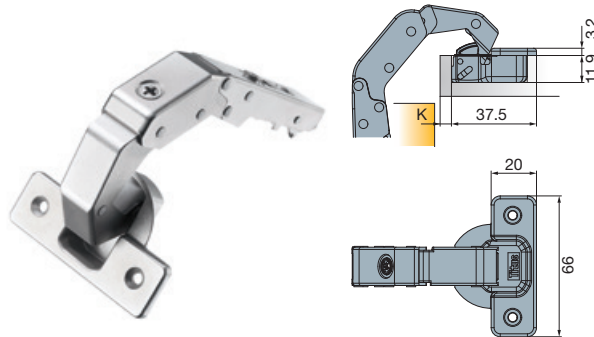
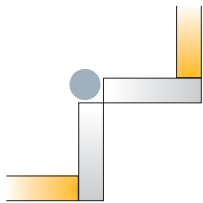

Drilling patterns for hinge cups → see page 2.15

50 Pcs

Cup made of zinc, arm made of steel

Mounting plates  
see pages 2.79-2.84



Cover caps for hinge arm  
→ see page 2.173



Hinge cup screws  
If not pre-mounted

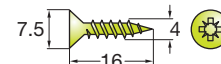

820-6328-050

10000 Pcs

TouchControl solutions  
→ see pages 2.193-2.204



· Use in pair with 170° hinge

Door adjustment

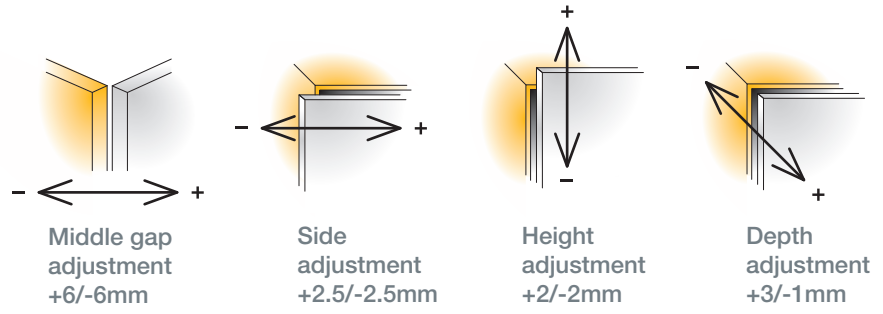

For further explanation → see pages 2.20-2.22

Mounting details

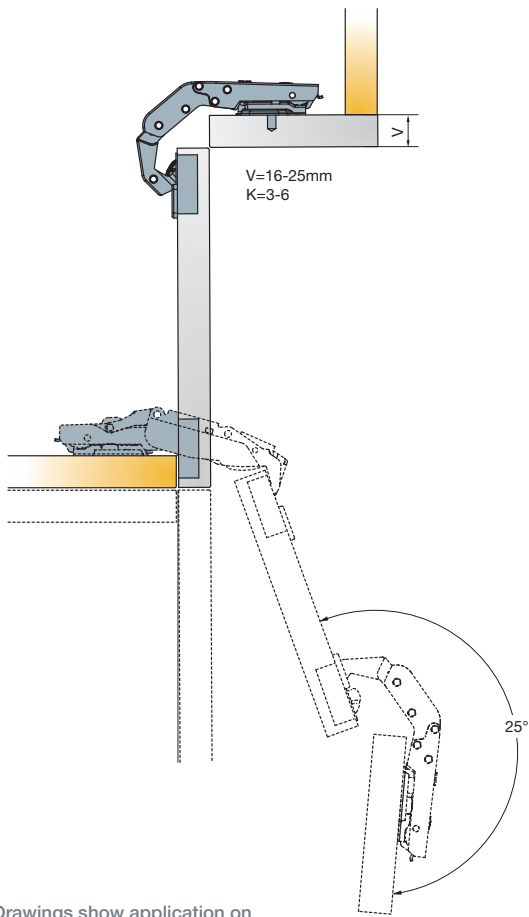

Drawings show application on D=2mm mounting plate

Mounting plate drilling distance

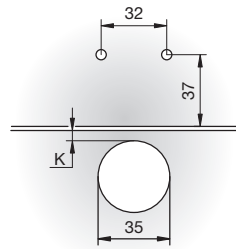

Any T-type mounting plate can be used

Adjustments

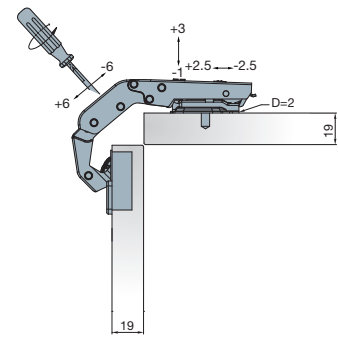

The adjustment of the gap between two doors is done by rotating the adjustment screw as shown on the drawing

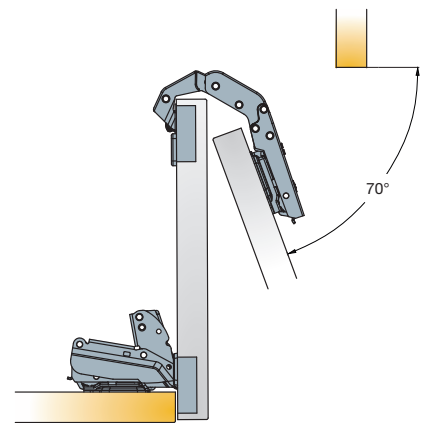

# T-type Mounting Plates

3Way snap-on mounting

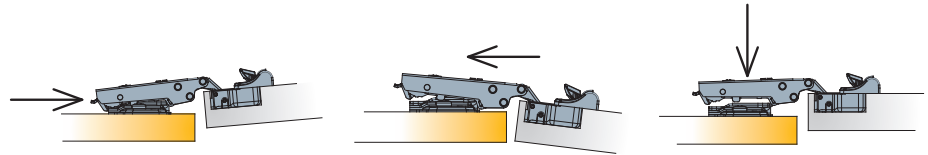

Cam adjustable cruciform  
mounting plate 37mm

Drilling pattern

Dimensions

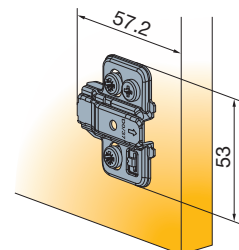
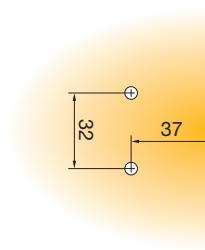

150 Pcs Made of steel

Cam adjustable linear  
mounting plate

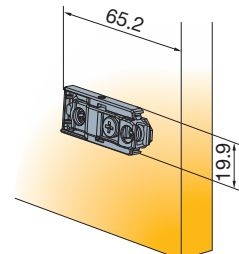
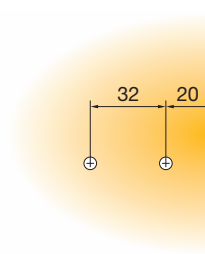

150 Pcs Made of steel and zinc



Mounting plate thickness

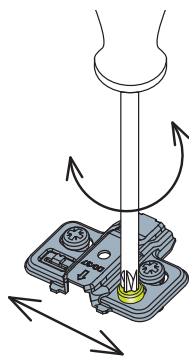

Height adjustment +2/-2mm

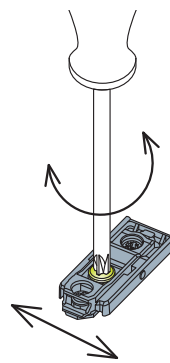

Height adjustment +2/-2mm

Mounting plate type	15	10.5	10.5	15	
Mounting plate thickness (D)	 min 11.5 Ø5	 min 10.5 Ø10	 min 10.5 Ø5	 min 15	no pre-drilling required
Item number					
0mm	700-0KC0-054	700-0KB0-054	700-0KF0-054	700-0KA0-054	
1mm	700-0KC1-054	700-0KB1-054	700-0KF1-054	700-0KA1-054	
2mm	700-0KC2-054	700-0KB2-054	700-0KF2-054	700-0KA2-054	
3mm	700-0KC3-054	700-0KB3-054	700-0KF3-054	700-0KA3-054	
4mm	700-0KC4-054	700-0KB4-054	700-0KF4-054	700-0KA4-054	
0mm	700-0LC0-650	700-0LB0-650	700-0LF0-650		
2mm	700-0LC2-650	700-0LB2-650	700-0LF2-650		
3mm	700-0LC3-650	700-0LB3-650	700-0LF3-650		

Legend of mounting plate type symbols



Pre-mounted 15mm euro screws



Machine insertion ready



Pre-mounted 10.5mm expanding dowels



Pre-mounted chipboard screw

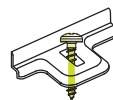
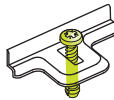
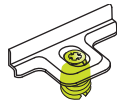
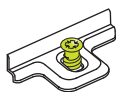

# T-type Mounting Plates

3Way snap-on mounting

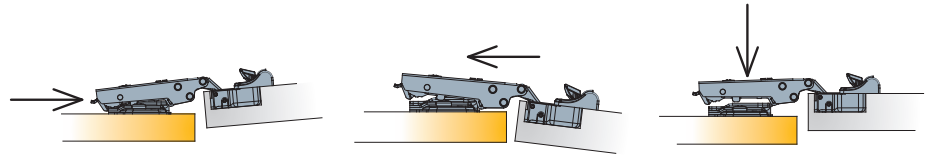

Cruciform mounting plate 37mm

Drilling pattern

Dimensions

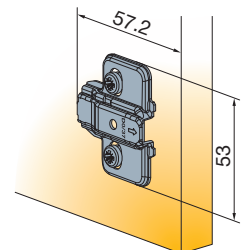
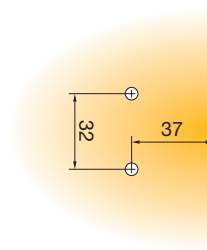

150 Pcs

Made of steel

Fixing screw for cruciform mounting plate  
If not pre-mounted

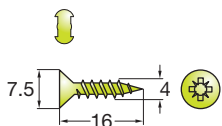

Chipboard screws  
820-6328-050



10000 Pcs



Mounting plate thickness

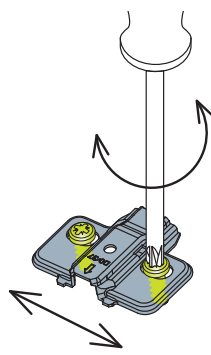



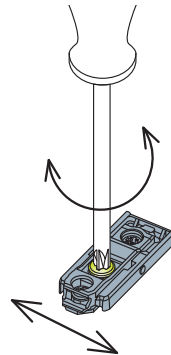







Height adjustment +2/-2mm



Height adjustment +2/-2mm

Mounting plate type		 15	 10.5	 10.5	 14.5	
Mounting plate thickness (D)						
Item number	Item number	Item number	Item number	Item number	Item number	
0mm	700-0NA0-054	700-0NC0-054	700-0NB0-054	700-0NF0-054	700-0NE0-054	
1mm	700-0NA1-054	700-0NC1-054	700-0NB1-054	700-0NF1-054	700-0NE1-054	
2mm	700-0NA2-054	700-0NC2-054	700-0NB2-054	700-0NF2-054	700-0NE2-054	
3mm	700-0NA3-054	700-0NC3-054	700-0NB3-054	700-0NF3-054	700-0NE3-054	
4mm	700-0NA4-054	700-0NC4-054	700-0NB4-054	700-0NF4-054	700-0NE4-054	
9mm	700-0NA9-650	700-0NC9-650		700-0NF9-650		

Legend of mounting plate type symbols

	 15	 10.5	 10.5	 14.5
Screw-on ready for chipboard screws ← screws	Pre-mounted 15mm euro screws	Machine insertion ready	Pre-mounted 10.5mm expanding dowels	Pre-mounted chipboard screw
				

# T-type

## Mounting Plates for Face Frame Cabinets

3Way snap-on mounting

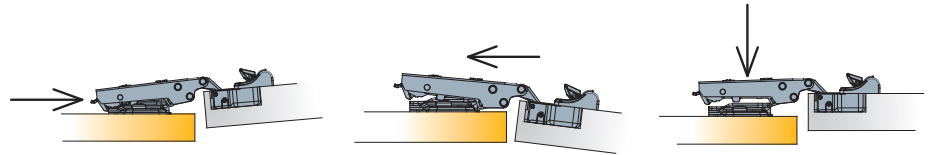

Cam adjustable face frame mounting plate

Drilling pattern

Dimensions

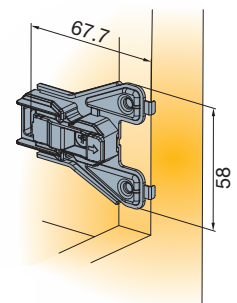
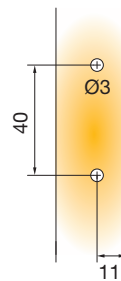

 150 Pcs    Made of steel and zinc

Cam adjustable face frame mounting plate inset mounting

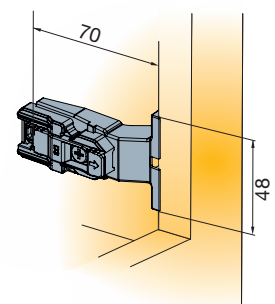
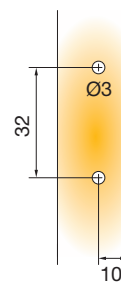

 150 Pcs    Made of steel and zinc

Fixing screw for cruciform mounting plate  
*If not pre-mounted*

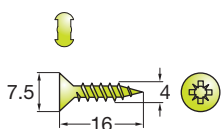

Chipboard screws  
820-6328-050

 10000 Pcs

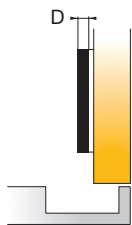



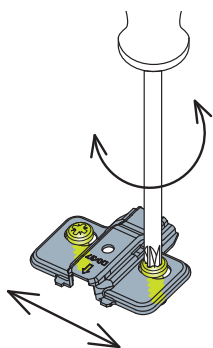

Mounting plate thickness

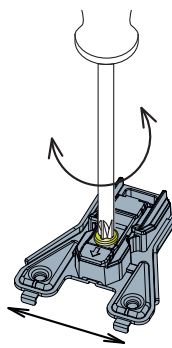

Height adjustment +2/-2mm













Height adjustment +2/-2mm

Mounting plate type		 15	 10.5	 10.5	 14.5		
Mounting plate thickness (D)							
Item number							
0mm						700-0KW0-650	
3mm						700-0KW3-650	
6mm						700-0KW6-650	
inset	700-0KWN-054						

**i** Combine with C9mm hinge arm cranking

Legend of mounting plate type symbols

	 15	 10.5	 10.5	 14.5
Screw-on ready for chipboard screws ← screws	Pre-mounted 15mm euro screws	Machine insertion ready	Pre-mounted 10.5mm expanding dowels	Pre-mounted chipboard screw
				

# S-type Hinges

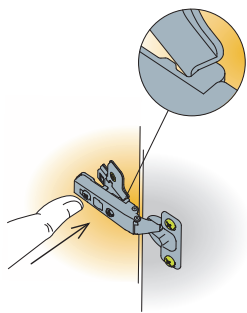

## Snap-on mounting system

- Easy and quick assembly and disassembly
- Flexibility for the furniture user
- Tight hinge-to-plate joint improves hinge stability and reduces door sag

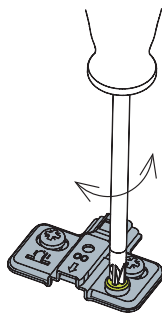

## Easily accessible height adjustment with cam

- Intuitive and quick height adjustment
- Consumer friendly

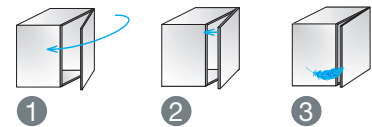

## ConfidentClose

- 1 Fast closing
- 2 Late start of deceleration action
- 3 Quiet landing with SoftTouch

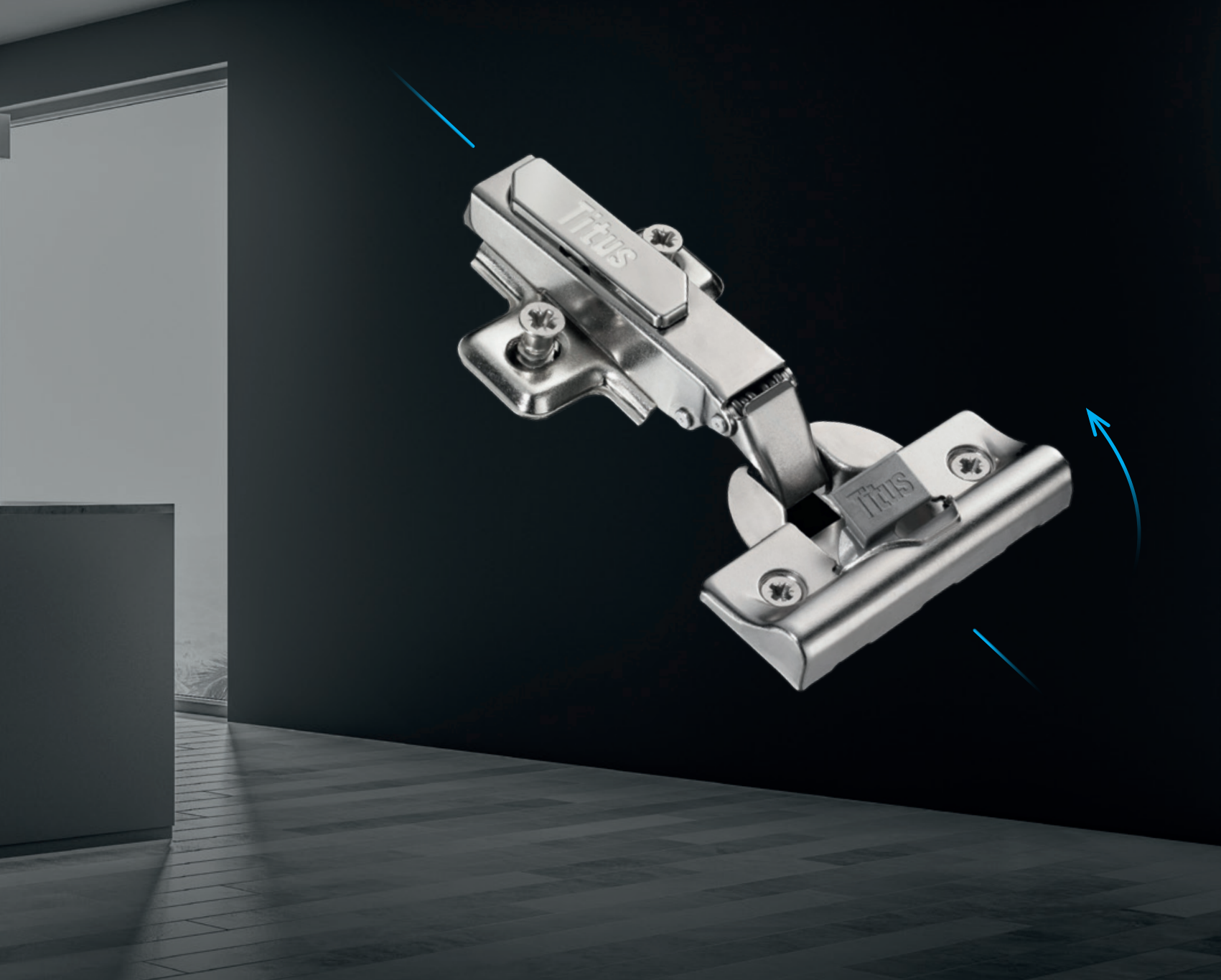

### Titus Damper Inside

- Titus proprietary multi-purpose damping technology
- Reliable and consistent life-long damping

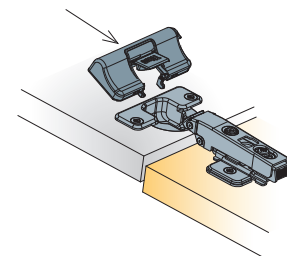

### Soft closing options

- Integrated
- Glissando add-on
- Stand-alone

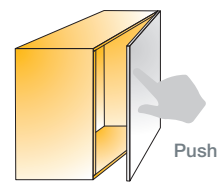

### Touch opening

- Guarantees effortless opening
- Elegant cabinet design
- Doors without handles

# S-type-i3 110

For wood doors

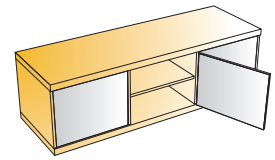
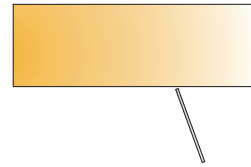
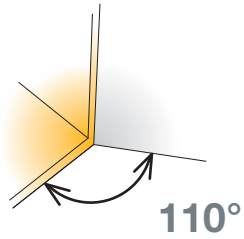

- Opening angle
- Drilling diameter for hinge cup
- Drilling depth
- Hinge on plate mounting system

110°  
35mm  
min. 11mm  
snap-on



Technical details

Cup type	Interaxis 45mm	Interaxis 48mm
Item number	242-0970-054	242-0971-054

Cranking  
0mm



200 Pcs



Made of steel and plastic

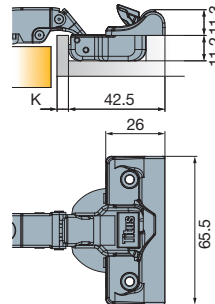

Screw-on	242-0970-054	242-0971-054
	Drilling patterns for hinge cups → see page 2.15	

Cranking  
9mm

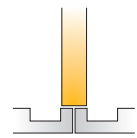

200 Pcs



Made of steel and plastic

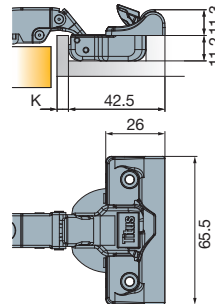

Screw-on	242-0976-054	242-0977-054
	Drilling patterns for hinge cups → see page 2.15	

Cranking  
15mm

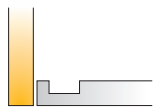

200 Pcs



Made of steel and plastic

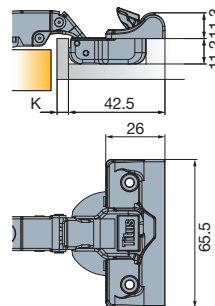

Screw-on	242-0997-054	242-0998-054
	Drilling patterns for hinge cups → see page 2.15	

Mounting plates  
→ see pages 2.123-2.128



Cover caps for hinge arm  
→ see page 2.173



Hinge cup screws  
If not pre-mounted

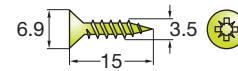

820-6308-050

10000 Pcs

Hinge angle restrictor  
→ see page 2.171



TouchControl solutions  
→ see pages 2.193-2.204



Door adjustment

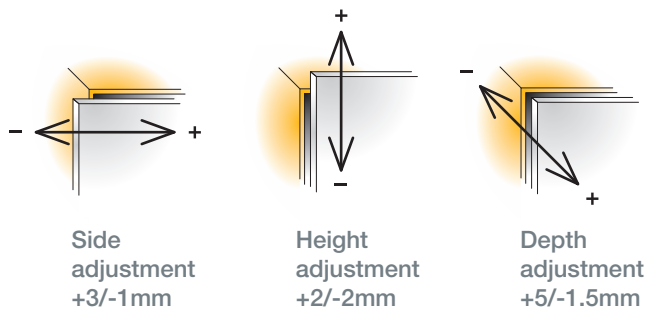

For further explanation → see pages 2.20-2.22

Mounting details

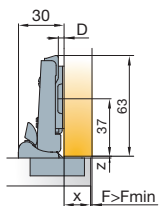
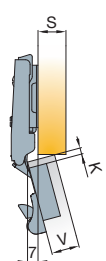

Drawings show application on D=0mm mounting plate

Mounting plate drilling distance

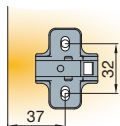

Mounting plate thickness table

For further explanation → see page 2.11

X	13	14	15	16	17	18
3	3	2	1	0		
K	4	3	2	1	0	
5			3	2	1	0

$D=13+K-X$

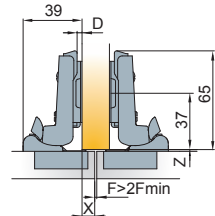
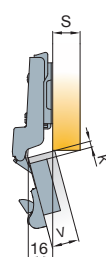

Drawings show application on D=0mm mounting plate

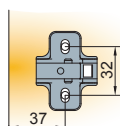

X	4	5	6	7	8	9
3	3	2	1	0		
K	4	3	2	1	0	
5			3	2	1	0

$D=4+K-X$

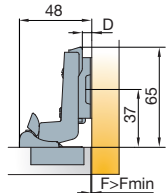
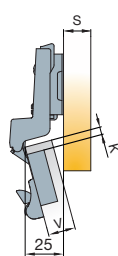

Drawings show application on D=3mm mounting plate

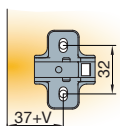

V	16	17	18	19	20	21
3	2	2	2	3	3	3
K	4	3	3	3		
5	3					

$D=-2+K+F$

Door clearance

For further explanation → see page 2.12

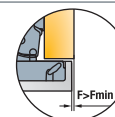

V	16	17	18	19	20	21	22
3	0.3	0.5	0.7	1.0	1.3	1.7	2.5
K	4	0.3	0.5	0.7	0.9	1.2	1.6
5	0.3	0.5	0.7	0.9	1.2	1.5	2.0

Gap  $Z_{MIN}=0$

# S-type-i3 110/15°

For wood doors

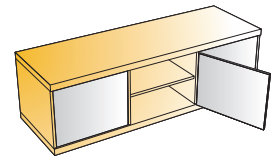
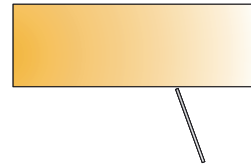
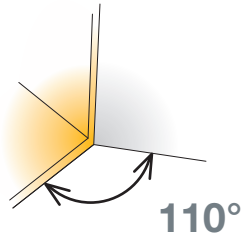

- Opening angle
- Drilling diameter for hinge cup
- Drilling depth
- Hinge on plate mounting system

110°  
35mm  
min. 11mm  
snap-on



Technical details

	Interaxis 45mm	Interaxis 48mm
Cup type		
Item number	242-0W71-650	242-0W72-650
		Screw-on

Drilling patterns for hinge cups → see page 2.15

Cranking  
9mm

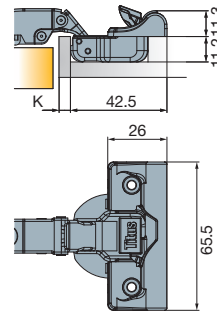
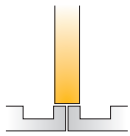

200 Pcs

Made of steel and plastic

Mounting plates

→ see pages 2.123-2.128



Cover caps for hinge arm

→ see page 2.173



Hinge cup screws

If not pre-mounted

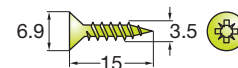

820-6308-050

10000 Pcs

Hinge angle restrictor

→ see page 2.171



TouchControl Solutions

→ see pages 2.193-2.204



Door adjustment

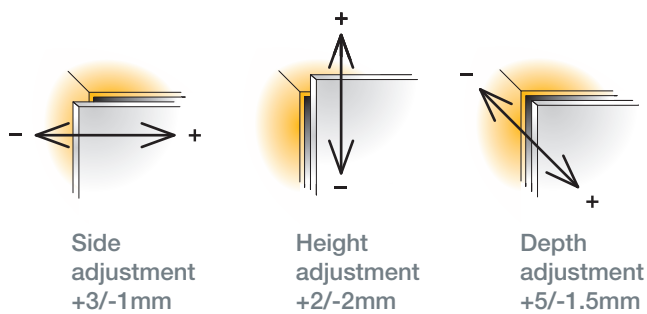

For further explanation → see pages 2.20-2.22

Mounting details

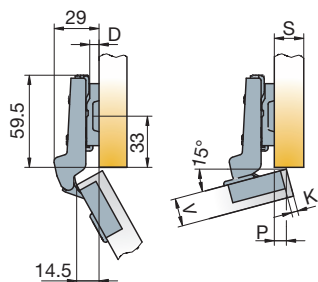

Drawings show application on D=0 and K=4mm mounting plate

Mounting plate drilling distance

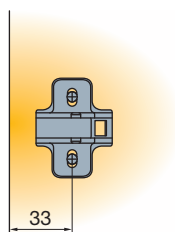

Mounting plate thickness table

For further explanation → see page 2.11

X	4	5	6	7	8	9
3	3	2	1	0		
K 4		3	2	1	0	
5			3	2	1	0

$D=4+K-X$

Door clearance

For further explanation → see page 2.12



V	16	17	18	19	20	21	22
3	0.3	0.5	0.7	1.0	1.3	1.7	2.5
K 4	0.3	0.5	0.7	0.9	1.2	1.6	2.1
5	0.3	0.5	0.7	0.9	1.2	1.5	2.0

Gap  $Z_{MIN}=0$

# S-type-i3 110/24°

For wood doors

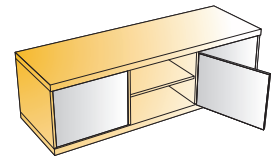
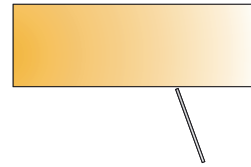
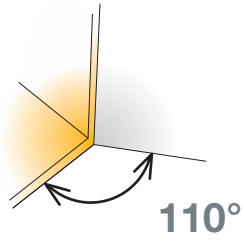

- Opening angle
- Drilling diameter for hinge cup
- Drilling depth
- Hinge on plate mounting system

110°  
35mm  
min. 11mm  
snap-on



Technical details

Cup type	Interaxis 45mm	Interaxis 48mm
Item number		

Cranking  
9mm

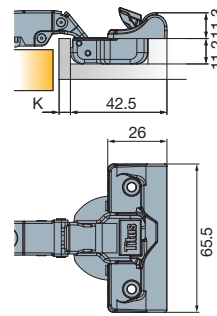
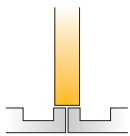

Screw-on	242-0W48-650	
----------	--------------	--

Drilling patterns for hinge cups → see page 2.15

200 Pcs

Made of steel and plastic

Mounting plates  
→ see pages 2.123-2.128



Cover caps for hinge arm  
→ see page 2.173



Hinge cup screws  
If not pre-mounted

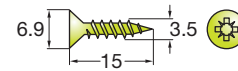

820-6308-050

10000 Pcs

Hinge angle restrictor  
→ see page 2.171



TouchControl Solutions  
→ see pages 2.193-2.204



Door adjustment

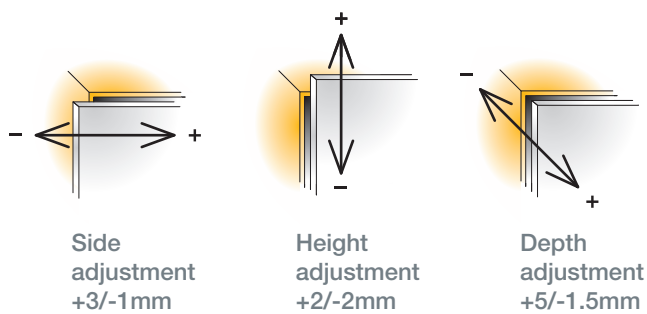

For further explanation → see pages 2.20-2.22

Mounting details

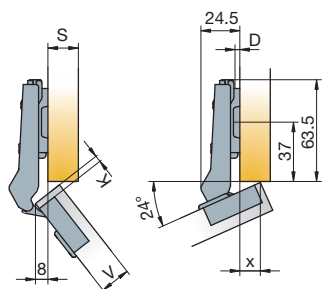

Mounting plate drilling distance

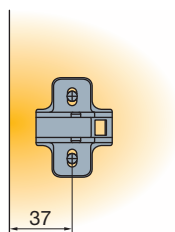

Mounting plate thickness table

For further explanation → see page 2.11

X	3	4	5	9	10	11	12	13	14
3	9			3	2	1	0		
K	4	9			3	2	1	0	
5			9			3	2	1	0

Drawings show application on D=0mm mounting plate

Door clearance

For further explanation → see page 2.12



V	16	17	18	19	20	21	22	
3	0.3	0.5	0.7	1.0	1.3	1.7	2.5	
K	4	0.3	0.5	0.7	0.9	1.2	1.6	2.1
5	0.3	0.5	0.7	0.9	1.2	1.5	2.0	F <sub>MIN</sub>

Gap Z<sub>MIN</sub>=0

# S-type-i3 110/30°

30° angled application for wood doors

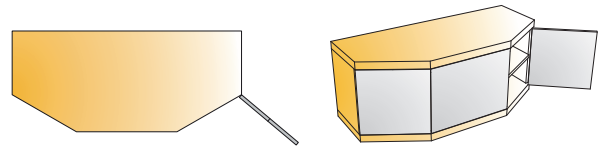
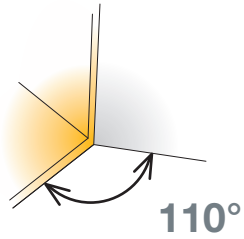

- Opening angle
- Drilling diameter for hinge cup
- Drilling depth
- Hinge on plate mounting system

110°  
35mm  
min. 11mm  
snap-on



Technical details

	Interaxis 45mm	Interaxis 48mm
Cup type		
Item number	242-0885-650	242-0886-650
Screw-on	●	●

Cranking  
9mm

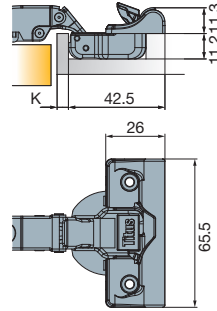
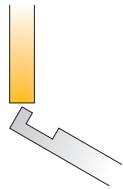

Drilling patterns for hinge cups → see page 2.15

100 Pcs

Cup made of steel and plastic, arm made of zinc

Mounting plates

→ see pages 2.123-2.128



Cover caps for hinge arm

→ see page 2.173



Hinge cup screws

If not pre-mounted

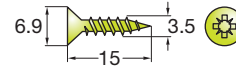

820-6308-050

10000 Pcs

Hinge angle restrictor

→ see page 2.171



TouchControl Solutions

→ see pages 2.193-2.204



Door adjustment

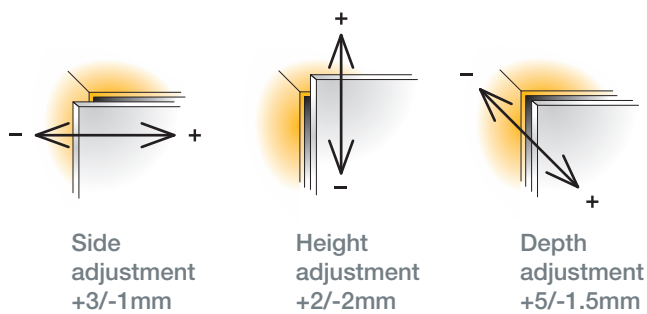

For further explanation → see pages 2.20-2.22

Mounting details

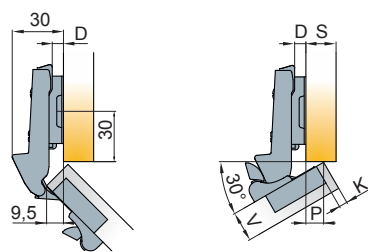

Mounting plate drilling distance

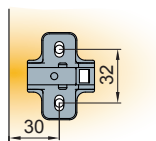

Mounting plate thickness table

For further explanation → see page 2.11

P	2.5	3.5	4.5	8.5	9.5	10.5	11.5	12.5	13.5
3	9			3	2	1	0		
K 4		9			3	2	1	0	
5			9			3	2	1	0 D

Drawings show application on D=3mm mounting plate

Door clearance

For further explanation → see page 2.12

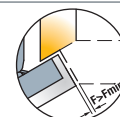

V	16	17	18	19	20	21	22
3	0.3	0.5	0.7	1.0	1.3	1.7	2.5
K 4	0.3	0.5	0.7	0.9	1.2	1.6	2.1
5	0.3	0.5	0.7	0.9	1.2	1.5	2.0 F <sub>MIN</sub>

Gap Z<sub>MIN</sub>=0

# S-type-i3 110/45°

45° angled application for wood doors

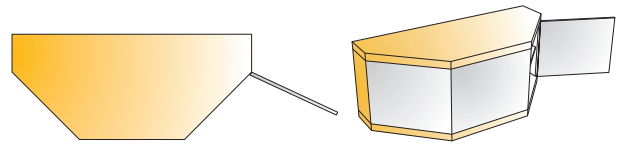
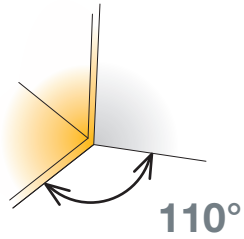

- Opening angle
  - Drilling diameter for hinge cup
  - Drilling depth
  - Hinge on plate mounting system
- 110°  
35mm  
min. 11mm  
snap-on



Technical details

Cup type	Interaxis 45mm	Interaxis 48mm
	Item number	Item number

Cranking  
9mm

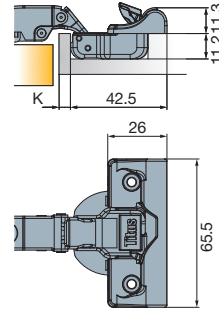
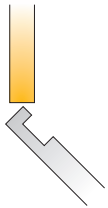

	242-0P81-650	242-0824-650
--	--------------	--------------

Drilling patterns for hinge cups → see page 2.15

100 Pcs

Cup made of steel and plastic, arm made of zinc

Cranking  
18mm

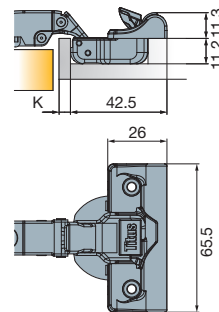
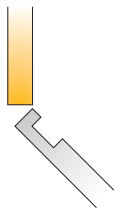

	242-0G76-650	242-0H17-650
--	--------------	--------------

Drilling patterns for hinge cups → see page 2.15

100 Pcs

Cup made of steel and plastic, arm made of zinc

Mounting plates  
→ see pages 2.123-2.128



Cover caps for hinge arm  
→ see page 2.173



Hinge cup screws  
If not pre-mounted

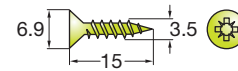

820-6308-050

10000 Pcs

Hinge angle restrictor  
→ see page 2.171



TouchControl Solutions  
→ see pages 2.193-2.204



Door adjustment

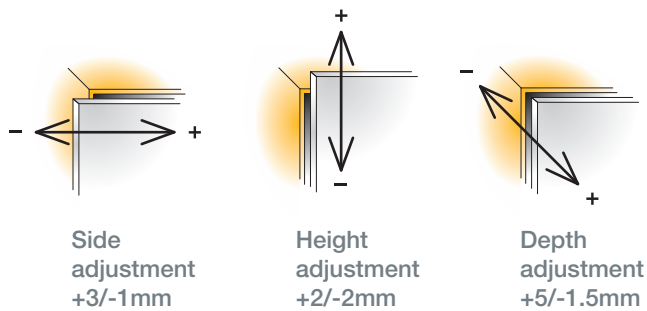

For further explanation → see pages 2.20-2.22

Mounting details

Mounting plate drilling distance

Mounting plate thickness table  
For further explanation → see page 2.11

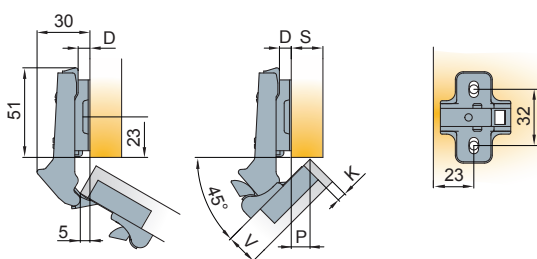

P	9	9.5	10	10.5	11	11.5	12	12.5	13.5
3	3		2		1		0		
K 4		3		2		1		0	
5				3		2		1	0 D

Drawing show application on D=3mm mounting plate

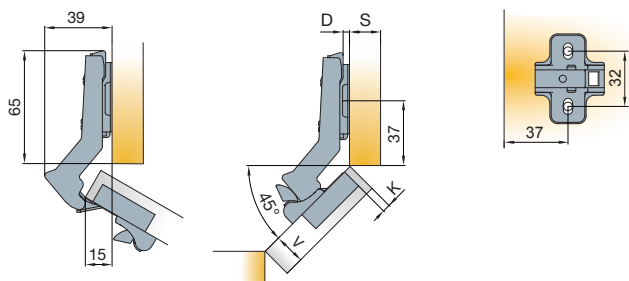

K	3	4	5
	0	1	2 D

Drawing shows application on D=0mm mounting plate

Door clearance

For further explanation → see page 2.12

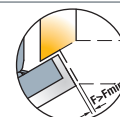

V	16	17	18	19	20	21	22
3	0.3	0.5	0.7	1.0	1.3	1.7	2.5
K 4	0.3	0.5	0.7	0.9	1.2	1.6	2.1
5	0.3	0.5	0.7	0.9	1.2	1.5	2.0 F <sub>MIN</sub>

Gap Z<sub>MIN</sub>=0

# S-type-i3 110/90°

For wood door cabinets with blind panels

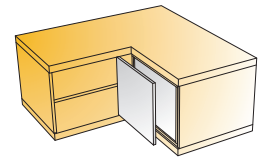
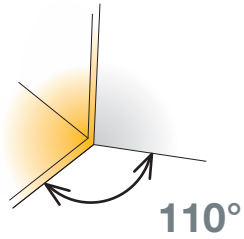

- Opening angle
- Drilling diameter for hinge cup
- Drilling depth
- Hinge on plate mounting system

110°  
35mm  
min. 11mm  
snap-on



Technical details

	Interaxis 45mm	Interaxis 48mm
Cup type		
Item number	242-0Y45-650	242-0Y46-650
Screw-on		

Cranking  
18mm

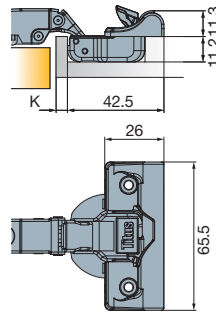
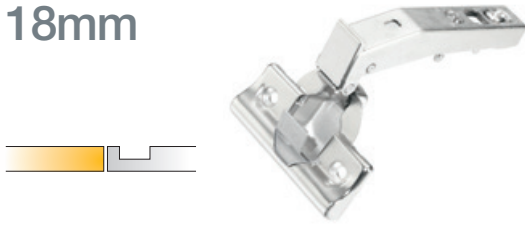

Drilling patterns for hinge cups → see page 2.15

100 Pcs

Cup made of steel and plastic, arm made of zinc

Mounting plates  
→ see pages 2.123-2.128



Cover caps for hinge arm  
→ see page 2.173



Hinge cup screws  
If not pre-mounted

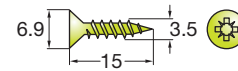

820-6308-050

10000 Pcs

Hinge angle restrictor  
→ see page 2.171



TouchControl Solutions  
→ see pages 2.193-2.204



Door adjustment

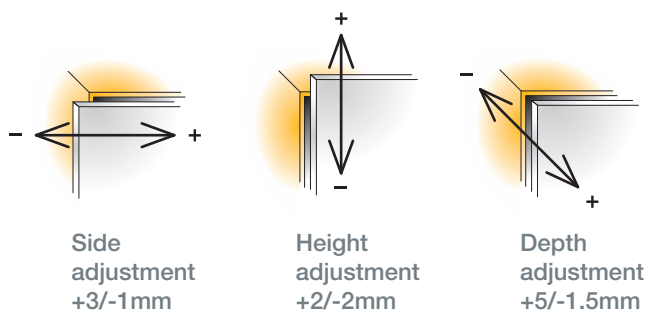

For further explanation → see pages 2.20-2.22

Mounting details

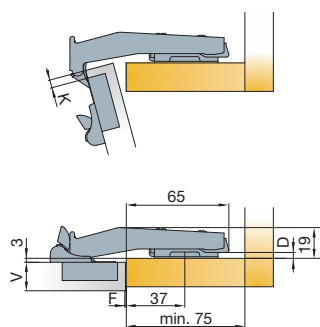

Drawings show application on D=0mm mounting plate

Mounting plate drilling distance

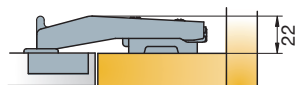
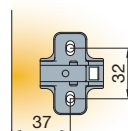

Drawing shows application on D=3mm mounting plate  
Door aligned with blind panel

Door clearance

For further explanation → see page 2.12

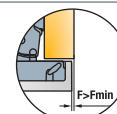

V	16	17	18	19	20	21	22	
3	0.3	0.5	0.7	1.0	1.3	1.7	2.5	
K	4	0.3	0.5	0.7	0.9	1.2	1.6	2.1
	5	0.3	0.5	0.7	0.9	1.2	1.5	2.0

Gap Z<sub>MIN</sub>=0

# S-type 110

For wood doors

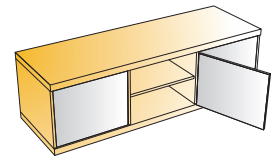
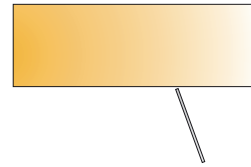
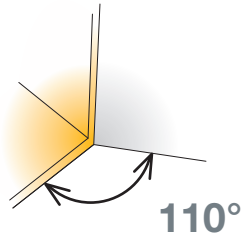

- Opening angle
- Drilling diameter for hinge cup
- Drilling depth
- Hinge on plate mounting system

110°  
35mm  
11.5mm  
snap-on



Technical details

Cup type	Interaxis 45mm	Interaxis 48mm
	Item number	Item number

Cranking  
0mm



200 Pcs

Made of steel

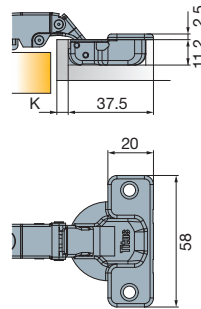

	248-0535-050	248-0532-050
	248-0171-050	248-0172-050
	248-0186-050	248-0188-050
Drilling patterns for hinge cups → see page 2.15		

Cranking  
9mm

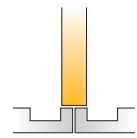

200 Pcs

Made of steel

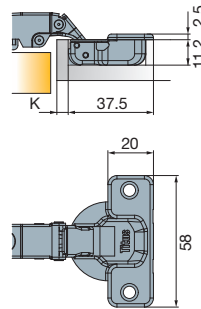

	248-0536-050	248-0533-050
	248-0279-050	248-0327-050
	248-0482-050	248-0545-050
Drilling patterns for hinge cups → see page 2.15		

Cranking  
15mm

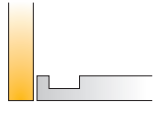

200 Pcs

Made of steel

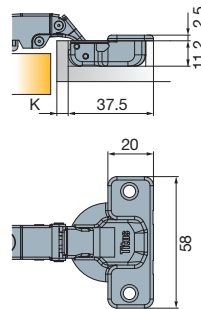

	248-0537-050	248-0534-050
	248-0280-050	248-0328-050
	248-0487-050	248-0547-050
Drilling patterns for hinge cups → see page 2.15		

Mounting plates  
→ see pages 2.123-2.128



Cover caps for hinge arm  
→ see page 2.173



Hinge cup screws  
If not pre-mounted

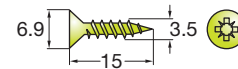

820-6308-050  
10000 Pcs

Hinge angle restrictor  
→ see page 2.171



TouchControl Solutions  
→ see pages 2.193-2.204



Soft closing systems  
→ see pages 2.183-2.190



Door adjustment

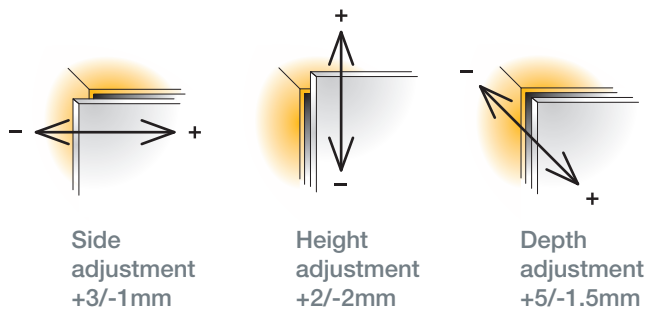

For further explanation → see pages 2.20-2.22

Mounting details

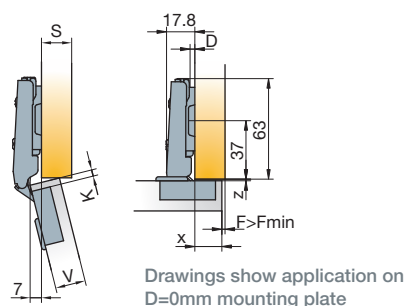

Mounting plate drilling distance

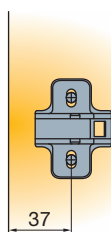

Mounting plate thickness table

For further explanation → see page 2.11

X	13	14	15	16	17	18
3	3	2	1	0		
K	4	3	2	1	0	
5			3	2	1	0

$D=13+K-X$

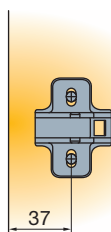
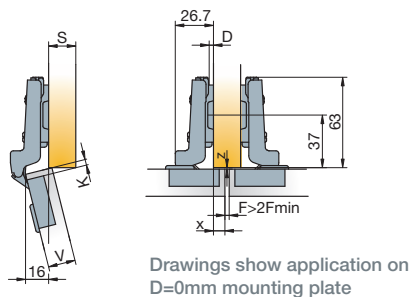

X	4	5	6	7	8	9
3	3	2	1	0		
K	4	3	2	1	0	
5			3	2	1	0

$D=4+K-X$

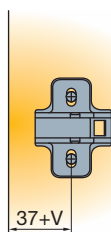
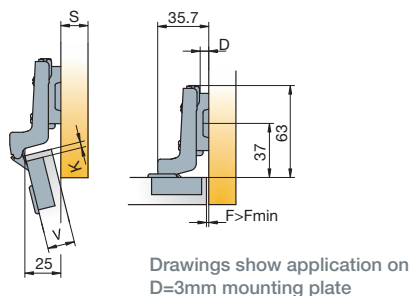

V	16	17	18	19	20	21
3	2	2	2	3	3	3
K	4	3	3			
5	3					

$D=-2+K-F$

Door clearance

For further explanation → see page 2.12

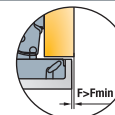

V	16	17	18	19	20	21	22
3	0.3	0.5	0.7	1.0	1.3	1.7	2.5
K	4	0.3	0.5	0.7	0.9	1.2	1.6
5	0.3	0.5	0.7	0.9	1.2	1.5	2.0

Gap  $Z_{MIN}=0$

# S-type 110/-15°

-15° angled application for wood doors

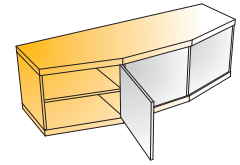
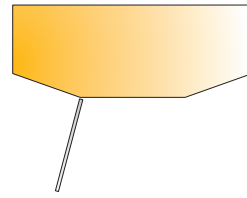
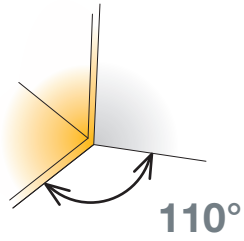

- Opening angle
- Drilling diameter for hinge cup
- Drilling depth
- Hinge on plate mounting system

110°  
35mm  
11.5mm  
snap-on



Technical details

Cup type	Interaxis 45mm	Interaxis 48mm
Item number	Item number	Item number
Screw-on	248-0V14-050	248-0V39-050
Machine insertion	248-0V41-050	248-0V42-050

Drilling patterns for hinge cups → see page 2.15

Cranking  
0mm

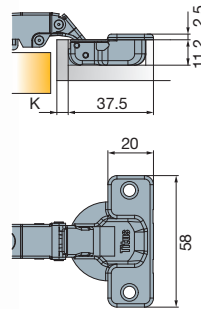
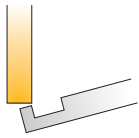

100 Pcs

Cup made of steel, arm made of zinc

### Mounting plates

→ see pages 2.123-2.128



### Cover caps for hinge arm

→ see page 2.173



### Hinge cup screws

If not pre-mounted

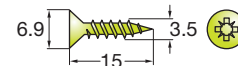

820-6308-050

10000 Pcs

### Hinge angle restrictor

→ see page 2.171



### TouchControl Solutions

→ see pages 2.193-2.204



Door adjustment

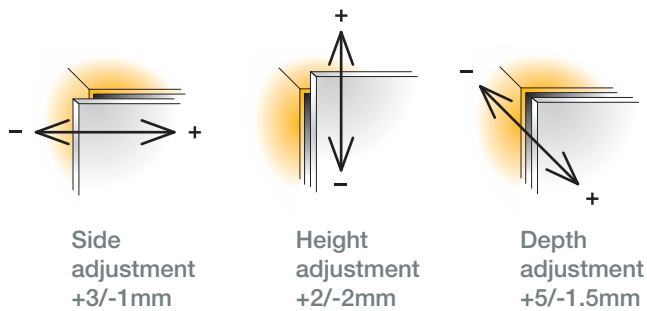

For further explanation → see pages 2.20-2.22

Mounting details

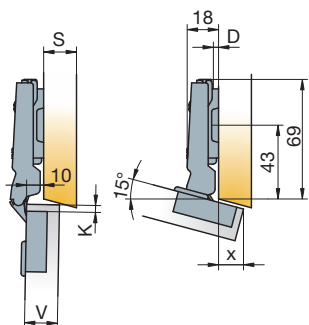

Mounting plate drilling distance

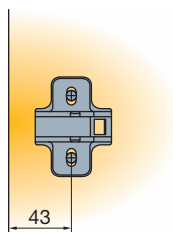

Mounting plate thickness table

For further explanation → see page 2.11

X	4	5	6	10	11	12	13	14	15
3	9			3	2	1	0		
K 4		9			3	2	1	0	
5			9			3	2	1	0

Drawings show application on D=0mm mounting plate

Door clearance

For further explanation → see page 2.12

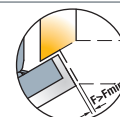

V	16	17	18	19	20	21	22
3	0.3	0.5	0.7	1.0	1.3	1.7	2.5
K 4	0.3	0.5	0.7	0.9	1.2	1.6	2.1
5	0.3	0.5	0.7	0.9	1.2	1.5	2.0

Gap Z<sub>MIN</sub>=0

# S-type 110/15°

15° angled application for wood doors

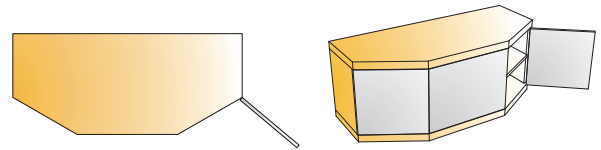
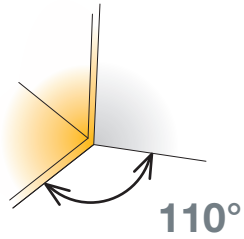

- Opening angle 110°
- Drilling diameter for hinge cup 35mm
- Drilling depth 11.5mm
- Hinge on plate mounting system snap-on



Technical details

Cup type	Interaxis 45mm	Interaxis 48mm
	Item number 248-0080-050	Item number 248-0V62-050
	Screw-on	

Cranking  
9mm

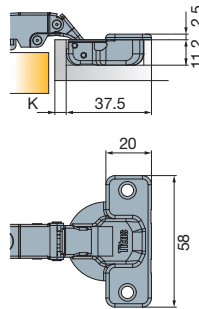
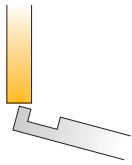

Drilling patterns for hinge cups → see page 2.15



100 Pcs

Cup made of steel, arm made of zinc

**Mounting plates**

→ see pages 2.123-2.128



**Cover caps for hinge arm**

→ see page 2.173



**Hinge cup screws**

If not pre-mounted

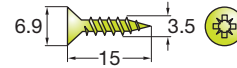

820-6308-050

10000 Pcs

**Hinge angle restrictor**

→ see page 2.171



**TouchControl Solutions**

→ see pages 2.193-2.204



**Soft closing systems**

→ see pages 2.183-2.190



Door adjustment

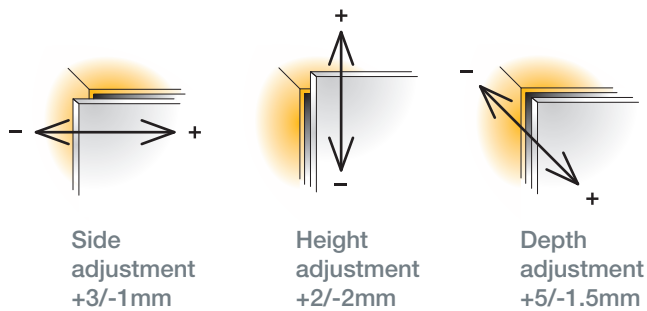

For further explanation → see pages 2.20-2.22

Mounting details

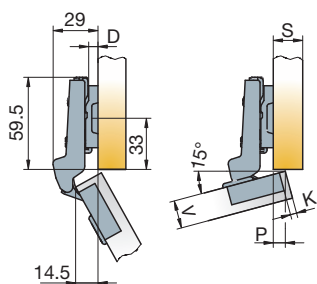

Drawings show application on D=0 and K=4mm mounting plate

Mounting plate drilling distance

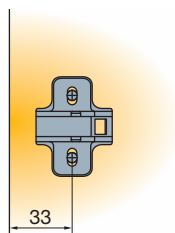

Mounting plate thickness table

For further explanation → see page 2.11

X, P	1	2	3	7	8	9	10	11	12
3	9			3	2	1	0		
K 4		9			3	2	1	0	
5			9			3	2	1	0 D

Door clearance

For further explanation → see page 2.12

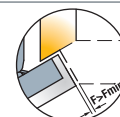

V	16	17	18	19	20	21	22
3	0.3	0.5	0.7	1.0	1.3	1.7	2.5
K 4	0.3	0.5	0.7	0.9	1.2	1.6	2.1
5	0.3	0.5	0.7	0.9	1.2	1.5	2.0 F <sub>MIN</sub>

Gap Z<sub>MIN</sub>=0

# S-type 110/24°

24° angled application for wood doors

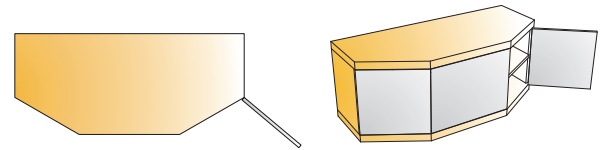
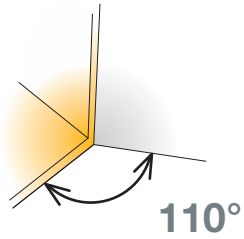

- Opening angle 110°
- Drilling diameter for hinge cup 35mm
- Drilling depth 11.5mm
- Hinge on plate mounting system snap-on



Technical details

Cup type	Interaxis 45mm	Interaxis 48mm
	Item number	Item number
	248-0V18-050	248-0V45-050
	248-0V47-050	248-0V48-050

Cranking  
9mm

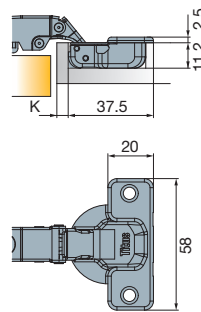
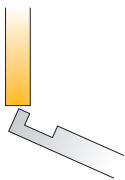

Drilling patterns for hinge cups → see page 2.15

100 Pcs

Cup made of steel, arm made of zinc

Mounting plates  
→ see pages 2.123-2.128



Cover caps for hinge arm  
→ see page 2.173



Hinge cup screws  
If not pre-mounted

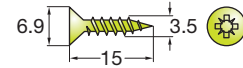

820-6308-050  
 10000 Pcs

Hinge angle restrictor  
→ see page 2.171



TouchControl Solutions  
→ see pages 2.193-2.204



Soft closing systems  
→ see pages 2.183-2.190



Door adjustment

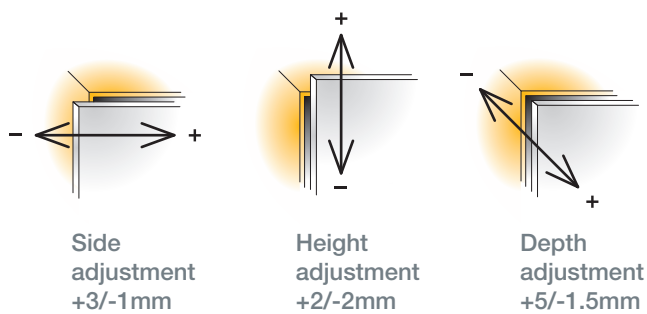

For further explanation → see pages 2.20-2.22

Mounting details

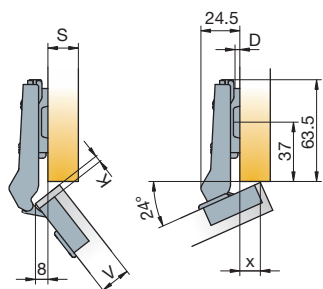

Mounting plate drilling distance

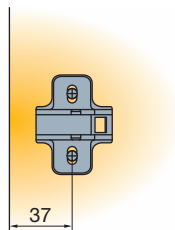

Mounting plate thickness table

For further explanation → see page 2.11

X	3	4	5	9	10	11	12	13	14
3	9			3	2	1	0		
K 4		9			3	2	1	0	
5			9			3	2	1	0 D

Drawings show application on D=0mm mounting plate

Door clearance

For further explanation → see page 2.12

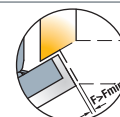

V	16	17	18	19	20	21	22
3	0.3	0.5	0.7	1.0	1.3	1.7	2.5
K 4	0.3	0.5	0.7	0.9	1.2	1.6	2.1
5	0.3	0.5	0.7	0.9	1.2	1.5	2.0 F <sub>MIN</sub>

Gap Z<sub>MIN</sub>=0

# S-type 110/30°

30° angled application for wood doors

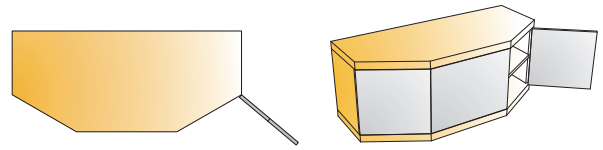
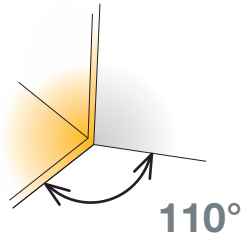

- Opening angle 110°
- Drilling diameter for hinge cup 35mm
- Drilling depth 11.5mm
- Hinge on plate mounting system snap-on



Technical details

Cup type	Interaxis 45mm	Interaxis 48mm
	Item number	Item number
	248-0675-050	248-0665-050
	248-0N12-050	248-0N13-050

Cranking  
9mm

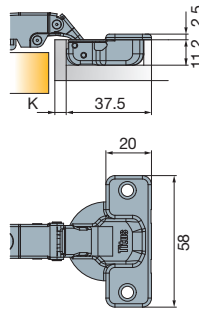
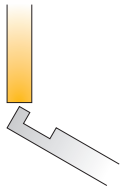

Drilling patterns for hinge cups → see page 2.15

200 Pcs

Cup made of steel, arm made of zinc

Mounting plates  
→ see pages 2.123-2.128



Cover caps for hinge arm  
→ see page 2.173



Hinge cup screws  
If not pre-mounted

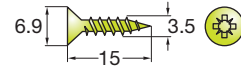

820-6308-050

10000 Pcs

Hinge angle restrictor  
→ see page 2.171



TouchControl Solutions  
→ see pages 2.193-2.204



Soft closing systems  
→ see pages 2.183-2.190



Door adjustment

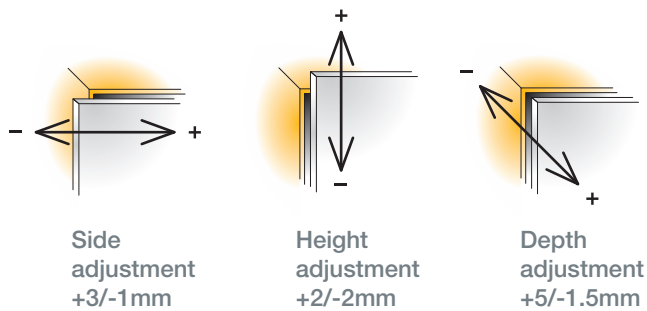

For further explanation → see pages 2.20-2.22

Mounting details

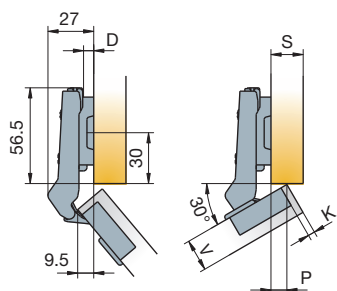

Drawings show application on D=3mm mounting plate

Mounting plate drilling distance

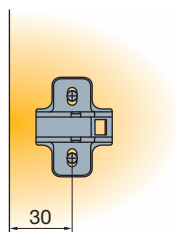

Mounting plate thickness table

For further explanation → see page 2.11

P	2.5	3.5	4.5	8.5	9.5	10.5	11.5	12.5	13.5
3	9			3	2	1	0		
K 4		9			3	2	1	0	
5			9			3	2	1	0 D

Door clearance

For further explanation → see page 2.12

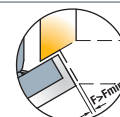

V	16	17	18	19	20	21	22
3	0.3	0.5	0.7	1.0	1.3	1.7	2.5
K 4	0.3	0.5	0.7	0.9	1.2	1.6	2.1
5	0.3	0.5	0.7	0.9	1.2	1.5	2.0 F <sub>MIN</sub>

Gap Z<sub>MIN</sub>=0

# S-type 110/45°

45° angled application for wood doors

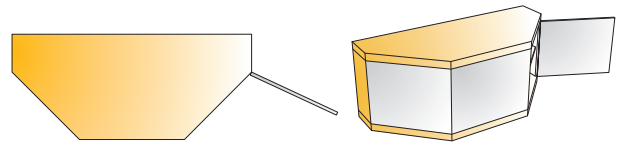
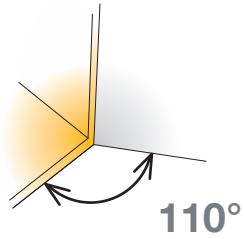

- Opening angle 110°
- Drilling diameter for hinge cup 35mm
- Drilling depth 11.5mm
- Hinge on plate mounting system snap-on



Technical details

Cup type	Interaxis 45mm	Interaxis 48mm
	Item number	Item number

Cranking 9mm

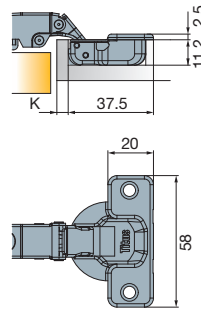
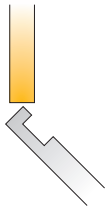

	248-0433-050	248-0431-050
	248-0N16-050	248-0N17-050

Drilling patterns for hinge cups → see page 2.15

200 Pcs

Cup made of steel, arm made of zinc

Cranking 18mm

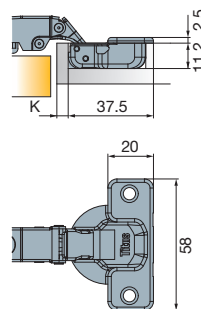
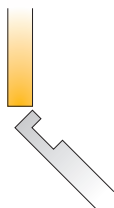

	248-0285-050	248-0283-050
	248-0N20-050	248-0N21-050

Drilling patterns for hinge cups → see page 2.15

200 Pcs

Cup made of steel, arm made of zinc

Mounting plates  
→ see pages 2.123-2.128



Cover caps for hinge arm  
→ see page 2.173



Hinge cup screws  
If not pre-mounted

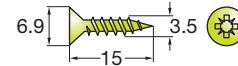

820-6308-050  
 10000 Pcs

Hinge angle restrictor  
→ see page 2.171



TouchControl Solutions  
→ see pages 2.193-2.204



Soft closing systems  
→ see pages 2.183-2.190



Door adjustment

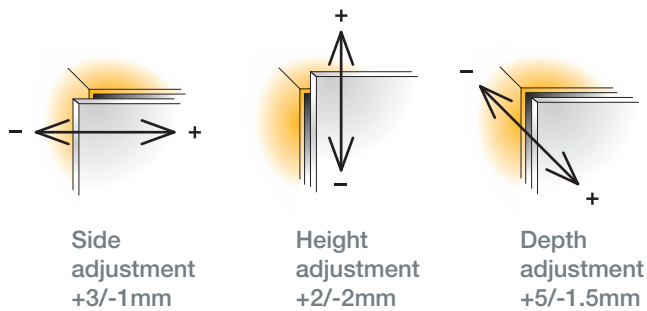

For further explanation → see pages 2.20-2.22

Mounting details

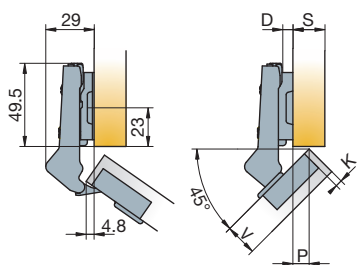

Mounting plate drilling distance

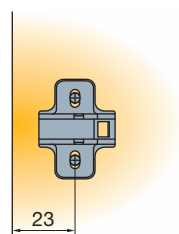

Mounting plate thickness table

For further explanation → see page 2.11

P	9	9.5	10	10.5	11	11.5	12	12.5	13.5
3	3		2		1		0		
K 4		3		2		1		0	
5				3		2		1	0

**D**

Drawings show application on D=3mm mounting plate

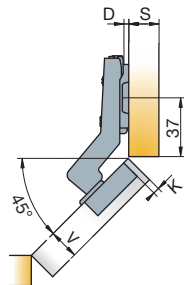
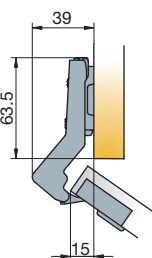

K	3	4	5
	0	1	2

**D**

Drawings show application on D=0mm mounting plate

Drawing shows application on D=0mm mounting plate

Door clearance

For further explanation → see page 2.12

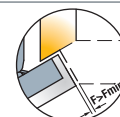

V	16	17	18	19	20	21	22
3	0.3	0.5	0.7	1.0	1.3	1.7	2.5
K 4	0.3	0.5	0.7	0.9	1.2	1.6	2.1
5	0.3	0.5	0.7	0.9	1.2	1.5	2.0

**F<sub>MIN</sub>**

Gap Z<sub>MIN</sub>=0

# S-type 110/90°

For wood door cabinets with blind panels

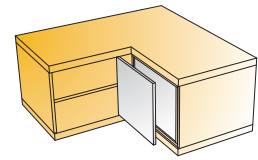
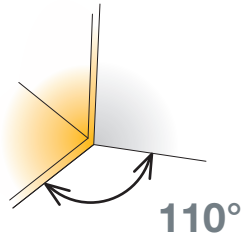

- Opening angle 110°
- Drilling diameter for hinge cup 35mm
- Drilling depth 11.5mm
- Hinge on plate mounting system snap-on



Technical details

Cup type	Interaxis 45mm	Interaxis 48mm
Item number	Item number	Item number
Screw-on	248-0745-050	248-0742-050
Machine insertion	248-0N24-050	248-0N25-050
EasyFix	248-0L61-050	248-0N62-050

Cranking  
18mm

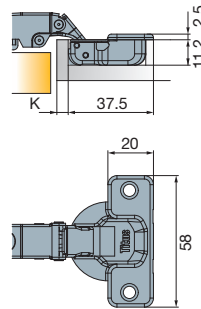

Drilling patterns for hinge cups → see page 2.15

100 Pcs

Cup made of steel, arm made of zinc

Mounting plates  
→ see pages 2.123-2.128



Cover caps for hinge arm  
→ see page 2.173



Hinge cup screws  
If not pre-mounted

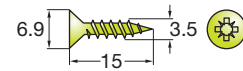

820-6308-050

10000 Pcs

Hinge angle restrictor  
→ see page 2.171



TouchControl Solutions  
→ see pages 2.193-2.204



Soft closing systems  
→ see pages 2.183-2.190



Door adjustment

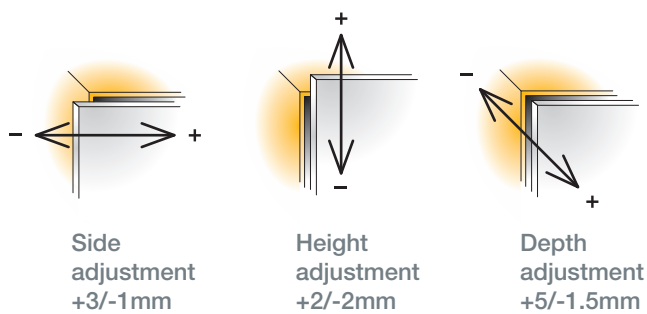

For further explanation → see pages 2.20-2.22

Mounting details

Mounting plate drilling distance

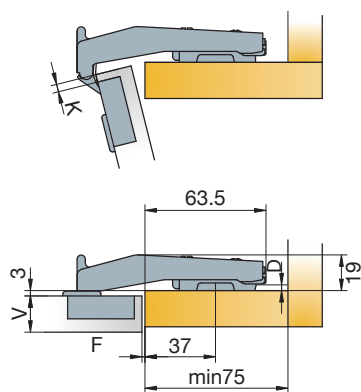

Drawings show application on D=0mm mounting plate

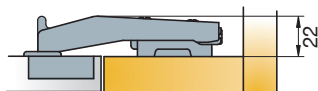

Drawing shows application on D=3mm mounting plate  
Door aligned with blind panel

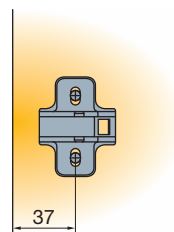

Door clearance

For further explanation → see page 2.12

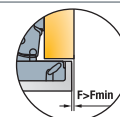

V	16	17	18	19	20	21	22
3	0.3	0.5	0.7	1.0	1.3	1.7	2.5
K 4	0.3	0.5	0.7	0.9	1.2	1.6	2.1
5	0.3	0.5	0.7	0.9	1.2	1.5	2.0

Gap Z<sub>MIN</sub>=0

# S-type 110 AL

For aluminium frame doors

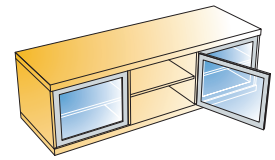
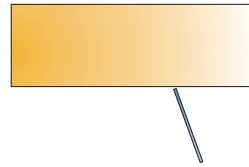
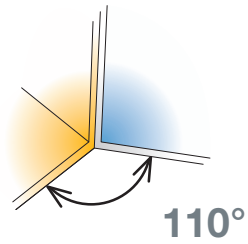

- Opening angle
- Hinge on plate mounting system

110°  
snap-on



Interaxis  
**28mm**

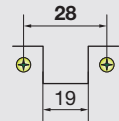

Cup type

Item number

Cranking  
**0mm**



200 Pcs

Cup made of zinc, arm made of steel



**950-0T27-050**

\* Screws included

Cranking  
**9mm**



200 Pcs

Cup made of zinc, arm made of steel



**950-0T50-050**

\* Screws included

Cranking  
**15mm**

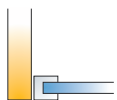

200 Pcs

Cup made of zinc, arm made of steel



**950-0T52-050**

\* Screws included

Mounting plates  
→ see pages 2.123-2.128



Cover caps for hinge arm  
→ see page 2.173



Hinge cup screws  
If not pre-mounted

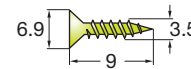

**820-6350-050**

10000 Pcs

TouchControl Solutions  
→ see pages 2.193-2.204



· Can be combined with PushOpen mechanisms without housing

Door adjustment

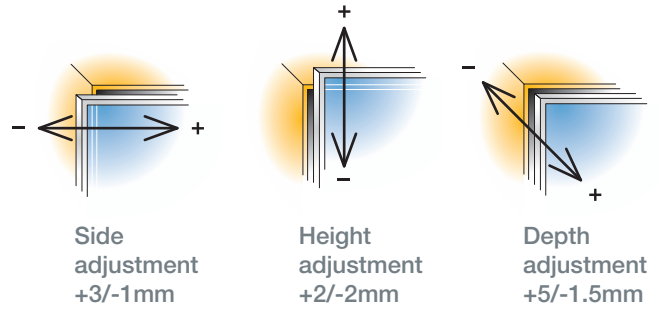

For further explanation → see pages 2.20-2.22

Mounting details

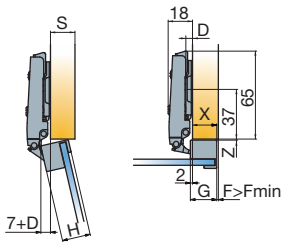

Drawings show application on D=0mm mounting plate

Mounting plate drilling distance

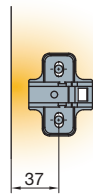

Mounting plate thickness table

For further explanation → see page 2.11

X	12	13	14	15	16	17	18
17	3	2	1	0			
18		3	2	1	0		
19			3	2	1	0	
20				3	2	1	0

**D**

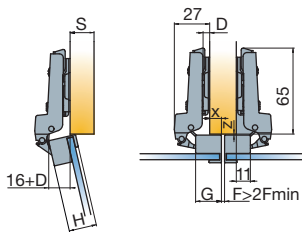

Drawings show application on D=0mm mounting plate

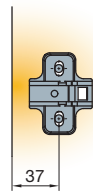

X	3	4	5	6	7	8	9
17	3	2	1	0			
18		3	2	1	0		
19			3	2	1	0	
20				3	2	1	0

**D**

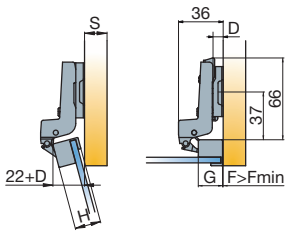

Drawings show application on D=3mm mounting plate

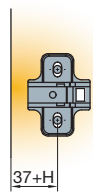

H	17	18	19	20	21	22
17	1	1	2	2	2	3
18	2	2	3	3	3	3
19	3	3	3	3		
20	3	3				

**D**

Drilling pattern for aluminium frame hinges

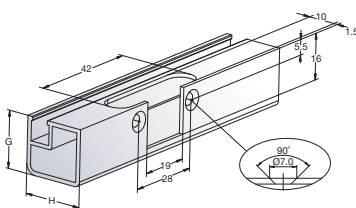

Mounting details

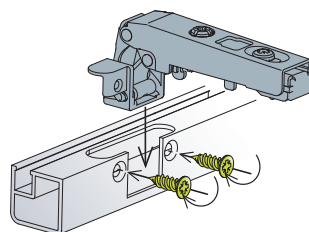

Screws included

Door clearance

For further explanation → see page 2.12

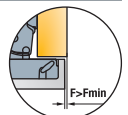

H	17	18	19	20	21	22
17	0.5	0.7	1.1	1.4	1.8	2.9
18	0.5	0.7	1.0	1.3	1.7	2.5
19	0.5	0.7	0.9	1.2	1.6	2.1
20	0.5	0.7	0.9	1.2	1.5	2.0

**F<sub>MIN</sub>**

Gap Z<sub>MIN</sub>=0.5

# S-type 110 Unsprung Hinge

For wood doors

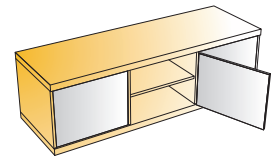
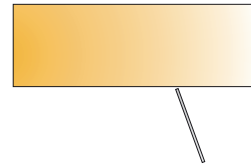
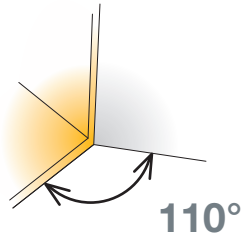

- Opening angle
- Drilling diameter for hinge cup
- Drilling depth
- Hinge on plate mounting system

110°  
35mm  
11.5mm  
snap-on



Technical details

Cup type	Interaxis 45mm	Interaxis 48mm
Item number		

Cranking  
0mm

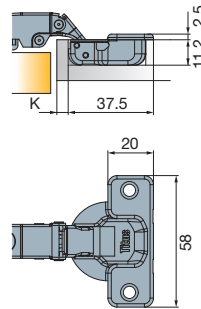

Screw-on	248-0AW6-050	248-0AW8-050
----------	--------------	--------------

Drilling patterns for hinge cups → see page 2.15

200 Pcs

Made of steel

Cranking  
9mm

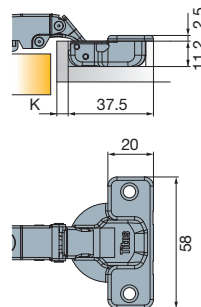
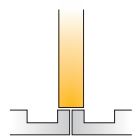

Screw-on	248-0395-050	248-0AW9-050
----------	--------------	--------------

Drilling patterns for hinge cups → see page 2.15

200 Pcs

Made of steel

Mounting plates  
→ see pages 2.123-2.128



Cover caps for hinge arm  
→ see page 2.173



Hinge cup screws  
If not pre-mounted

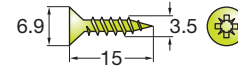

820-6308-050

10000 Pcs

Hinge angle restrictor  
→ see page 2.171



TouchControl Solutions  
→ see pages 2.193-2.204



- Hinge without spring
- Effortless opening with just a light touch
- Use with PushOpen mechanisms with magnet

→ see pages 2.197-2.200



Touch

Door adjustment

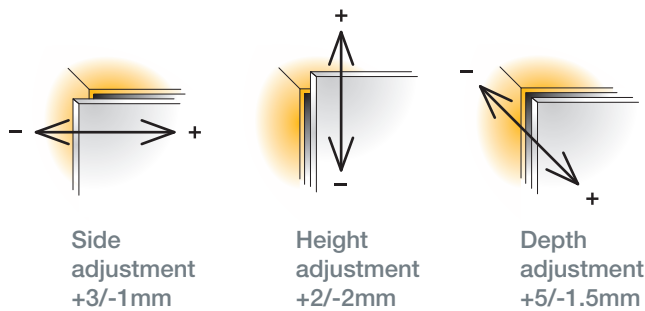

For further explanation → see pages 2.20-2.22

Mounting details

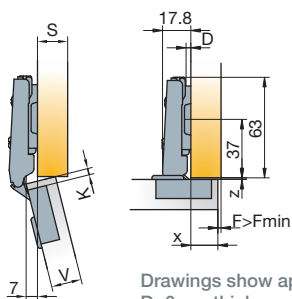

Drawings show application on D=0mm thick mounting plate

Mounting plate drilling distance

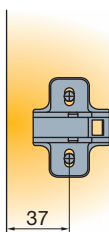

Mounting plate thickness table

For further explanation → see pages 2.13

X	13	14	15	16	17	18
3	3	2	1	0		
K	4	3	2	1	0	
5		3	2	1	0	D

$D=13+K-x$

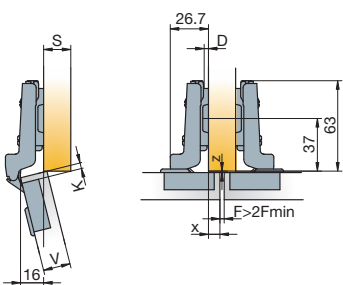

Drawings show application on D=0mm thick mounting plate

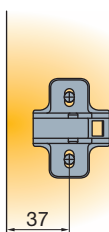

X	4	5	6	7	8	9
3	3	2	1	0		
K	4	3	2	1	0	
5		3	2	1	0	D

$D=4+K-x$

Door clearance at R=1mm

For further explanation → see pages 2.14

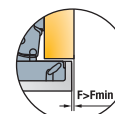

V	16	17	18	19	20	21	22	
3	0.3	0.5	0.7	1.0	1.3	1.7	2.5	
K	4	0.3	0.5	0.7	0.9	1.2	1.6	2.1
5	0.3	0.5	0.7	0.9	1.2	1.5	2.0	F <sub>MIN</sub>

Gap Z<sub>MIN</sub>=0

# S-type 170

For wood doors

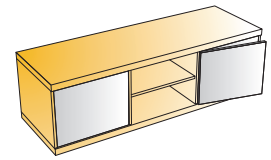
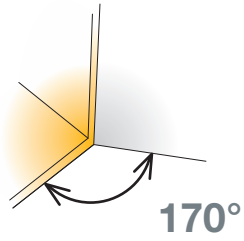

- Opening angle
- Drilling diameter for hinge cup
- Drilling depth
- Hinge on plate mounting system

170°  
35mm  
12mm  
snap-on

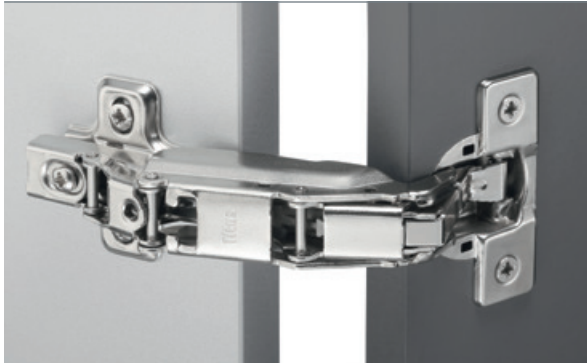

Technical details

Cup type	Interaxis 45mm	Interaxis 48mm
	Item number	Item number
	248-0R14-050	248-0R17-050
	248-0M73-050	248-0R13-050

Drilling patterns for hinge cups → see page 2.15

Cranking  
0mm

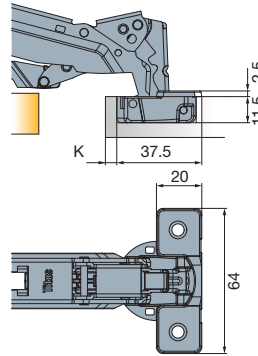
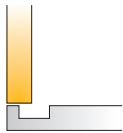

50 Pcs

Made of steel and zinc

Mounting plates  
→ see pages 2.123-2.128



Hinge cup screws  
If not pre-mounted

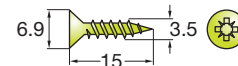

820-6308-050

10000 Pcs

Hinge angle restrictor  
→ see page 2.171



TouchControl Solutions  
→ see pages 2.193-2.204



Soft closing systems  
→ see page 2.185



Zero protrusion  
with D=0 mounting plate

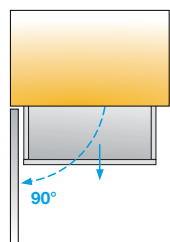

Door adjustment

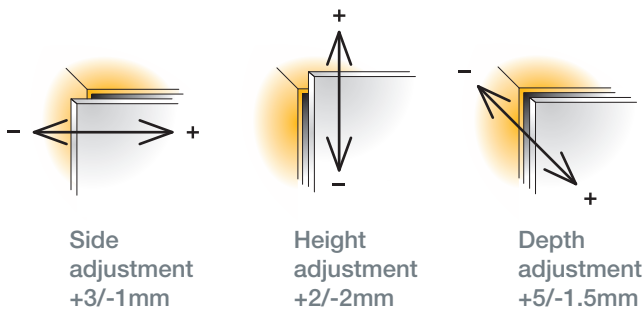

For further explanation → see pages 2.20-2.22

Mounting  
details

Mounting plate  
drilling distance

Mounting plate thickness table  
For further explanation → see page 2.11

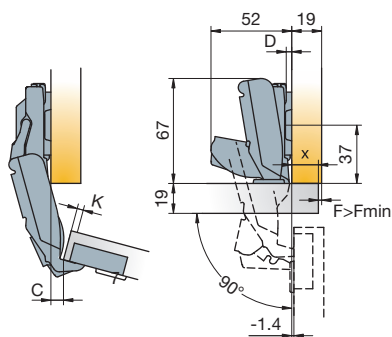

Drawings show application on  
D=0mm mounting plate  
No protrusion in 90° position

X 10 11 12 13 14 15 16 17 18 19 20

	3	6		3	2	1	0													
	4		6			3	2	1	0											
K	5			6			3	2	1	0										
	6				6			3	2	1	0									
	7					6			3	2	1	0								D

$D=13+K-X$

C value with D=0 mounting plates

K	3	4	5	6	7	
	-9.0	-8.1	-7.1	-6.1	-5.2	C

Door clearance

For further explanation → see page 2.12



V 16 17 18 19 20 21 22 23 24

	3	0.0	0.0	0.0	0.0	0.0	0.0	0.0	0.0	0.0	0.0	0.0	0.0	0.0	0.0	0.0	0.0	0.0	0.0	0.0
	4	0.0	0.0	0.0	0.0	0.0	0.0	0.0	0.0	0.0	0.0	0.0	0.0	0.0	0.0	0.0	0.0	0.0	0.0	0.0
K	5	0.0	0.0	0.0	0.0	0.0	0.0	0.0	0.0	0.0	0.0	0.0	0.0	0.0	0.0	0.0	0.0	0.0	0.0	0.0
	6	0.0	0.0	0.0	0.0	0.0	0.0	0.0	0.0	0.0	0.0	0.0	0.0	0.0	0.0	0.0	0.0	0.0	0.0	2.6
	7	0.0	0.0	0.0	0.0	0.0	0.0	0.0	0.0	0.0	0.0	0.0	0.0	0.0	0.0	0.0	0.0	0.0	0.0	5.1 F <sub>MIN</sub>

Gap Z<sub>MIN</sub>=0.5

# S-type 170

For wood doors

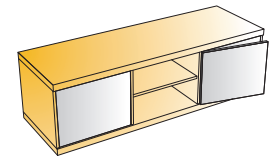
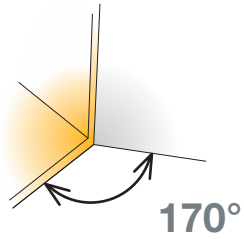

- Opening angle
- Drilling diameter for hinge cup
- Drilling depth
- Hinge on plate mounting system

170°  
35mm  
12mm  
snap-on

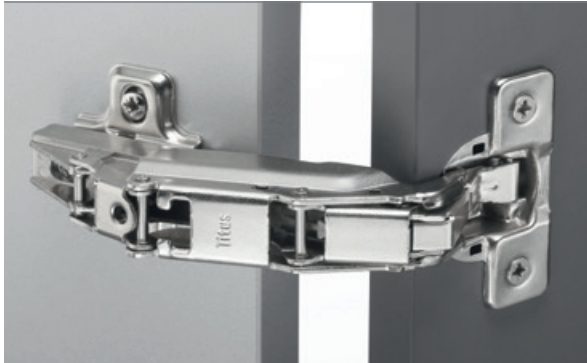

Technical details

Cup type	Interaxis 45mm	Interaxis 48mm
Item number		

Cranking  
9mm

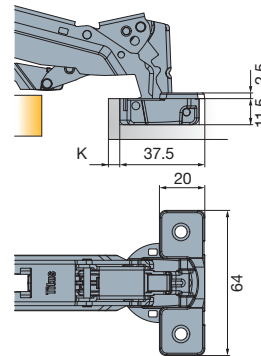
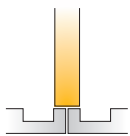

Screw-on	248-0162-050	248-0163-050
----------	--------------	--------------

Drilling patterns for hinge cups → see page 2.15

50 Pcs

Made of steel and zinc

Mounting plates  
→ see pages 2.123-2.128



Hinge cup screws  
If not pre-mounted

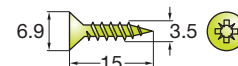

820-6308-050

10000 Pcs

Hinge angle restrictor  
→ see page 2.171



TouchControl Solutions  
→ see pages 2.193-2.204



Soft closing systems  
→ see page 2.185



Door adjustment

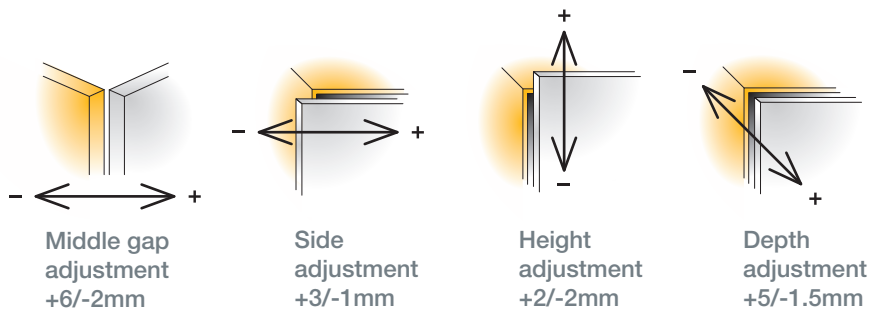

For further explanation → see pages 2.20-2.22

Mounting details

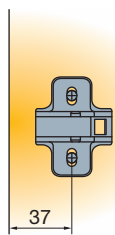
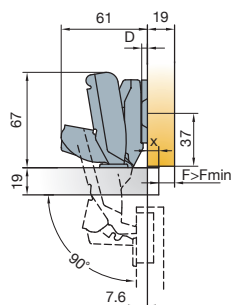
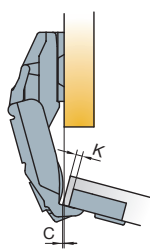

Mounting plate drilling distance

Mounting plate thickness table  
For further explanation → see page 2.11

X	1	2	3	4	5	6	7	8	9	10	11
3	6			3	2	1	0				
4		6			3	2	1	0			
K 5			6			3	2	1	0		
6				6			3	2	1	0	
7					6			3	2	1	0

$D=4+K-X$

C value with D=0 mounting plates

K	3	4	5	6	7	
C	0	0.9	1.9	2.9	3.8	D

Drawings show application on D=0mm mounting plate

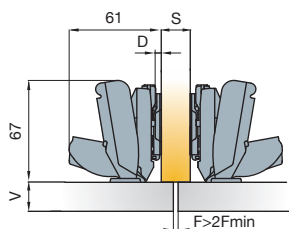

Drawing shows application on D=0mm mounting plate

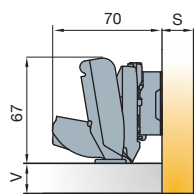

Drawing shows application on D=9mm mounting plate

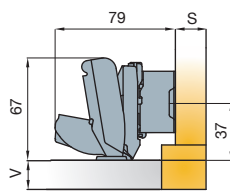

Drawing shows application on D=18mm mounting plate

Door clearance  
For further explanation → see page 2.12

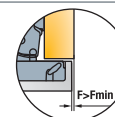

V	16	17	18	19	20	21	22	23	24
3	0.0	0.0	0.0	0.0	0.0	0.0	0.0	0.0	0.0
4	0.0	0.0	0.0	0.0	0.0	0.0	0.0	0.0	0.0
K 5	0.0	0.0	0.0	0.0	0.0	0.0	0.0	0.0	0.0
6	0.0	0.0	0.0	0.0	0.0	0.0	0.0	0.0	2.6
7	0.0	0.0	0.0	0.0	0.0	0.0	0.0	0.0	5.1 F <sub>MIN</sub>

Gap Z<sub>MIN</sub>=0.5

# S-type for Pie-cut Corner Cabinet

For wood doors

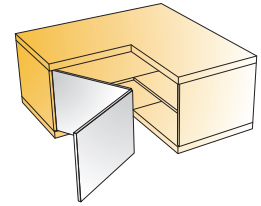

- Opening angle 90°
- Drilling diameter for hinge cup 35mm
- Drilling depth 11.5mm
- Hinge on plate mounting system snap-on



Technical details

	Interaxis 45mm	Interaxis 48mm
Cup type		
Item number	248-0U21-050	248-0U16-050
	Screw-on	248-0U16-050
	Machine insertion	248-0V15-050

Drilling patterns for hinge cups → see page 2.15

Corner cabinet

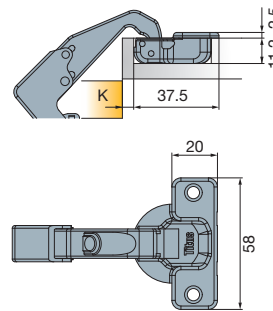
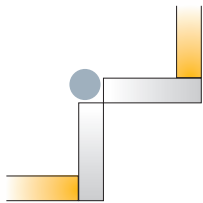

100 Pcs

Cup made of steel, arm made of zinc

### Mounting plates

→ see pages 2.123-2.128



### Cover caps for hinge arm

→ see page 2.173



### Hinge cup screws

If not pre-mounted

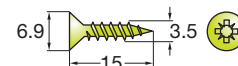

820-6308-050

10000 Pcs

### TouchControl Solutions

→ see pages 2.193-2.204



· Use in pair with 170° hinge

Door adjustment

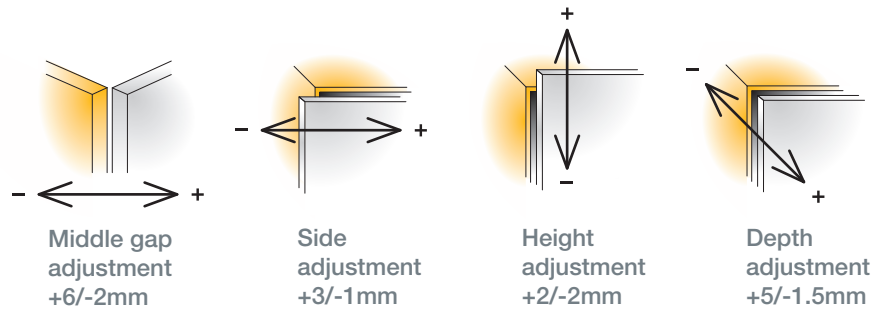

For further explanation → see pages 2.20-2.22

Mounting details

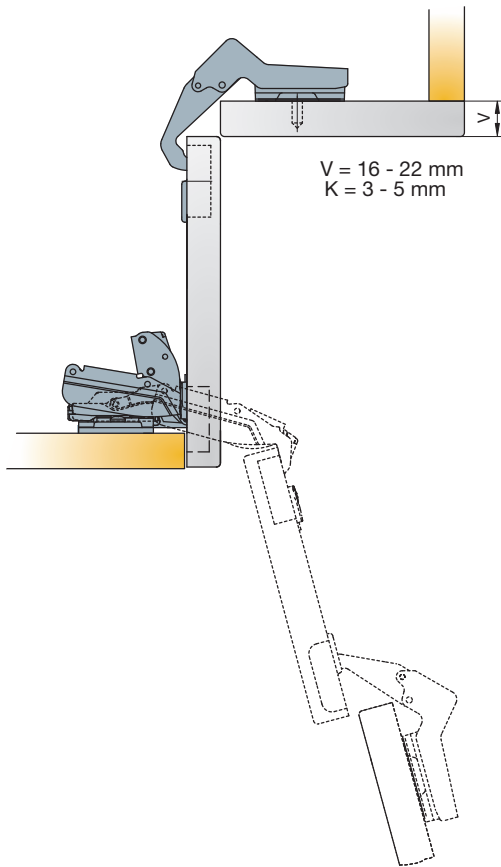

Mounting plate drilling distance

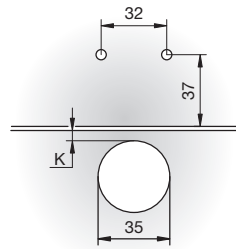

Adjustments

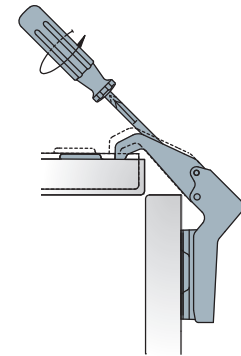

The diagonal adjustment is made by rotating the appropriate screw as shown on the drawing

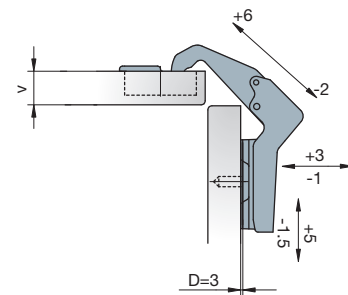

Drawing shows application on D=3mm mounting plate

# S-type Mounting Plates

## S-type snap-on mounting

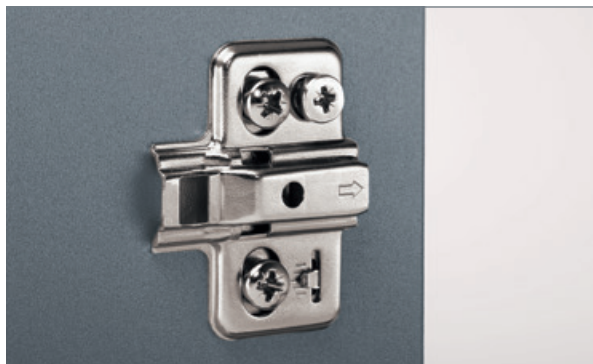
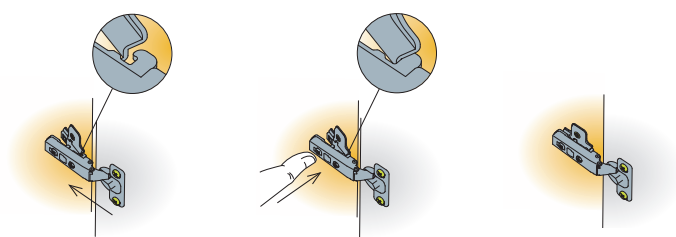

Cam adjustable cruciform  
mounting plate 37mm

Drilling pattern

Dimensions

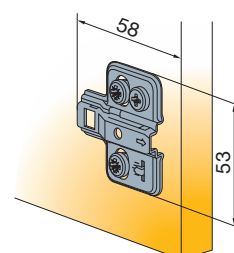
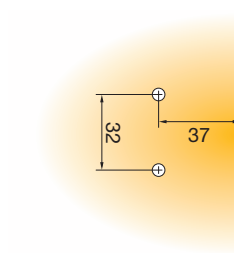

 200 Pcs    Made of steel

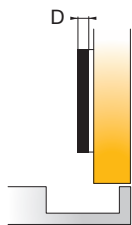

Mounting plate thickness

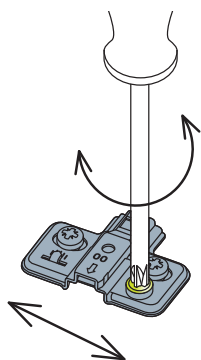

Height adjustment +/- 2mm

Mounting plate type	13	15	15	10.5	10.5	
Mounting plate thickness (D)						
	Item number	Item number	Item number	Item number	Item number	
0mm	244-0258-050	244-0261-050	*244-0264-050	*244-0342-050	244-0270-050	
2mm	244-0259-050	244-0262-050	*244-0265-050	*244-0343-050	244-0271-050	
3mm	244-0260-050	244-0263-050	*244-0266-050	*244-0344-050	244-0272-050	

\* Available upon special request → see page 0.3

Legend of mounting plate type symbols



13

Pre-mounted  
13mm euro screws



15

Pre-mounted  
15mm euro screws



15

Pre-mounted  
chipboard screws

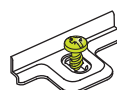

10.5

Machine  
insertion ready

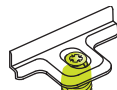

10.5

Pre-mounted  
10.5mm  
expanding dowels

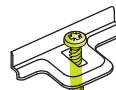

# S-type Mounting Plates

## S-type snap-on mounting

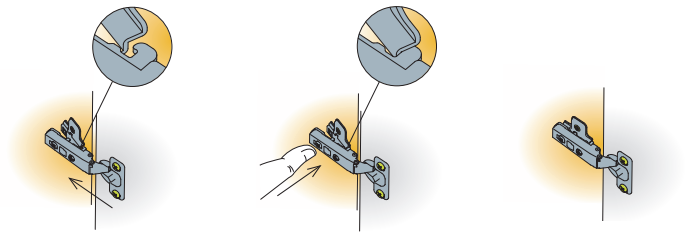

Cruciform mounting plate

Drilling pattern

Dimensions

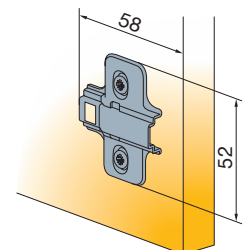
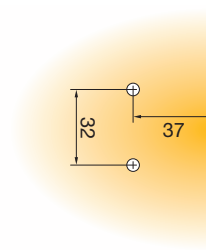

200 Pcs    Made of steel

Zinc diecast cruciform mounting plate 37mm

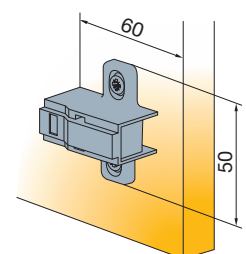
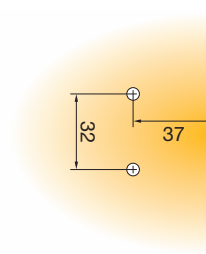

200 Pcs    Made of zinc

Fixing screws for mounting plates  
*If not pre-mounted*

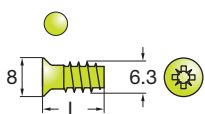

Euro screws  
821-6304-050 L=11  
821-6323-050 L=13  
821-6332-050 L=15

5000 Pcs

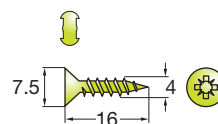

Chipboard screws  
820-6328-050

10000 Pcs



Mounting plate thickness

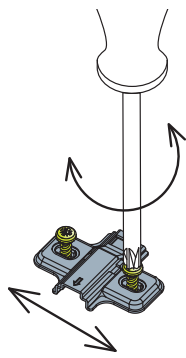

Height adjustment +/- 2mm

Mounting plate type								
Mounting plate thickness (D)								
Item number								
0mm	244-1136-050	*244-1233-050	244-0Z26-050	244-0134-050	244-0118-050	*244-0136-050	*244-0166-050	244-0P26-050
1mm	244-1137-050	*244-1228-050		244-0561-050		*244-0565-050	*244-0567-050	
2mm	244-1138-050	*244-1229-050	244-0Z63-050	244-0562-050	244-0120-050	*244-0566-050	*244-0568-050	244-0V19-050
3mm	244-1139-050	*244-1234-050		244-0135-050	244-0119-050	*244-0137-050	*244-0167-050	244-0P27-050
6mm	244-1645-050				244-0Z51-050			
<p>* Available upon special request → see page 0.3            Mounting plates with pre-mounted 7.5mm expanding dowels available upon special request → see page 0.3</p>								
9mm	244-3651-650			244-0M33-650	244-0P29-650			
18mm	244-3016-650			244-0085-650	244-0095-650			

Legend of mounting plate type symbols

Screw on ready for euro screws ← screws	Screw-on ready for chipboard ← screws	Pre-mounted 11mm euro screws	Pre-mounted 13mm euro screws	Pre-mounted 15mm euro screws	Pre-mounted chipboard screws	Machine insertion ready	Pre-mounted 10.5mm expanding dowels

# S-type

## Face Frame

### Mounting Plates

S-type snap-on mounting

Drilling pattern

Dimensions

Face frame adapter for  
S-type hinges

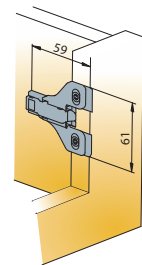
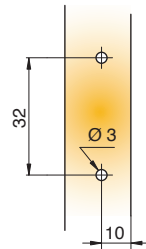

200 Pcs

Made of zinc alloy

Fixing screw for mounting plates

*If not pre-mounted*

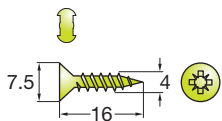

Chipboard screws  
820-6328-050



10000 Pcs



Mounting plate thickness

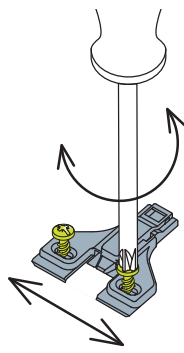

Height adjustment +/- 2mm

Mounting plate type		
		
Mounting plate thickness (D)	Item number	
0mm	244-3653-650	
3mm	244-3654-650	
6mm	244-3655-650	

Legend of mounting plate type symbols



Screw-on ready for chipboard screws  
 ← screws



# B-type Hinges

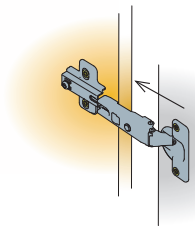

## Slide-on mounting system

- Proven and reliable hinge-to-plate mounting solution
- Cost-per-door effectiveness
- Proven solution for RTA furniture, household application and tall cabinets

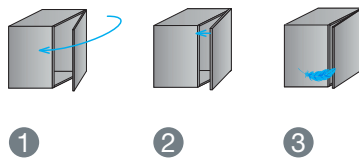

## ConfidentClose

- 1 Fast closing
- 2 Late start of deceleration action
- 3 Quiet landing with SoftTouch



## Titus Damper Inside

- Titus proprietary multi-purpose damping technology
- Reliable and consistent life-long damping

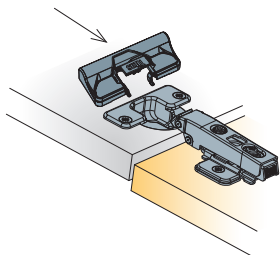
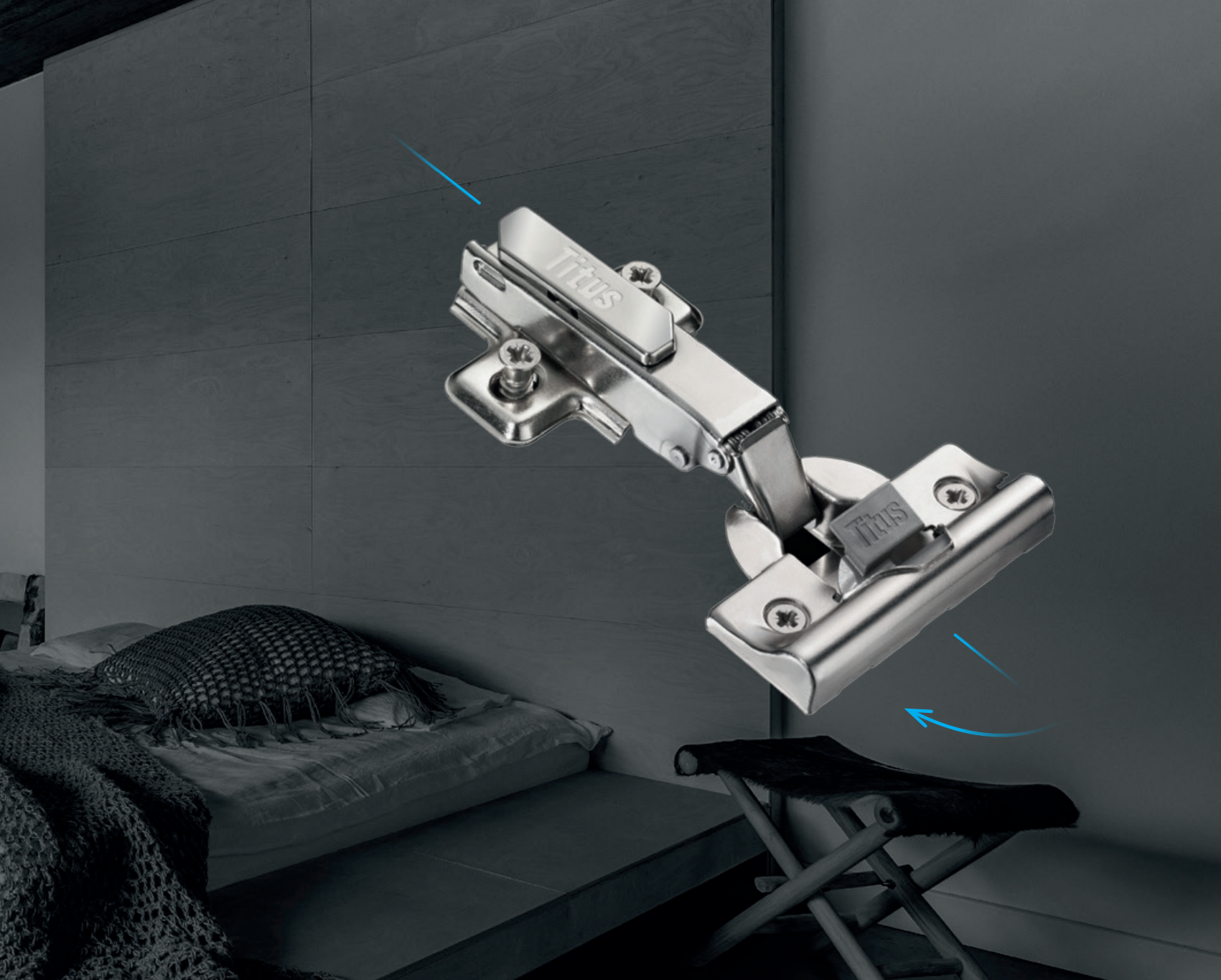

### Soft closing options

- Hinge integrated
- Stand-alone
- Add-on with Glissando ready hinge cup
- Fast and simple mounting



### B-type-i3

- Reliable open-close
- Consistent performance
- ConfidentClose
- Low 11mm hinge depth cup

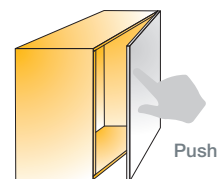

### Touch opening

- Guarantees effortless opening
- Elegant cabinet design
- Doors without handles

# B-type-i3 110

For wood doors

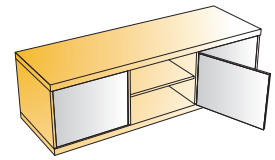
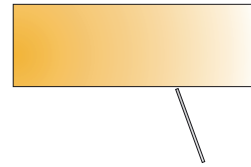
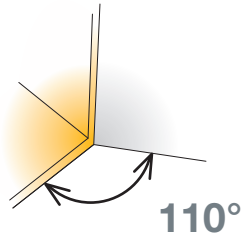

- Opening angle
- Drilling diameter for hinge cup
- Drilling depth
- Hinge on plate mounting system

110°  
35mm  
min. 11mm  
slide-on



Technical details

Cup type	Interaxis 45mm	Interaxis 48mm
Item number		

Cranking  
0mm

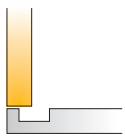

200 Pcs



Made of steel and plastic

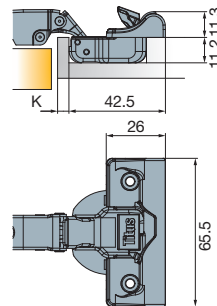

Screw-on	242-0967-054	242-0968-054
----------	--------------	--------------

Drilling patterns for hinge cups → see page 2.15

Cranking  
9mm

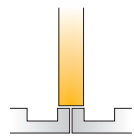

200 Pcs



Made of steel and plastic

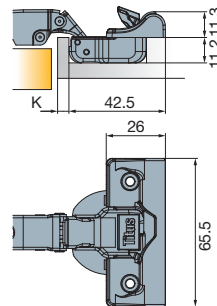

Screw-on	242-0973-054	242-0974-054
----------	--------------	--------------

Drilling patterns for hinge cups → see page 2.15

Cranking  
15mm

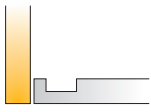

200 Pcs



Made of steel and plastic

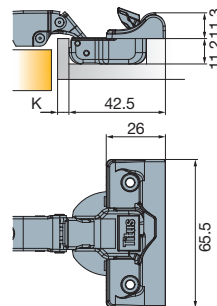

Screw-on	242-0979-054	242-0980-054
----------	--------------	--------------

Drilling patterns for hinge cups → see page 2.15

Mounting plates  
→ see pages 2.163-2.166



Cover caps for hinge arm  
→ see page 2.173



Hinge cup screws  
If not pre-mounted

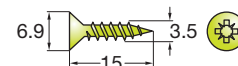

820-6308-050

10000 Pcs

Hinge angle restrictor  
→ see page 2.171



TouchControl solutions  
→ see pages 2.193-2.204



Door adjustment

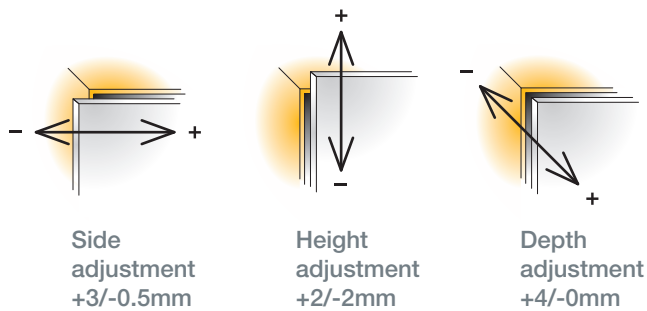

For further explanation → see pages 2.20-2.22

Mounting details

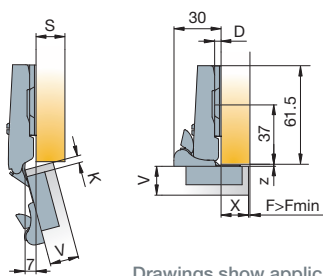

Drawings show application on D=0mm mounting plate

Mounting plate drilling distance

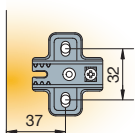

Mounting plate thickness table

For further explanation → see page 2.11

X	10	11	12	13	14	15	16	17	18
3	6	5	4	3	2	1	0	0	
K	4	6	5	4	3	2	1	0	0
5		6	5	4	3	2	1	0	D

$D=13+K-X$

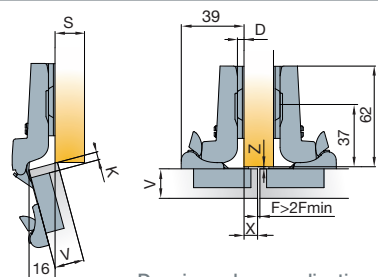

Drawings show application on D=0mm mounting plate

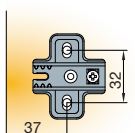

X	0	1	2	3	4	5	6	7	8	9
3		6	5	4	3	2	1	0		
K	4		6	5	4	3	2	1	0	
5	9		6	5	4	3	2	1	0	D

$D=4+K-X$

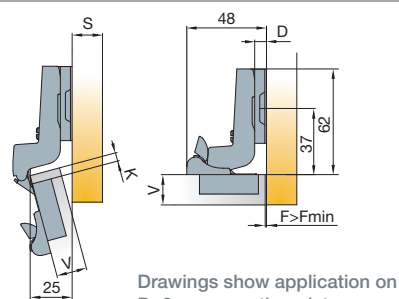

Drawings show application on D=3mm mounting plate

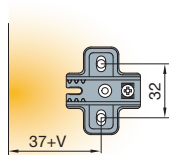

V	16	17	18	19	20	21	22
3	2	2	2	3	3	3	4
K	4	3	3	3	4	4	5
5	4	4	4	5	5	5	6

$D=-2+K+F$

Door clearance

For further explanation → see page 2.12

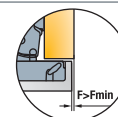

V	16	17	18	19	20	21	22
3	0.3	0.5	0.7	1.0	1.3	1.7	2.5
K	4	0.3	0.5	0.7	0.9	1.2	1.6
5	0.3	0.5	0.7	0.9	1.2	1.5	2.0

Gap  $Z_{MIN}=0$

# B-type-i3 110/30°

30° angled application for wood doors

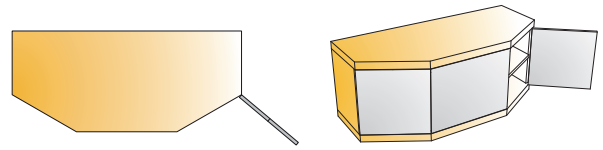
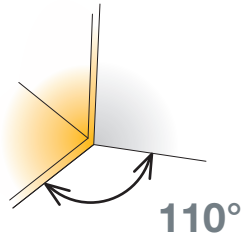

- Opening angle
- Drilling diameter for hinge cup
- Drilling depth
- Hinge on plate mounting system

110°  
35mm  
min. 11mm  
slide-on



Technical details

Cup type	Interaxis 45mm	Interaxis 48mm
Item number	242-0924-650	242-0H34-650
Screw-on		

Cranking  
9mm

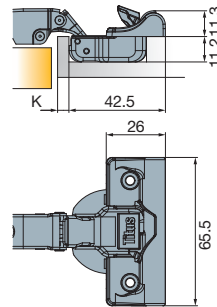
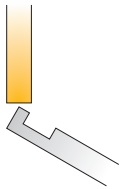

Drilling patterns for hinge cups → see page 2.15



100 Pcs

Cup made of steel and plastic, arm made of zinc

## Mounting plates

→ see pages 2.163-2.166



## Cover caps for hinge arm

→ see page 2.173



## Hinge cup screws

If not pre-mounted

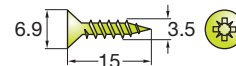

820-6308-050

10000 Pcs

## Hinge angle restrictor

→ see page 2.171



## TouchControl solutions

→ see pages 2.193-2.204



Door adjustment

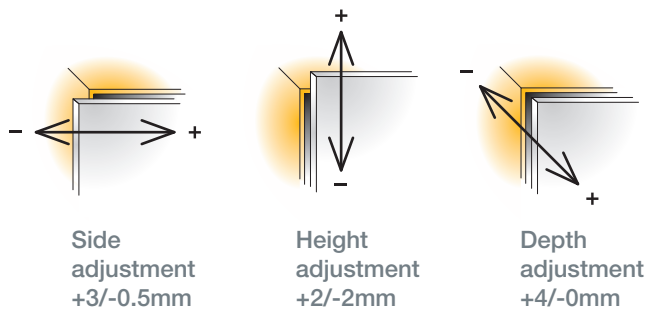

For further explanation → see pages 2.20-2.22

Mounting details

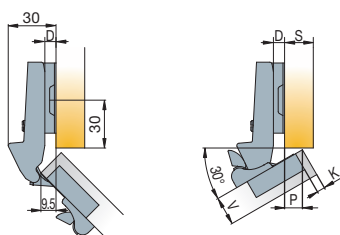

Mounting plate drilling distance

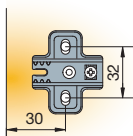

Mounting plate thickness table

For further explanation → see page 2.11

P	2.5	3.5	4.5	8.5	9.5	10.5	11.5	12.5	13.5
3	9			3	2	1	0		
K 4		9			3	2	1	0	
5			9			3	2	1	0 D

Drawings show application on D=3mm mounting plate

Door clearance

For further explanation → see page 2.12

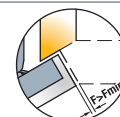

V	16	17	18	19	20	21	22
3	0.3	0.5	0.7	1.0	1.3	1.7	2.5
K 4	0.3	0.5	0.7	0.9	1.2	1.6	2.1
5	0.3	0.5	0.7	0.9	1.2	1.5	2.0 F <sub>MIN</sub>

Gap Z<sub>MIN</sub>=0

# B-type-i3 110/45°

45° angled application for wood doors

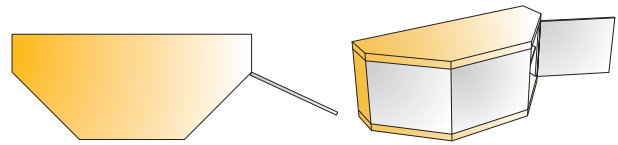
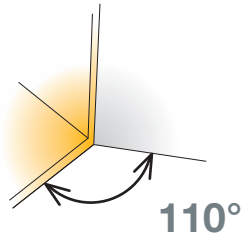

- Opening angle
- Drilling diameter for hinge cup
- Drilling depth
- Hinge on plate mounting system

110°  
35mm  
min. 11mm  
slide-on



Technical details

Cup type	Interaxis 45mm	Interaxis 48mm
	Item number	Item number
	242-0C27-650	242-0D14-650

Cranking  
9mm

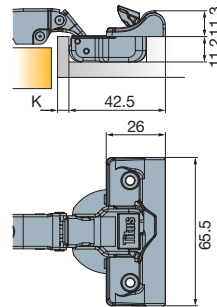
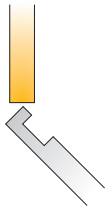

Drilling patterns for hinge cups → see page 2.15

200 Pcs

Cup made of steel and plastic, arm made of zinc

Mounting plates  
→ see pages 2.163-2.166



Cover caps for hinge arm  
→ see page 2.173



Hinge cup screws  
If not pre-mounted

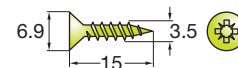

820-6308-050

10000 Pcs

Hinge angle restrictor  
→ see page 2.171



TouchControl Solutions  
→ see pages 2.193-2.204



Door adjustment

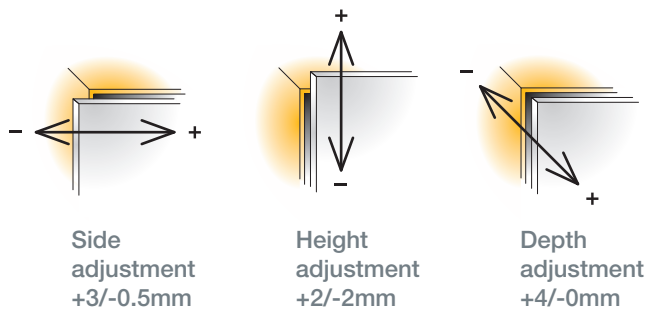

For further explanation → see pages 2.20-2.22

Mounting details

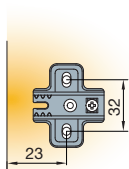
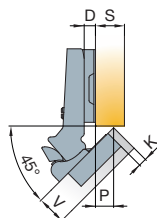
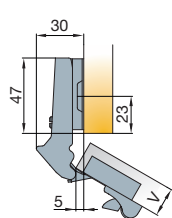

Mounting plate drilling distance

Mounting plate thickness table  
For further explanation → see page 2.11

P	9	9.5	10	10.5	11	11.5	12	12.5	13.5
3	3		2		1		0		
K	4	3		2		1		0	
5				3		2		1	0

**D**

Drawings show application on D=3mm mounting plate

Door clearance

For further explanation → see page 2.12

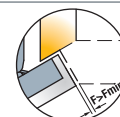

V	16	17	18	19	20	21	22	
3	0.3	0.5	0.7	1.0	1.3	1.7	2.5	
K	4	0.3	0.5	0.7	0.9	1.2	1.6	2.1
5	0.3	0.5	0.7	0.9	1.2	1.5	2.0	<b>F<sub>MIN</sub></b>

Gap Z<sub>MIN</sub>=0

# B-type-i3 110/45°

45° angled application for wood doors

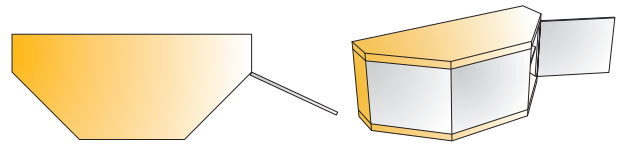
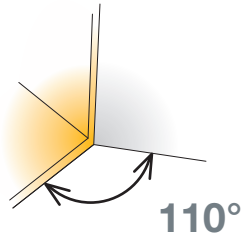

- Opening angle
- Drilling diameter for hinge cup
- Drilling depth
- Hinge on plate mounting system

110°  
35mm  
min. 11mm  
slide-on



Technical details

	Interaxis 45mm	Interaxis 48mm
Cup type		
Item number	242-0H48-650	242-0H49-650
Screw-on		

Cranking  
18mm

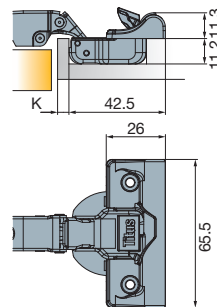
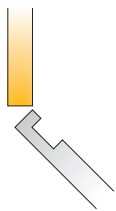

Drilling patterns for hinge cups → see page 2.15

200 Pcs

Cup made of steel and plastic, arm made of zinc

Mounting plates  
→ see pages 2.163-2.166



Cover caps for hinge arm  
→ see page 2.173



Hinge cup screws  
If not pre-mounted

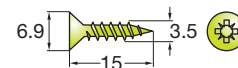

820-6308-050

10000 Pcs

Hinge angle restrictor  
→ see page 2.171



TouchControl Solutions  
→ see pages 2.193-2.204



Door adjustment

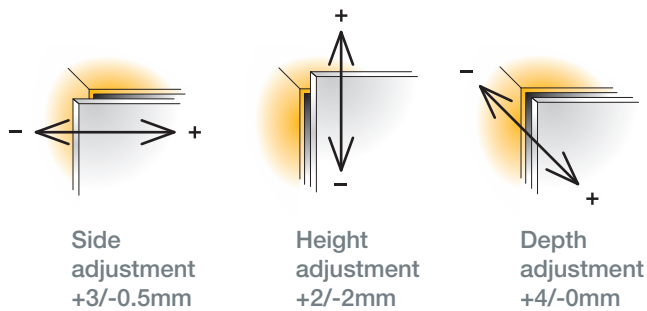

For further explanation → see pages 2.20-2.22

Mounting details

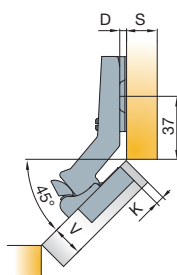
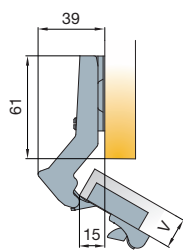

Drawing shows application on D=0mm mounting plate

Mounting plate drilling distance

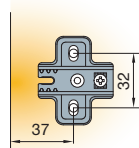

Mounting plate thickness table

For further explanation → see page 2.11

	3	0	
K	4	1	
	5	2	D

Drawings show application on D=0mm mounting plate

L=36 for thickness D=0  
 L=35 for thickness D=1  
 L=34 for thickness D=2  
 L=33 for thickness D=3

Door clearance

For further explanation → see page 2.12

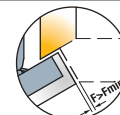

V	16	17	18	19	20	21	22	
3	0.3	0.5	0.7	1.0	1.3	1.7	2.5	
K	4	0.3	0.5	0.7	0.9	1.2	1.6	2.1
	5	0.3	0.5	0.7	0.9	1.2	1.5	2.0 F <sub>MIN</sub>

Gap Z<sub>MIN</sub>=0

# B-type-i3 110/90°

For wood door cabinets with blind panels

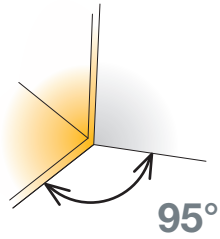
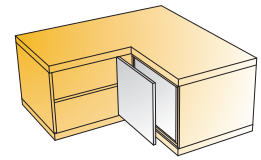

- Opening angle
- Drilling diameter for hinge cup
- Drilling depth
- Hinge on plate mounting system

95°  
35mm  
min. 11mm  
slide-on



Technical details

Cup type	Interaxis 45mm	Interaxis 48mm
Item number		

Cranking  
**18mm**

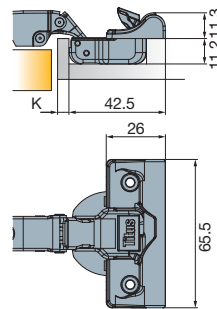

Screw-on	242-0Y48-650	242-0Y49-650
----------	--------------	--------------

Drilling patterns for hinge cups → see page 2.15

200 Pcs

Cup made of steel and plastic, arm made of zinc

Blind panel  
mounting  
plate

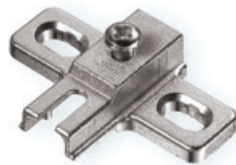

Screw-on	244-0810-650	
15	244-0P28-650	
13	244-0C32-650	

This mounting plate can be only used with B-type-i 110/90° hinges.  
Information about mounting plate symbols → see page 2.164

200 Pcs

Made of zinc

Hinge cup screws  
If not pre-mounted

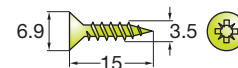

820-6308-050

10000 Pcs

Hinge angle restrictor  
→ see page 2.171



TouchControl Solutions  
→ see pages 2.193-2.204



Door adjustment

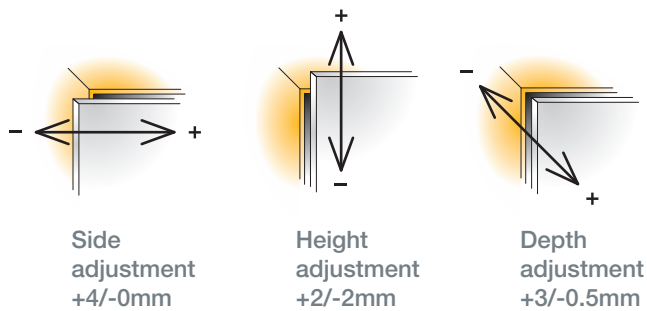

For further explanation → see pages 2.20-2.22

Mounting details

Mounting plate drilling distance

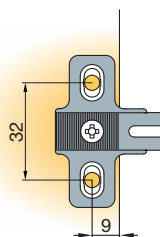
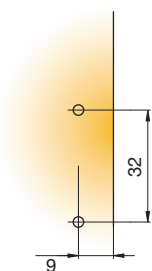
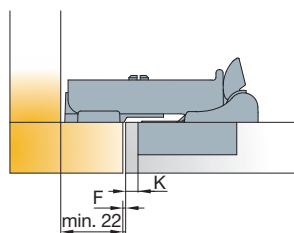

Door clearance

For further explanation → see page 2.12

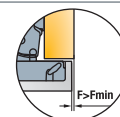

V	16	17	18	19	20	21	22	
3	0.3	0.5	0.7	1.0	1.3	1.7	2.5	
K	4	0.3	0.5	0.7	0.9	1.2	1.6	2.1
5	0.3	0.5	0.7	0.9	1.2	1.5	2.0	F <sub>MIN</sub>

Gap Z<sub>MIN</sub>=0

# B-type 110

For wood doors

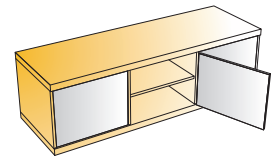
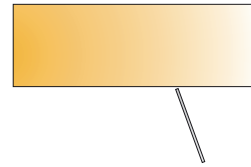
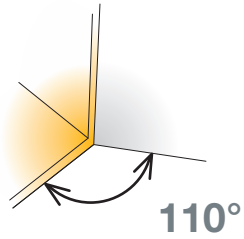

- Opening angle
- Drilling diameter for hinge cup
- Drilling depth
- Hinge on plate mounting system

110°  
35mm  
min. 11.5mm  
slide-on



Technical details

Cup type	Interaxis 45mm	Interaxis 48mm
	Item number	Item number

Cranking  
0mm



200 Pcs

Made of steel

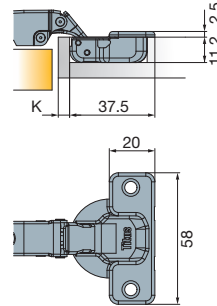

	248-0G54-050	248-0G49-050
	248-0G79-050	248-0K40-050

Drilling patterns for hinge cups → see page 2.15

Cranking  
9mm

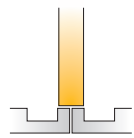

200 Pcs

Made of steel

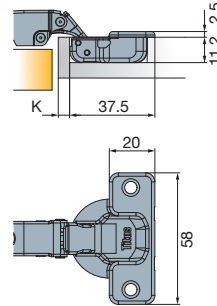

	248-0G55-050	248-0G50-050
	248-0G80-050	248-0K76-050

Drilling patterns for hinge cups → see page 2.15

Cranking  
15mm

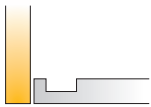

200 Pcs

Made of steel

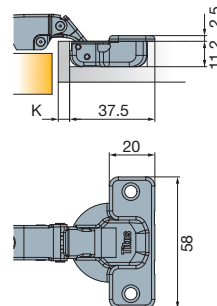

	248-0G56-050	248-0G51-050
	248-0G81-050	248-0L04-050

Drilling patterns for hinge cups → see page 2.15

Mounting plates  
→ see pages 2.163-2.166



Cover caps for hinge arm  
→ see page 2.173



Hinge cup screws  
If not pre-mounted

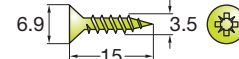

820-6308-050

10000 Pcs

Hinge angle restrictor  
→ see page 2.171



TouchControl Solutions  
→ see pages 2.193-2.204



Soft closing systems  
→ see pages 2.183-2.190



Door adjustment

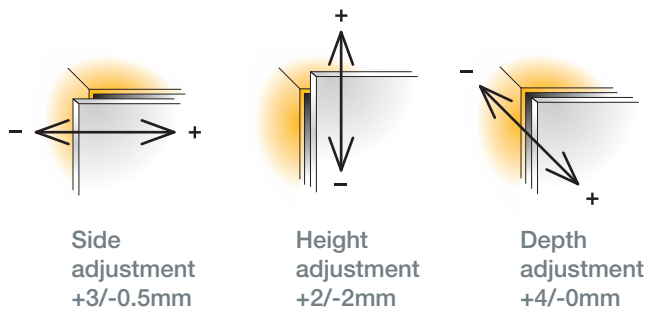

For further explanation → see pages 2.20-2.22

Mounting details

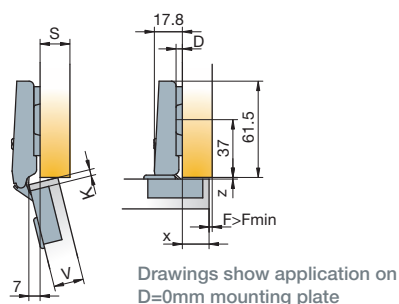

Mounting plate drilling distance

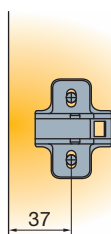

Mounting plate thickness table

For further explanation → see page 2.11

X	10	11	12	13	14	15	16	17	18
3	6	5	4	3	2	1	0	0	
K	4	6	5	4	3	2	1	0	0
5			6	5	4	3	2	1	0

$D=13+K-X$

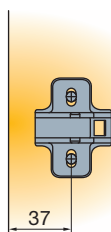
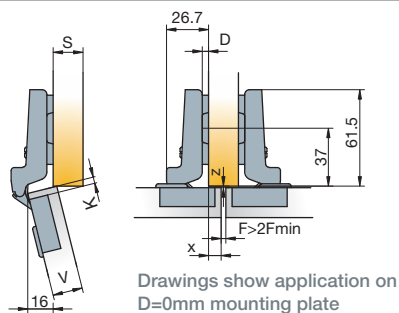

X	0	1	2	3	4	5	6	7	8	9
3		6	5	4	3	2	1	0		
K	4		6	5	4	3	2	1	0	
5	9			6	5	4	3	2	1	0

$D=4+K-X$

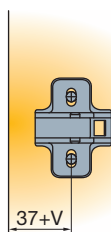
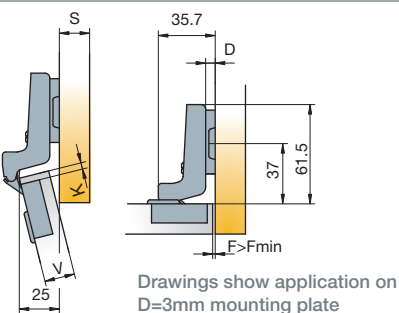

V	16	17	18	19	20	21	22
3	2	2	2	3	3	3	4
K	4	3	3	3	4	4	5
5	4	4	4	5	5	5	6

$D=-2+K+F$

Door clearance

For further explanation → see page 2.12

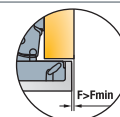

V	16	17	18	19	20	21	22
3	0.3	0.5	0.7	1.0	1.3	1.7	2.5
K	4	0.3	0.5	0.7	0.9	1.2	1.6
5	0.3	0.5	0.7	0.9	1.2	1.5	2.0

Gap  $Z_{MIN}=0$

# B-type 110/30°

30° angled application for wood doors

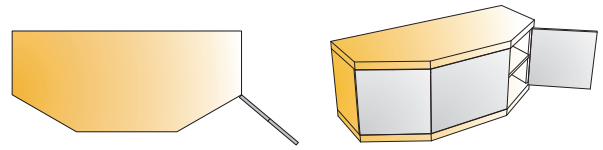
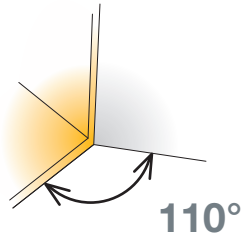

- Opening angle 110°
- Drilling diameter for hinge cup 35mm
- Drilling depth 11.5mm
- Hinge on plate mounting system slide-on



Technical details

Cup type	Interaxis 45mm	Interaxis 48mm
Item number	248-0G57-050	248-0G52-050
Item number	248-0G82-050	248-0L72-050

Cranking  
9mm

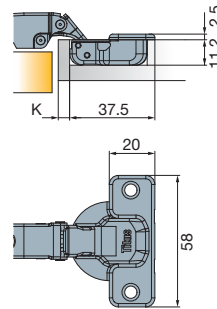
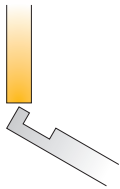

Screw-on	248-0G57-050	248-0G52-050
Machine insertion	248-0G82-050	248-0L72-050

Drilling patterns for hinge cups → see page 2.15

200 Pcs

Cup made of steel, arm made of zinc

Mounting plates  
→ see pages 2.163-2.166



Cover caps for hinge arm  
→ see page 2.173



Hinge cup screws  
If not pre-mounted

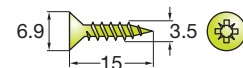

820-6308-050

10000 Pcs

Hinge angle restrictor  
→ see page 2.171



TouchControl Solutions  
→ see pages 2.193-2.204



Soft closing systems  
→ see pages 2.183-2.190



Door adjustment

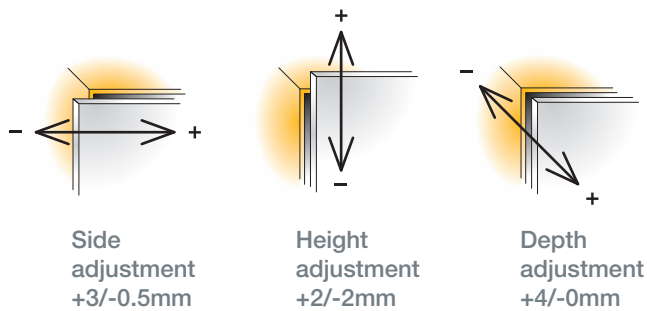

For further explanation → see pages 2.20-2.22

Mounting details

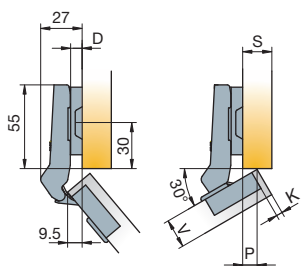

Mounting plate drilling distance

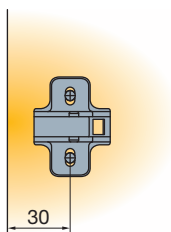

Mounting plate thickness table

For further explanation → see page 2.11

P	2.5	3.5	4.5	8.5	9.5	10.5	11.5	12.5	13.5
3	9			3	2	1	0		
K 4		9			3	2	1	0	
5			9			3	2	1	0 D

Drawings show application on D=3mm mounting plate

Door clearance

For further explanation → see page 2.12

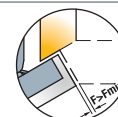

V	16	17	18	19	20	21	22
3	0.3	0.5	0.7	1.0	1.3	1.7	2.5
K 4	0.3	0.5	0.7	0.9	1.2	1.6	2.1
5	0.3	0.5	0.7	0.9	1.2	1.5	2.0 F <sub>MIN</sub>

Gap Z<sub>MIN</sub>=0

# B-type 110/45°

45° angled application for wood doors

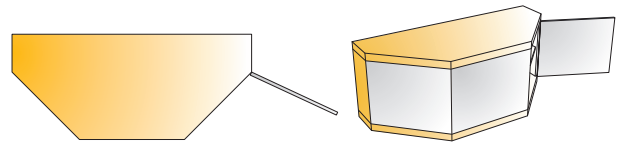
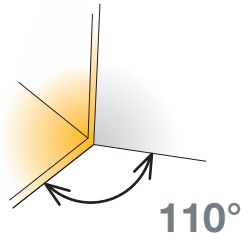

- Opening angle 110°
- Drilling diameter for hinge cup 35mm
- Drilling depth 11.5mm
- Hinge on plate mounting system slide-on



Technical details

Cup type	Interaxis 45mm	Interaxis 48mm
Item number	Item number	Item number
Screw-on	248-0L32-650	248-0L27-650
Machine insertion	248-0N38-050	248-0L71-050

Drilling patterns for hinge cups → see page 2.15

Cranking  
9mm

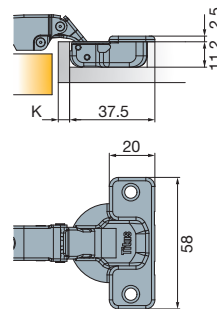
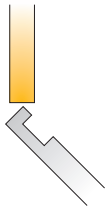

200 Pcs

Cup made of steel, arm made of zinc

Mounting plates  
→ see pages 2.163-2.166



Cover caps for hinge arm  
→ see page 2.173



Hinge cup screws  
If not pre-mounted

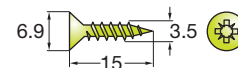

820-6308-050

10000 Pcs

Hinge angle restrictor  
→ see page 2.171



TouchControl Solutions  
→ see pages 2.193-2.204



Soft closing systems  
→ see pages 2.183-2.190



Door adjustment

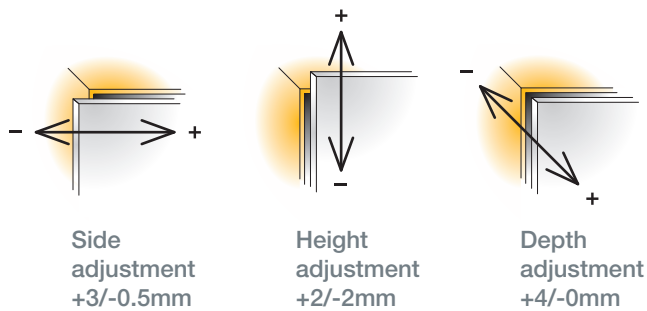

For further explanation → see pages 2.20-2.22

Mounting details

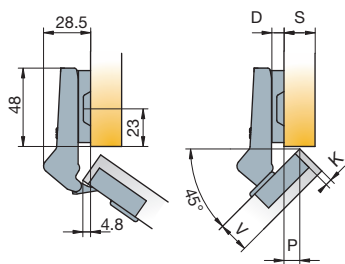

Drawings show application on D=3mm mounting plate

Mounting plate drilling distance

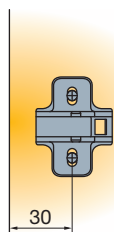

Mounting plate thickness table

For further explanation → see page 2.11

P	9	9.5	10	10.5	11	11.5	12	12.5	13.5
3	3		2		1		0		
K 4		3		2		1		0	
5				3		2		1	0 D

Door clearance

For further explanation → see page 2.12

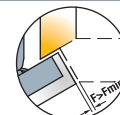

V	16	17	18	19	20	21	22
3	0.3	0.5	0.7	1.0	1.3	1.7	2.5
K 4	0.3	0.5	0.7	0.9	1.2	1.6	2.1
5	0.3	0.5	0.7	0.9	1.2	1.5	2.0 F <sub>MIN</sub>

Gap Z<sub>MIN</sub>=0

# B-type 110/45°

45° angled application for wood doors

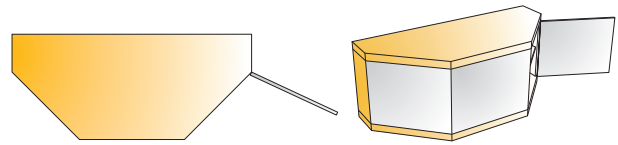
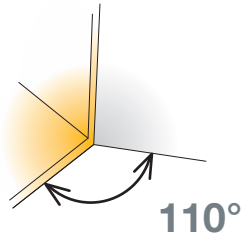

- Opening angle 110°
- Drilling diameter for hinge cup 35mm
- Drilling depth 11.5mm
- Hinge on plate mounting system slide-on



Technical details

Cup type	Interaxis 45mm	Interaxis 48mm
Item number	Item number	Item number
Screw-on	248-0L33-050	248-0L28-050
Machine insertion	248-0L46-050	248-0L70-050

Drilling patterns for hinge cups → see page 2.15

Cranking  
18mm

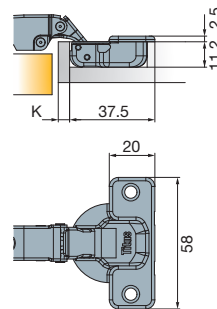
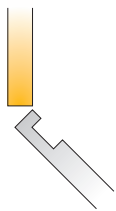

200 Pcs

Cup made of steel, arm made of zinc

Mounting plates  
→ see pages 2.163-2.166



Cover caps for hinge arm  
→ see page 2.173



Hinge cup screws  
If not pre-mounted

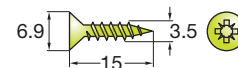

820-6308-050

10000 Pcs

Hinge angle restrictor  
→ see page 2.171



TouchControl Solutions  
→ see pages 2.193-2.204



Soft closing systems  
→ see pages 2.183-2.190



Door adjustment

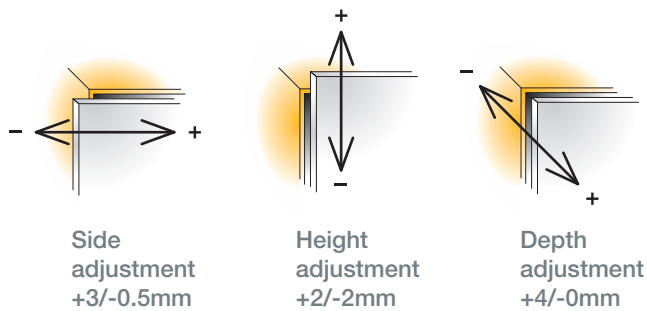

For further explanation → see pages 2.20-2.22

Mounting details

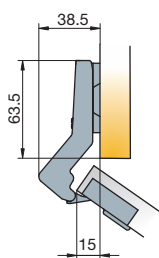

Drawing shows application on D=0mm mounting plate

Mounting plate drilling distance

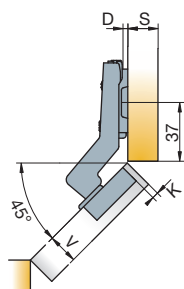

Drawings show application on D=3mm mounting plate

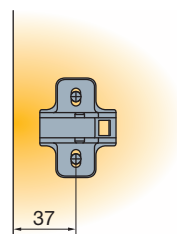

Mounting plate thickness table

For further explanation → see page 2.11

	3	0	
K	4	1	
	5	2	D

Door clearance

For further explanation → see page 2.12

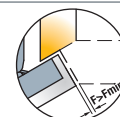

V	16	17	18	19	20	21	22		
3	0.3	0.5	0.7	1.0	1.3	1.7	2.5		
K	4	0.3	0.5	0.7	0.9	1.2	1.6	2.1	
	5	0.3	0.5	0.7	0.9	1.2	1.5	2.0	F <sub>MIN</sub>

Gap Z<sub>MIN</sub>=0

# B-type 110/90°

For wood door cabinets with blind panels

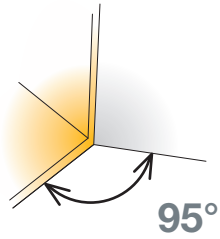
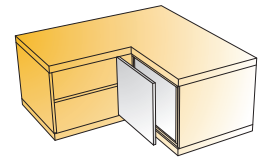

- Opening angle 95°
- Drilling diameter for hinge cup 35mm
- Drilling depth 11.5mm
- Hinge on plate mounting system slide-on



Technical details

Cup type	Interaxis 45mm	Interaxis 48mm
Item number		

Cranking

0mm

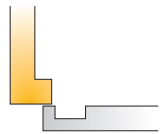

200 Pcs

Cup made of steel, arm made of zinc

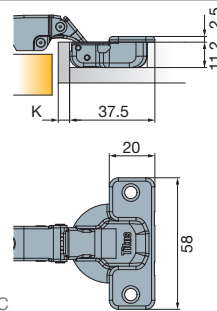

	248-0255-050	248-0V66-050
--	--------------	--------------

Drilling patterns for hinge cups → see page 2.15

**i** Opening angle 110°

Cranking

18mm



200 Pcs

Cup made of steel, arm made of zinc

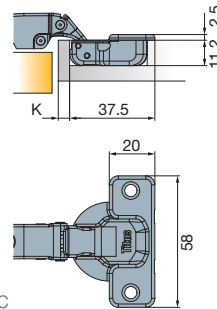

	248-0G58-050	248-0G53-050
--	--------------	--------------

	248-0G83-050	248-0L73-050
--	--------------	--------------

Drilling patterns for hinge cups → see page 2.15

**i** Opening angle 95°

Blind panel mounting plate



200 Pcs

Made of zinc

	244-0810-650	
	11	244-0813-650
	13	244-0C32-650
	15	244-0P28-650

This mounting plate can be only used with B-type 110/90° hinges. Information about mounting plate symbols → see page 2.164

Hinge cup screws  
If not pre-mounted

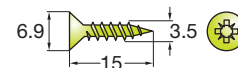

820-6308-050

10000 Pcs

Hinge angle restrictor  
→ see page 2.171



TouchControl Solutions  
→ see pages 2.193-2.204



Soft closing systems  
→ see pages 2.183-2.190



Door adjustment

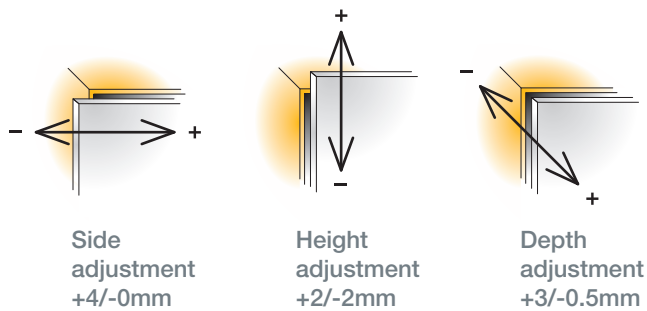

For further explanation → see pages 2.20-2.22

Mounting details

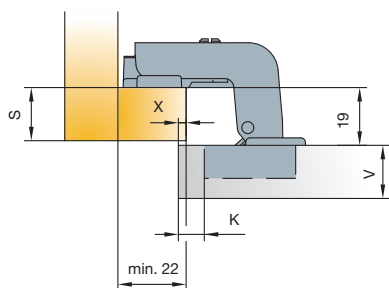

Mounting plate drilling distance

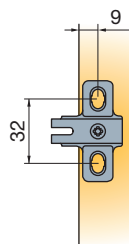
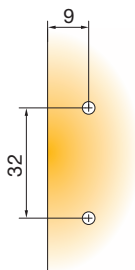
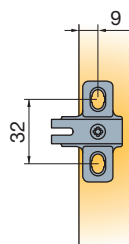
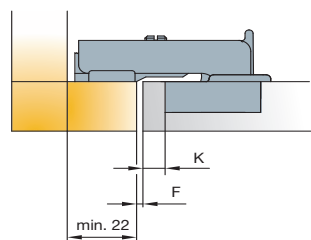
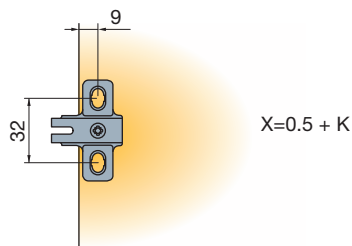

Door clearance

For further explanation → see page 2.12



V	16	17	18	19	20	21	22	
3	0.3	0.5	0.7	1.0	1.3	1.7	2.5	
K	4	0.3	0.5	0.7	0.9	1.2	1.6	2.1
5	0.3	0.5	0.7	0.9	1.2	1.5	2.0	F <sub>MIN</sub>

Gap Z<sub>MIN</sub>=0

# B-type 110 AL

For aluminium frame doors

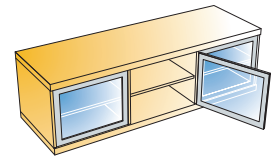
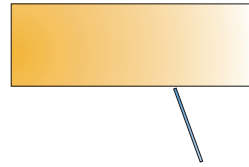
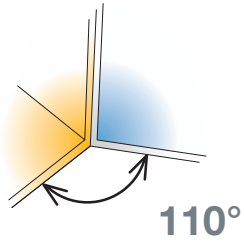

- Opening angle
- Drilling depth
- Hinge on plate mounting system

110°  
11.5mm  
slide-on



Interaxis <b>28mm</b>	
Cup type	Item number

Cranking  
**0mm**



200 Pcs

Cup made of zinc, arm made of steel

 Screw-on	<b>950-0T26-050</b>
* Fixing screws included	

Cranking  
**9mm**

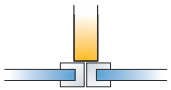

200 Pcs

Cup made of zinc, arm made of steel

 Screw-on	<b>950-0T49-050</b>
* Fixing screws included	

Cranking  
**15mm**

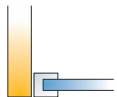

200 Pcs

Cup made of zinc, arm made of steel

 Screw-on	<b>950-0T51-050</b>
* Fixing screws included	

Mounting plates  
→ see pages 2.163-2.166



Cover caps for hinge arm  
→ see page 2.173



Hinge cup screws  
included

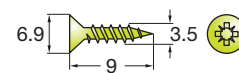

**820-6350-050**  
10000 Pcs

Hinge angle restrictor  
→ see page 2.171



TouchControl Solutions  
→ see pages 2.193-2.204



Door adjustment

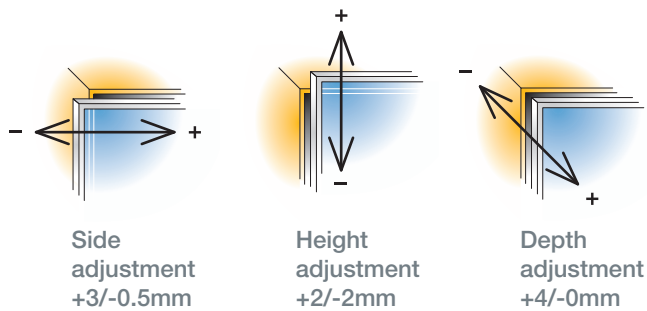

For further explanation → see pages 2.20-2.22

Mounting details

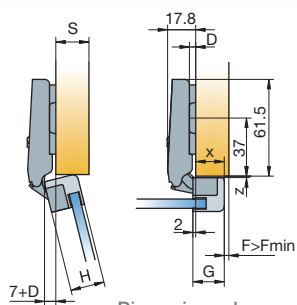

Dimensions shown on m.pl. D=0mm

Mounting plate drilling distance

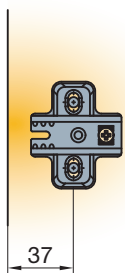

Mounting plate thickness table

For further explanation → see page 2.11

X	12	13	14	15	16	17	18
17	3	2	1	0			
18	4	3	2	1	0		
G	5	4	3	2	1	0	
20	6	5	4	3	2	1	0
							<b>D</b>

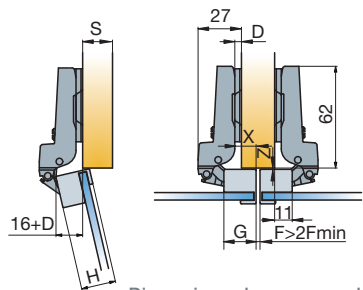

Dimensions shown on m.pl. D=0mm

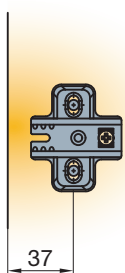

X	3	4	5	6	7	8	9
17	3	2	1	0			
18	4	3	2	1	0		
G	5	4	3	2	1	0	
20	6	5	4	3	2	1	0
							<b>D</b>

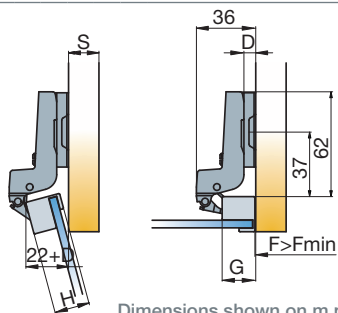

Dimensions shown on m.pl. D=3mm

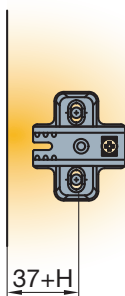

H	17	18	19	20	21	22
17	1	1	2	2	2	3
18	2	2	3	3	3	3
G	3	3	3	3		
20	2	2				
						<b>D</b>

Drilling pattern for aluminium frame hinges

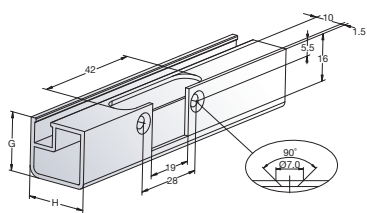

Mounting details

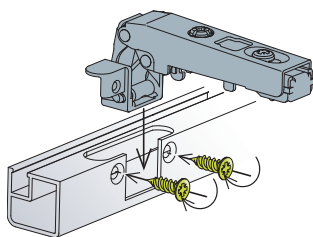

Screws included

Door clearance

For further explanation → see page 2.12

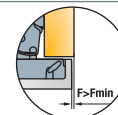

H	17	18	19	20	21	22
17	0.5	0.7	1.1	1.4	1.8	2.9
18	0.5	0.7	1.0	1.3	1.7	2.5
G	0.5	0.7	0.9	1.2	1.6	2.1
20	0.5	0.7	0.9	1.2	1.5	2.0
						<b>F<sub>MIN</sub></b>

Gap Z<sub>MIN</sub>=0.5

# B-type 110 AL

For aluminium frame doors  
Glissando AL soft closing ready

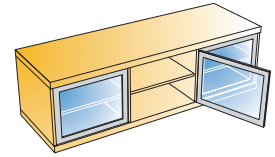
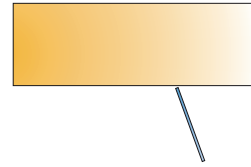
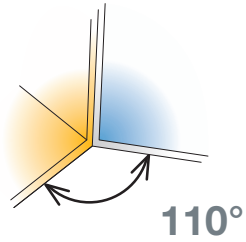

- Opening angle
- Drilling depth
- Hinge on plate mounting system

110°  
11.5mm  
slide-on



Interaxis  
28mm

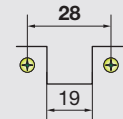

Cup type

Item number

Cranking  
0mm

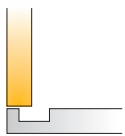

200 Pcs

Made of steel and zinc

Screw-on

950-0464-050

\* Fixing screws included

Cranking  
9mm

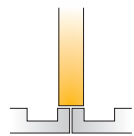

200 Pcs

Made of steel and zinc

Screw-on

950-0465-050

\* Fixing screws included

Cranking  
15mm

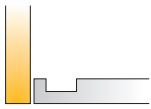

200 Pcs

Made of steel and zinc

Screw-on

950-0466-050

\* Fixing screws included

Mounting plates

→ see pages 2.163-2.166



Cover caps for hinge arm

→ see page 2.173



Hinge cup screws

included

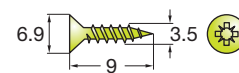

820-6350-050

10000 Pcs

Hinge angle restrictor

→ see page 2.171



TouchControl Solutions

→ see pages 2.193-2.204



Soft closing systems

→ see page 2.187



· Hinge for aluminium frame door which can be used with Glissando AL for soft closing solution

Door adjustment

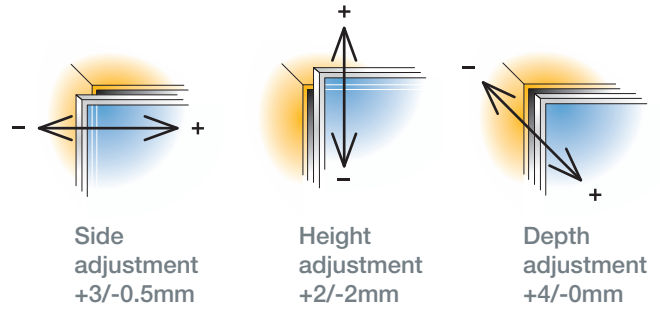

For further explanation → see pages 2.20-2.22

Mounting details

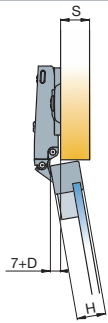

Mounting plate drilling distance

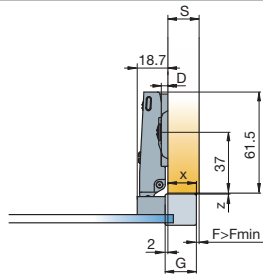

Dimensions shown on m.pl. D=0mm

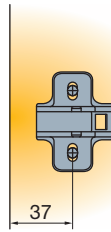

Mounting plate thickness table

For further explanation → see page 2.11

X	12	13	14	15	16	17	18		
17	3	2	1	0					
18	4	3	2	1	0				
G	19	5	4	3	2	1	0		
	20	6	5	4	3	2	1	0	D

$D=13+K-X$

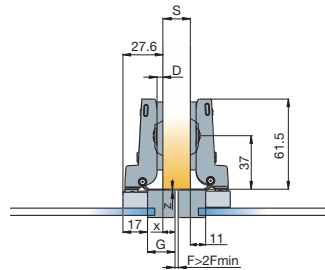
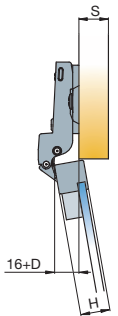

Dimensions shown on m.pl. D=0mm

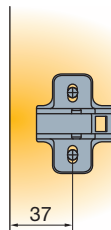

X	3	4	5	6	7	8	9		
17	3	2	1	0					
18	4	3	2	1	0				
G	19	5	4	3	2	1	0		
	20	6	5	4	3	2	1	0	D

$D=4+K-X$

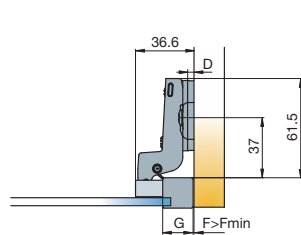
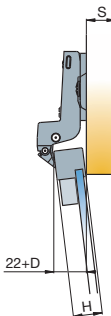

Dimensions shown on m.pl. D=3mm

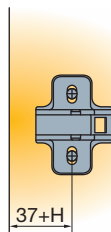

X	17	18	19	20	21	22	
17	1	1	2	2	3	3	
18	2	2	3	3	3	3	
G	19	3	3	3			
	20	3	3				D

$D=-2+K+F$

Drilling pattern for aluminium frame hinges

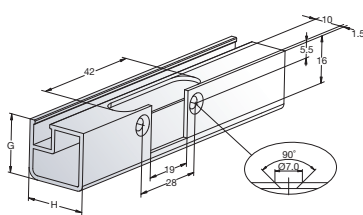

Mounting details

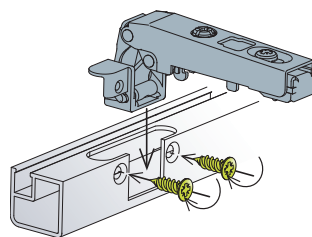

Screws included

Door clearance

For further explanation → see page 2.12

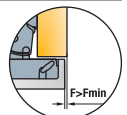

H	17	18	19	20	21	22		
17	0.5	0.7	1.1	1.4	1.8	2.9		
18	0.5	0.7	1.0	1.3	1.7	2.5		
G	19	0.5	0.7	0.9	1.2	1.6	2.1	
	20	0.5	0.7	0.9	1.2	1.5	2.0	F <sub>MIN</sub>

Gap Z<sub>MIN</sub>=0.5

# B-type 170

For wood doors

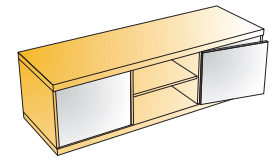
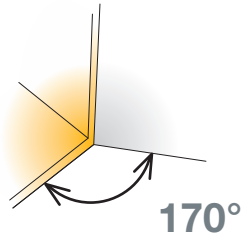

- Opening angle
- Drilling diameter for hinge cup
- Drilling depth
- Hinge on plate mounting system

170°  
35mm  
12mm  
slide-on

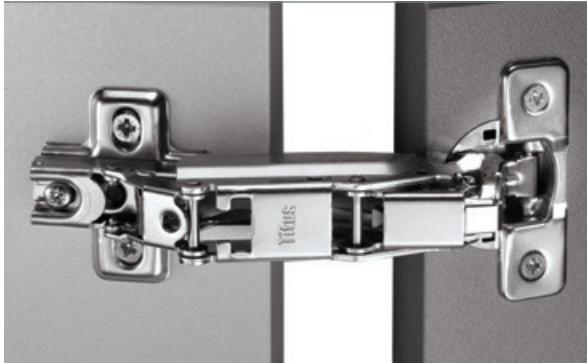

Technical details

Cup type	Interaxis 45mm	Interaxis 48mm
	Item number	248-0R10-050
Item number	248-0L51-050	248-0R12-050

Interaxis  
45mm

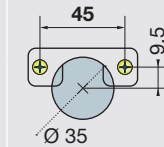

Interaxis  
48mm

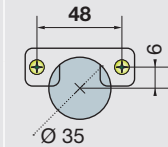

Cranking  
0mm

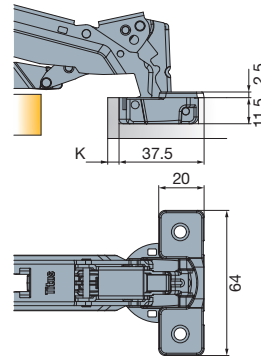

Screw-on

248-0R10-050

248-0P43-050



Machine insertion

248-0L51-050

248-0R12-050

Drilling patterns for hinge cups → see page 2.15

50 Pcs

Made of steel and zinc

Mounting plates

→ see pages 2.163-2.166



Hinge cup screws

If not pre-mounted

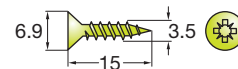

820-6308-050

10000 Pcs

Hinge angle restrictor

→ see page 2.171



TouchControl Solutions

→ see pages 2.193-2.204



Soft closing systems

→ see page 2.185



Zero protrusion  
with D=0 mounting plate

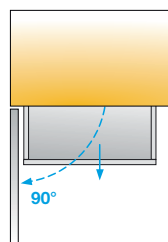

Door adjustment

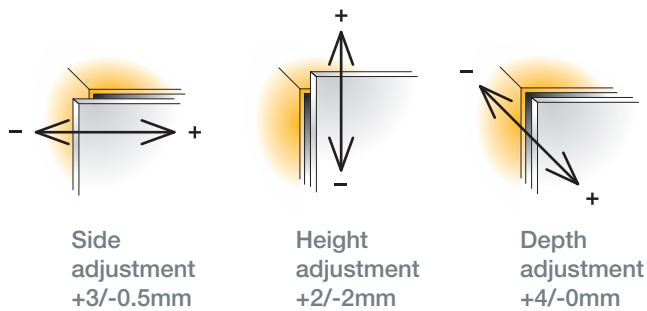

Side  
adjustment  
+3/-0.5mm

Height  
adjustment  
+2/-2mm

Depth  
adjustment  
+4/-0mm

For further explanation → see pages 2.20-2.22

Mounting  
details

Mounting plate  
drilling distance

Mounting plate thickness table  
For further explanation → see page 2.11

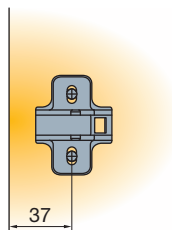
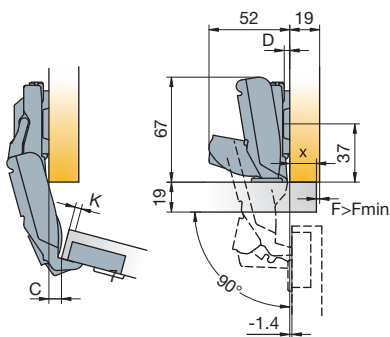

Drawings show application on  
D=0mm mounting plate  
No door protrusion in 90° position

X	10	11	12	13	14	15	16	17	18	19	20
3	6	5	4	3	2	1	0				
4		6	5	4	3	2	1	0			
K	5		6	5	4	3	2	1	0		
6				6	5	4	3	2	1	0	
7					6	5	4	3	2	1	0

$D=13+K-X$

C value with D=0 mounting plates

K	3	4	5	6	7
	-9.0	-8.1	-7.1	-6.1	-5.2

**C**

Door clearance

For further explanation → see page 2.12

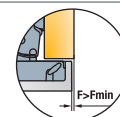

V	16	17	18	19	20	21	22	23	24
3	0.0	0.0	0.0	0.0	0.0	0.0	0.0	0.0	0.0
4	0.0	0.0	0.0	0.0	0.0	0.0	0.0	0.0	0.0
K	5	0.0	0.0	0.0	0.0	0.0	0.0	0.0	0.0
6	0.0	0.0	0.0	0.0	0.0	0.0	0.0	0.0	2.6
7	0.0	0.0	0.0	0.0	0.0	0.0	0.0	0.0	5.1 F <sub>MIN</sub>

Gap Z<sub>MIN</sub>=0

# B-type 170

For wood doors

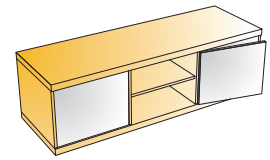
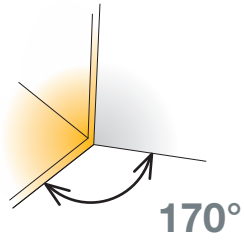

- Opening angle
- Drilling diameter for hinge cup
- Drilling depth
- Hinge on plate mounting system

170°  
35mm  
12mm  
slide-on

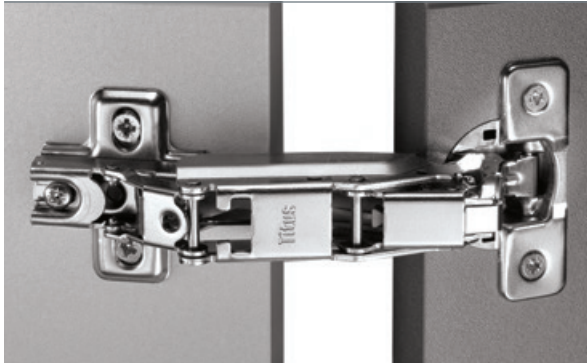

Technical details

Cup type	Interaxis 45mm	Interaxis 48mm
Item number	248-0160-050	248-0161-050

Cranking  
9mm

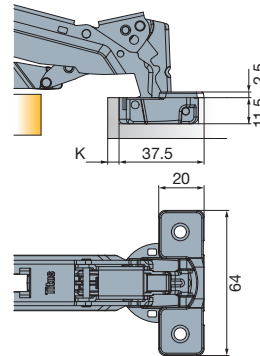
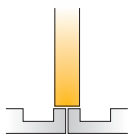

Screw-on  
248-0160-050  
248-0161-050  
Drilling patterns for hinge cups → see page 2.15

50 Pcs

Made of steel and zinc

Mounting plates  
→ see pages 2.163-2.166



Hinge cup screws  
If not pre-mounted

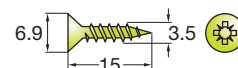

820-6308-050

10000 Pcs

Hinge angle restrictor  
→ see page 2.171



TouchControl Solutions  
→ see pages 2.193-2.204



Soft closing systems  
→ see page 2.185



Door adjustment

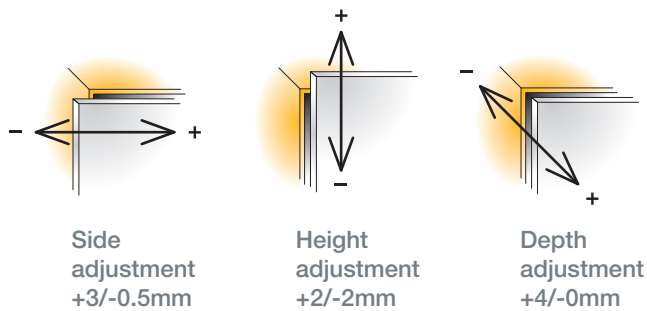

For further explanation → see pages 2.20-2.22

Mounting details

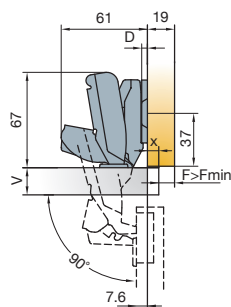
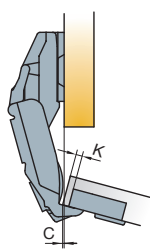

Mounting plate drilling distance

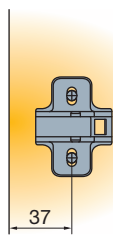

Mounting plate thickness table

For further explanation → see page 2.11

X	1	2	3	4	5	6	7	8	9	10	11
3	6	5	4	3	2	1	0				
4		6	5	4	3	2	1	0			
K 5			6	5	4	3	2	1	0		
6				6	5	4	3	2	1	0	
7					6	5	4	3	2	1	0

$D=4+K-X$

C value with D=0 mounting plates

K	3	4	5	6	7
	0	0.9	1.9	2.9	3.8

Drawings show application on D=0mm mounting plate

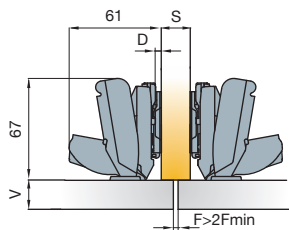

Drawing shows application on D=0mm mounting plate

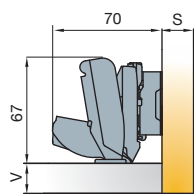

Drawing shows application on D=9mm mounting plate

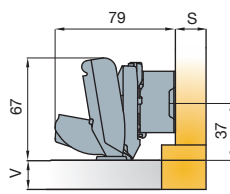

Drawing shows application on D=18mm mounting plate

Door clearance

For further explanation → see page 2.12

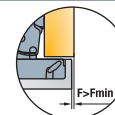

V	16	17	18	19	20	21	22	23	24
3	0.0	0.0	0.0	0.0	0.0	0.0	0.0	0.0	0.0
4	0.0	0.0	0.0	0.0	0.0	0.0	0.0	0.0	0.0
K 5	0.0	0.0	0.0	0.0	0.0	0.0	0.0	0.0	0.0
6	0.0	0.0	0.0	0.0	0.0	0.0	0.0	0.0	2.6
7	0.0	0.0	0.0	0.0	0.0	0.0	0.0	0.0	5.1

Gap Z<sub>MIN</sub>=0

# B-type for Pie-cut Corner Cabinet

For wood doors

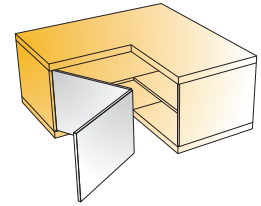

- Drilling diameter for hinge cup 35mm
- Drilling depth 11.5mm
- Hinge on plate mounting system slide-on



Technical details

Cup type	Interaxis 45mm	Interaxis 48mm
Item number	Item number	Item number
Screw-on Machine insertion	248-0T81-050	248-0T80-050
	248-0U13-050	248-0U14-050

Drilling patterns for hinge cups → see page 2.15

Corner cabinet

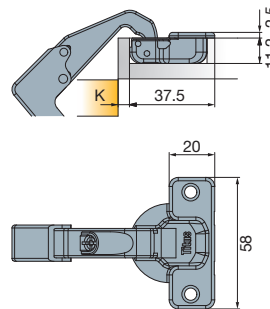
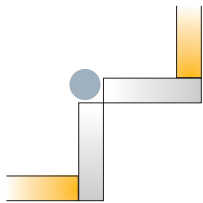

100 Pcs

Cup made of steel, arm made of zinc

**Mounting plates**

→ see pages 2.163-2.166



**Cover caps for hinge arm**

→ see page 2.173



**Hinge cup screws**

If not pre-mounted

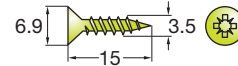

820-6308-050

10000 Pcs

**TouchControl Solutions**

→ see pages 2.193-2.204



· Use in pair with 170° hinge

Door adjustment

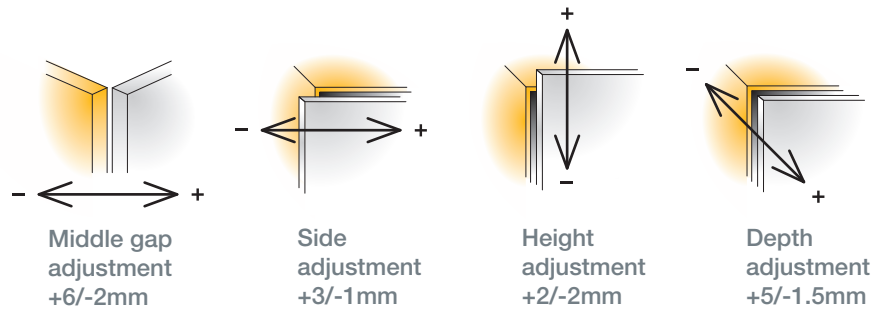

For further explanation → see pages 2.20-2.22

Mounting details

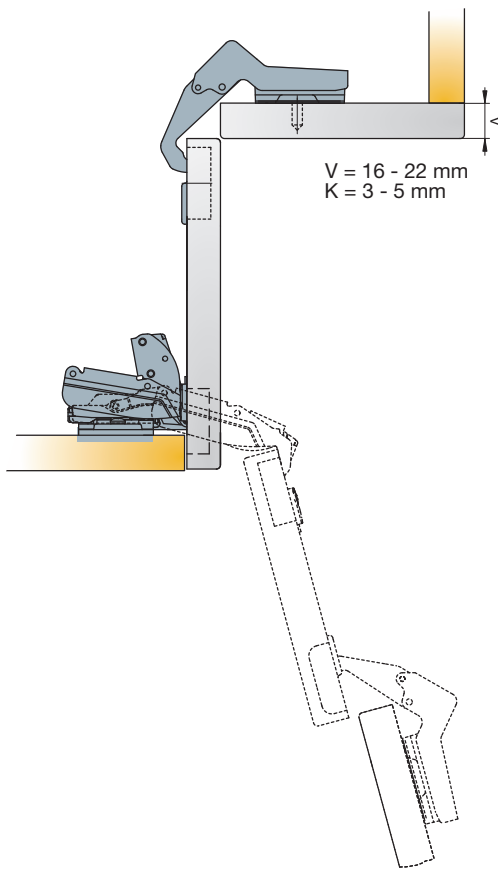

Mounting plate drilling distance

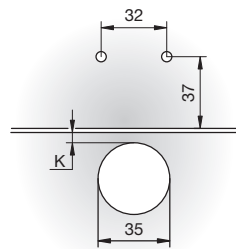

Adjustments

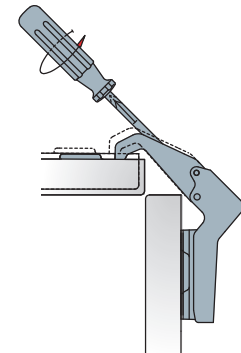

The diagonal adjustment is made by rotating the appropriate screw as shown on the drawing.

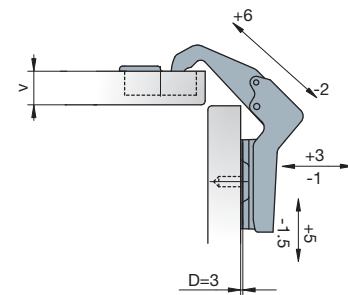

Drawings show application on D=3 mm mounting plate.

# B-type Flap door hinge

For wood doors

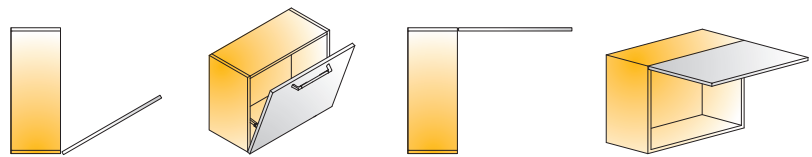

- Opening angle
- Drilling diameter for hinge cup
- Drilling depth
- Hinge on plate mounting system

90°  
35mm  
11.5mm  
slide-on



Interaxis  
**24mm**

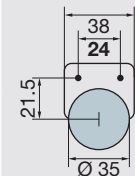

Cup type

Item number

Cranking  
**0mm**

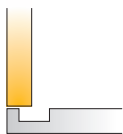

left



Screw-on

**926-0A26-050**

right



Screw-on

**926-0A27-050**

\* For application it is mandatory to order left and right hinge

200 Pcs

Cup made of steel

Mounting plates

→ see pages 2.163-2.166



Cover caps for hinge arm

→ see page 2.173



Hinge cup screws

If not pre-mounted

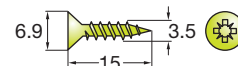

**820-6308-050**

10000 Pcs

TouchControl Solutions

→ see pages 2.193-2.204





Use with flap stay mechanisms

Door adjustment

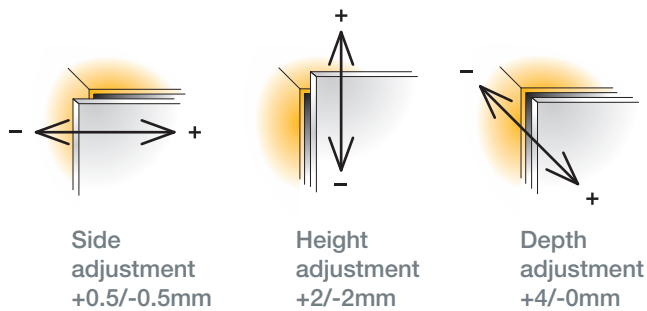

For further explanation → see pages 2.20-2.22

Mounting details

Mounting plate thickness table

For further explanation → see page 2.11

D	0	1	2	3
B	20	21	22	23

$$X = 22.5 + K - A$$

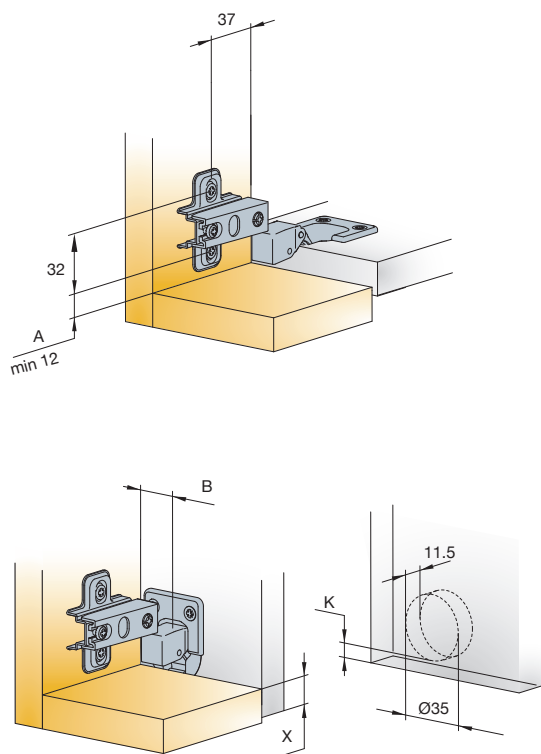

B = distance between two holes center for fixing screws on the hinge cup and side panel

Door clearance

For further explanation → see page 2.12

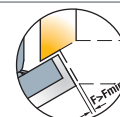

V	16	17	18	19	20	21	22
3	0.3	0.5	0.7	1.0	1.3	1.7	2.5
K	0.3	0.5	0.7	0.9	1.2	1.6	2.1
5	0.3	0.5	0.7	0.9	1.2	1.5	2.0

Gap Z<sub>MIN</sub>=0

# B-type Mounting Plates

## B-type slide-on mounting

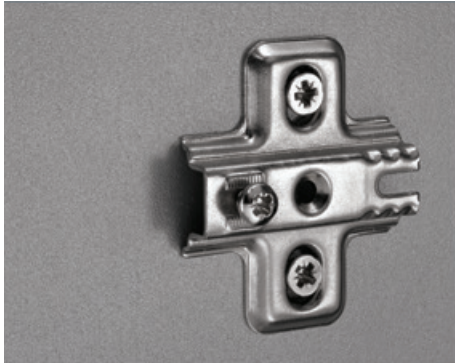
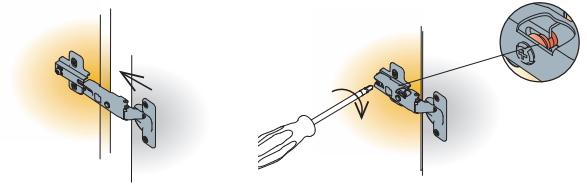

Cruciform mounting plate

Drilling pattern

Dimensions

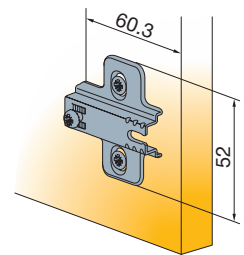
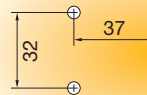

 200 Pcs    Made of steel

Zinc diecast cruciform mounting plate

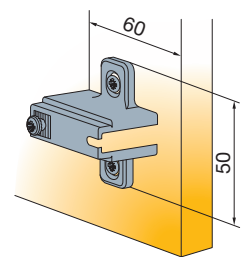
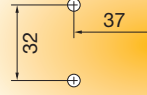

 200 Pcs    Made of zinc

Fixing screws for mounting plates  
*If not pre-mounted*

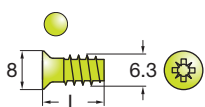

Euro screws  
821-6304-050 L=11  
821-6323-050 L=13  
821-6332-050 L=15

 10000 Pcs

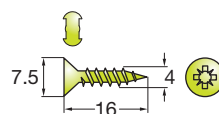

Chipboard screws  
820-6328-050

 10000 Pcs



Mounting plate thickness

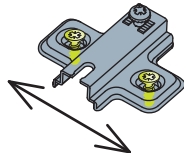

Height adjustment +/- 2mm

Mounting plate type								
Mounting plate thickness (D)								
Item number								
0mm	244-0866-050	*244-0L29-050	244-0965-050	244-0929-050	*244-0L26-050	*244-0L50-050	244-0H64-050	244-0P24-050
1mm	244-0T40-050		244-0K95-050		*244-0S65-050		244-0S67-050	
2mm	244-0T28-050		244-0K96-050		*244-0S66-050	*244-0V64-050	244-0S68-050	
3mm	244-0867-050	*244-0L39-050	244-0G19-050	244-0930-050	*244-0L98-050	*244-0L40-050	244-0H65-050	244-0P25-050
* Available upon special request → see page 0.3								
4mm	244-0L37-650		244-0K97-650				244-0M28-650	
5mm	244-0L38-650		244-0K98-650	244-0T14-650			244-0M29-650	
6mm	244-0232-650		244-0914-650			*244-0B12-650		
9mm	244-0062-650		244-0067-650	244-0P41-650				
18mm	244-0063-650		244-0068-650	244-0175-650				
* Available upon special request → see page 0.3								

Legend of mounting plate type symbols

Screw-on ready for euro screws ← screws	Screw-on ready for chipboard ← screws	Pre-mounted 13mm euro screws	Pre-mounted 15mm euro screws	Pre-mounted chipboard screws	Machine insertion ready	Pre-mounted 7.5mm expanding dowels	Pre-mounted 10.5mm expanding dowels

# B-type Mounting Plates

B-type slide-on mounting

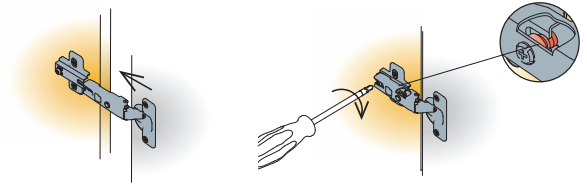

Cruciform mounting plate

· Back-to back application

Drilling pattern

Dimensions

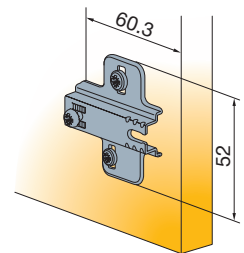
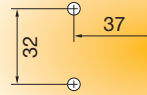

200 Pcs

Made of steel

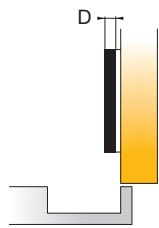

Mounting plate thickness

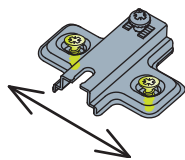

Height adjustment +/- 2mm

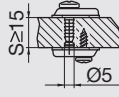
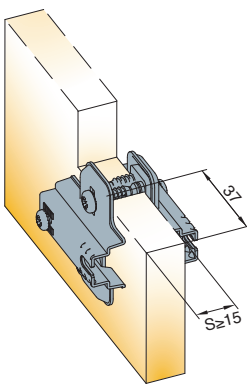
	Mounting plate type	 10.5		
	Mounting plate thickness (D)	 Item number		
	3mm	244-0V50-050		
 <p>Minimum panel thickness is 15mm</p>				

Legend of mounting plate type symbols



Pre-mounted 10.5mm expanding dowels

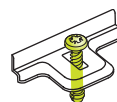

# Wide Angle Hinge 270

For wood doors

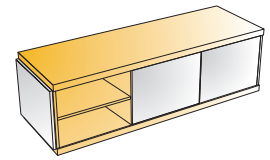
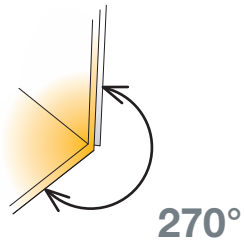

- Opening angle
- Drilling diameter for hinge cup
- Drilling depth
- Hinge on plate mounting system

270°  
35mm  
12.5mm  
key-hole



Technical details

Cup type	Item number
With spring	

Wide angle hinge 270

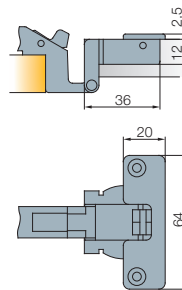
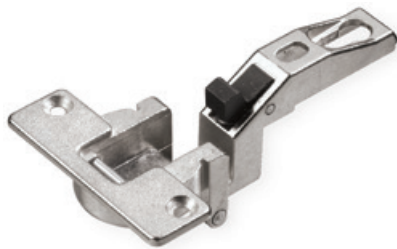

Screw-on	241-0043-650
Machine insertion	241-0050-650

200 Pcs

Made of zinc

Cruciform mounting plate



D=0mm

Screw-on	244-0907-650
----------	--------------

D=2mm

13 Pre-mounted	244-0848-650
----------------	--------------

D=6mm

Screw-on	244-0D99-650
----------	--------------

13 Pre-mounted	244-0E02-650
----------------	--------------

Screw-on	244-0D47-650
----------	--------------

13 Pre-mounted	244-0D46-650
----------------	--------------

This mounting plate can be only used with Wide angle hinge 270. Information about mounting plate symbols → see page 2.16

200 Pcs

Made of zinc

Hinge cup screws  
If not pre-mounted

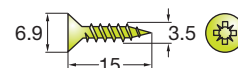

820-6308-050

10000 Pcs

Door adjustment

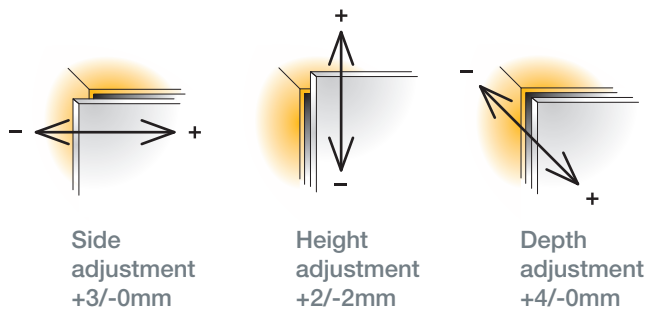

For further explanation → see pages 2.20-2.22

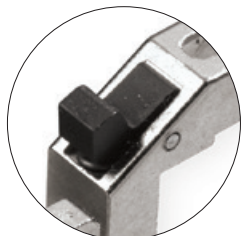

With spring catch

Mounting details

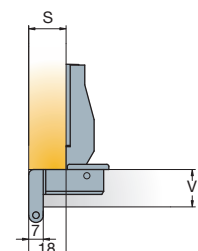

Drawing shows application on D=0 mounting plate and S=18 side panel.

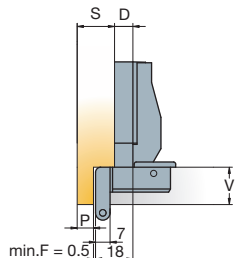

Drawing shows application on D=6mm mounting plate

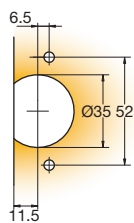

Mounting plate drilling distance

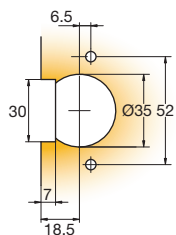

Mounting plate drilling distance

Mounting plate thickness table

For further explanation → see page 2.11

S	16	17	18	19	20	21	22	23	24
0	2		0						
1		2		0					
2			2		0				
3				2		0			
4	6				2		0		
5		6				2		0	
P 6			6				2		0
7				6				2	
8					6				2
9						6			
10							6		
11								6	
12									6

Door thickness



For correct opening, door thickness has to be (V<sub>MAX</sub>) 21mm

# Refrigerator Cabinet Hinge

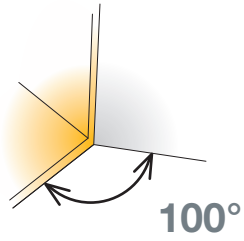

- Opening angle 100°
- Drilling diameter for hinge cup 35mm
- Drilling depth 11mm
- Hinge on plate mounting system key-hole



Technical details

Cup type	Interaxis 45mm	Interaxis 48mm
Item number		

Cranking  
0mm

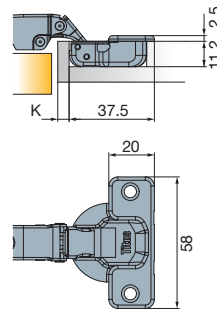
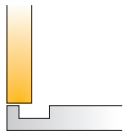

Screw-on	248-0R09-050	248-0K10-050
Machine insertion		248-0M41-050

Drilling patterns for hinge cups → see page 2.15

200 Pcs Cup made of steel, arm made of zinc

Cruciform mounting plate



Screw-on	244-0655-050	
13 Pre-mounted	244-0846-050	

This mounting plate can be only used with Refrigerator Cabinet Hinge.  
Information about mounting plate symbols → see page 2.16

500 Pcs Made of steel

Hinge cup screws  
If not pre-mounted

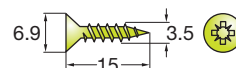

820-6308-050

10000 Pcs

Door adjustment

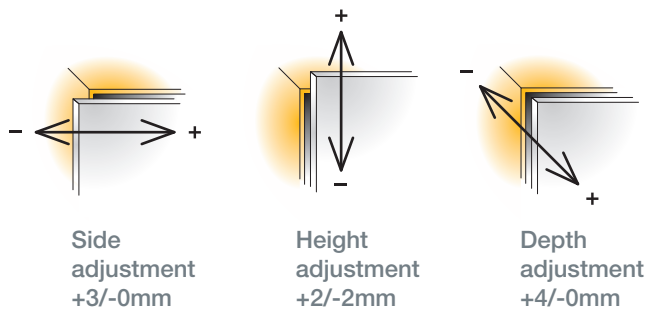

For further explanation → see pages 2.20-2.22

Mounting details

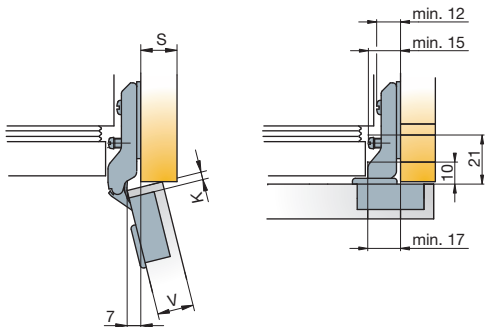

Drawings show application on mounting plate

Mounting plate drilling distance

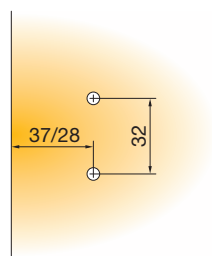
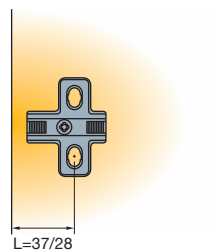

Door clearance

For further explanation → see page 2.12

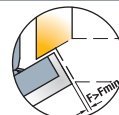

V	16	17	18	19	20	21	22	
3	0.3	0.5	0.7	1.0	1.3	1.7	2.5	
K	4	0.3	0.5	0.7	0.9	1.2	1.6	2.1
5	0.3	0.5	0.7	0.9	1.2	1.5	2.0	F <sub>MIN</sub>

Gap Z<sub>MIN</sub>=0

# Hinge Angle Restrictors

For all Titus Hinges with 110° and 170° opening angle

For 110 hinges

For 170 hinges

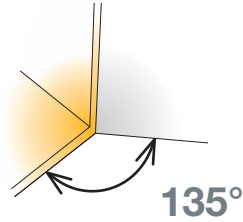
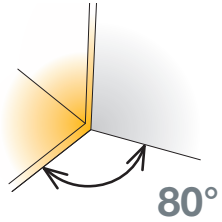

Technical details

Item number

Light grey

80° Hinge Angle Restrictor T-type

For all T-type 110°

728-4669 →

380

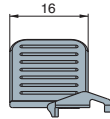

200 Pcs

Made of plastic

80° Hinge Angle Restrictor S-type, B-type

For all S-type 110° and B-type 110°

248-4668 →

380

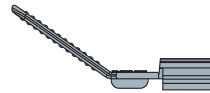
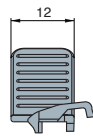

200 Pcs

Made of plastic

135° Hinge Angle Restrictor

For all 170° hinges

248-4672 →

380

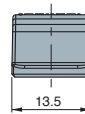

200 Pcs

Made of plastic

- Hinge angle restrictor limits opening angle
- Prevents door damage
- Easy and quick mounting and dismounting

Mounting details

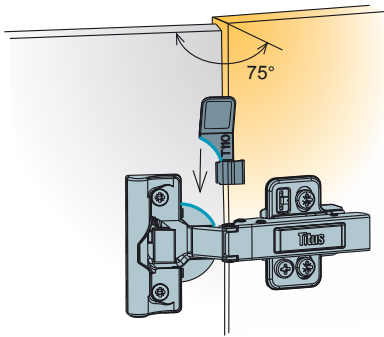

Open the door to approximately 75° and position angle restrictor to follow the hinge cup form

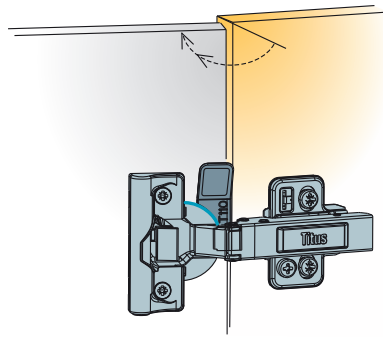

Push to fully open. Audible click indicates angle restrictor is in the right position

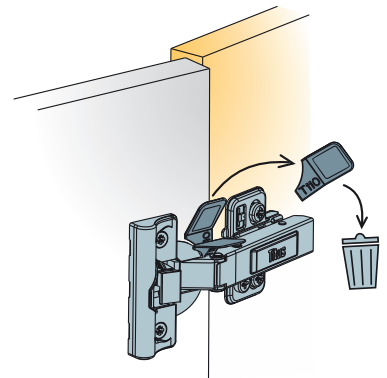

Close the door to remove the restrictor holder (cracks by itself while closing the door)

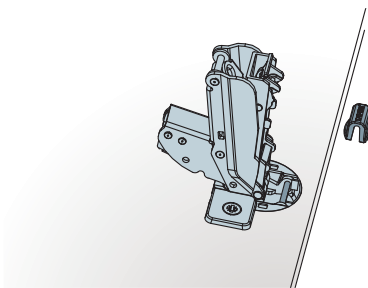

Hinge has to be in closed position

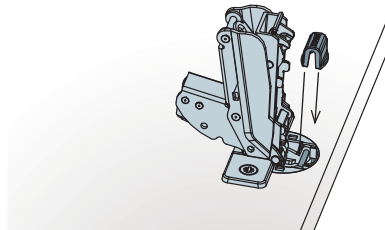

Insert angle restrictor into the hinge cup

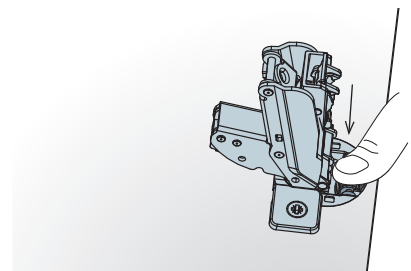







When angle restrictor is in the right position push it down

Recommended to insert angle restrictor while doors are not mounted on the cabinet

# Cover Caps

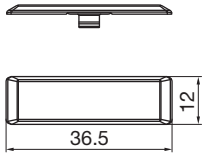
## For 110 hinges

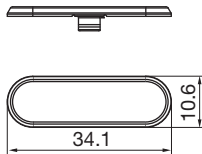
For hinge arms

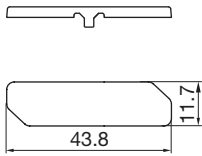
	Technical details	Logo	Item number	Nickel plated
<p><b>T-type</b></p>  <p>5000 Pcs    Made of steel</p>		Titus	728-1286 →	054
<p><b>T-type</b></p>  <p>5000 Pcs    Made of steel</p>		Titus	728-1287 →	054
<p><b>S-type B-type</b></p>  <p>4000 Pcs    Made of steel</p>		Titus	248-1646 →	050
Not for 5mm, 9mm, 17mm hinge cranking		without	728-1283 →	054
For all T-type range		without	728-1284 →	054
For all T-type range		without	248-1712 →	050



# Glissando Soft Closing Systems for Hinges

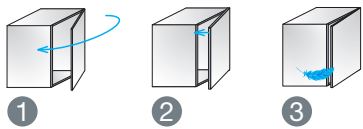

## ConfidentClose

- 1 Fast closing
- 2 Late start of deceleration action
- 3 Quiet landing with 'SoftTouch'

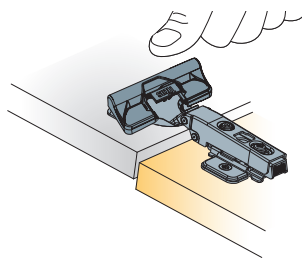

## Tool-less mounting

- Reduced assembly time
- Flexible usage also as a retrofit option

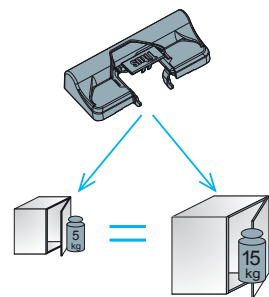

## Consistent Performance

- Only one Glissando for two to three hinges
- Allows for consistent performance on a wide range of door dimensions and weights

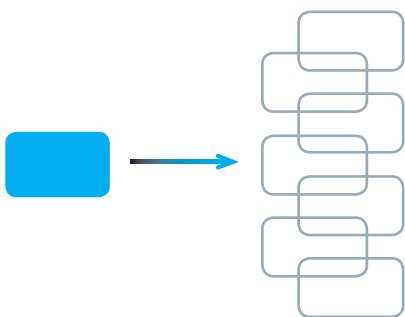

### One-for-all

- One item fits multiple applications
- Same item can be used on all crankings and angled hinges



### Titus Damper Inside

- Titus proprietary multi-purpose damping technology
- Efficient modular design
- Reliable and consistent damping

# Glissando Add-on

## Soft Closing Range

### How to Choose the Right Glissando?

Glissando TT  
 Glissando TL3  
 Glissando TL 170  
 Glissando CR  
 Glissando AL

Titus Glissando soft closing system is available for the whole range of hinge applications. The user can choose between add-on or stand-alone solutions.

Concealed hinges	Add-on hinge soft closing solutions			Stand-alone door soft closing solution	
	Glissando TT	Glissando TL3	Glissando TL 170	Glissando CR	Glissando AL
T-type 95	X			X	X
T-type 110	X			X	X
T-type 110/15°	X				
T-type 110/30°	X				
T-type 110/45°	X				
T-type 110/90°	X				
T-type 120	X			X	X
T-type 170			X	X	X
S-type 110		X		X	X
S-type 110/15°		X			
S-type 110/24°		X			
S-type 110/30°		X			
S-type 110/45°		X			
S-type 110/90°		X			
S-type 170			X	X	X
S-type 110 AL					X
B-type 110		X		X	X
B-type 110/30°		X			
B-type 110/45°		X			
B-type 110/90°		X			
B-type 170			X	X	X
B-type 110 AL					X



Titus Glissando soft closing devices can't be used with unsprung and reverse spring hinges.

## Glissando TT 'One-for-all'

### T-type

- One item fits multiple applications
- Same item can be used on all crankings and angled hinges
- Designed to fit the concealed hinge cup
- Tool-less mounting
- Suitable for different types of cabinets for kitchens, living rooms, bathrooms and other furniture

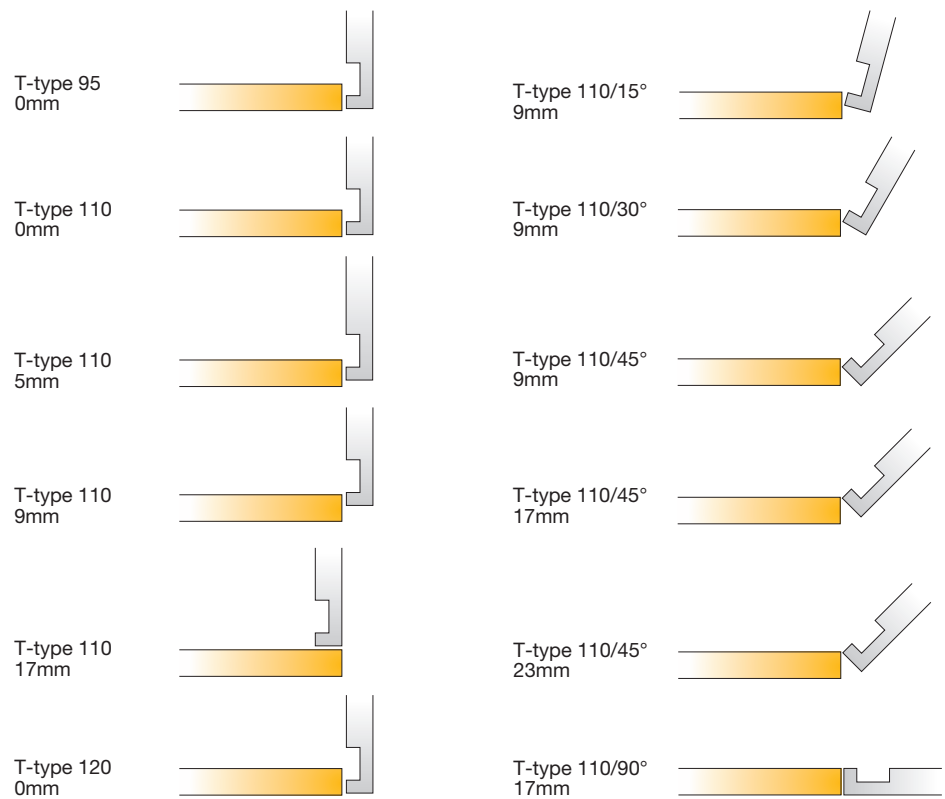
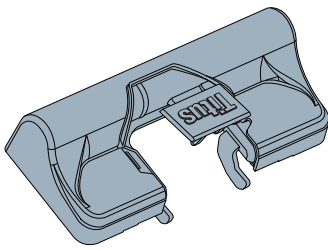

# Glissando

## Application

### Glissando TL3 'One-for-all'

#### S-type B-type

- One item fits multiple applications
- Same item can be used on all crankings and angled hinges
- Adjustable damping enables perfect functioning on every door
- Designed to fit the concealed hinge cup
- Tool-less mounting
- Suitable for different types of cabinets for kitchens, living rooms, bathrooms and other furniture

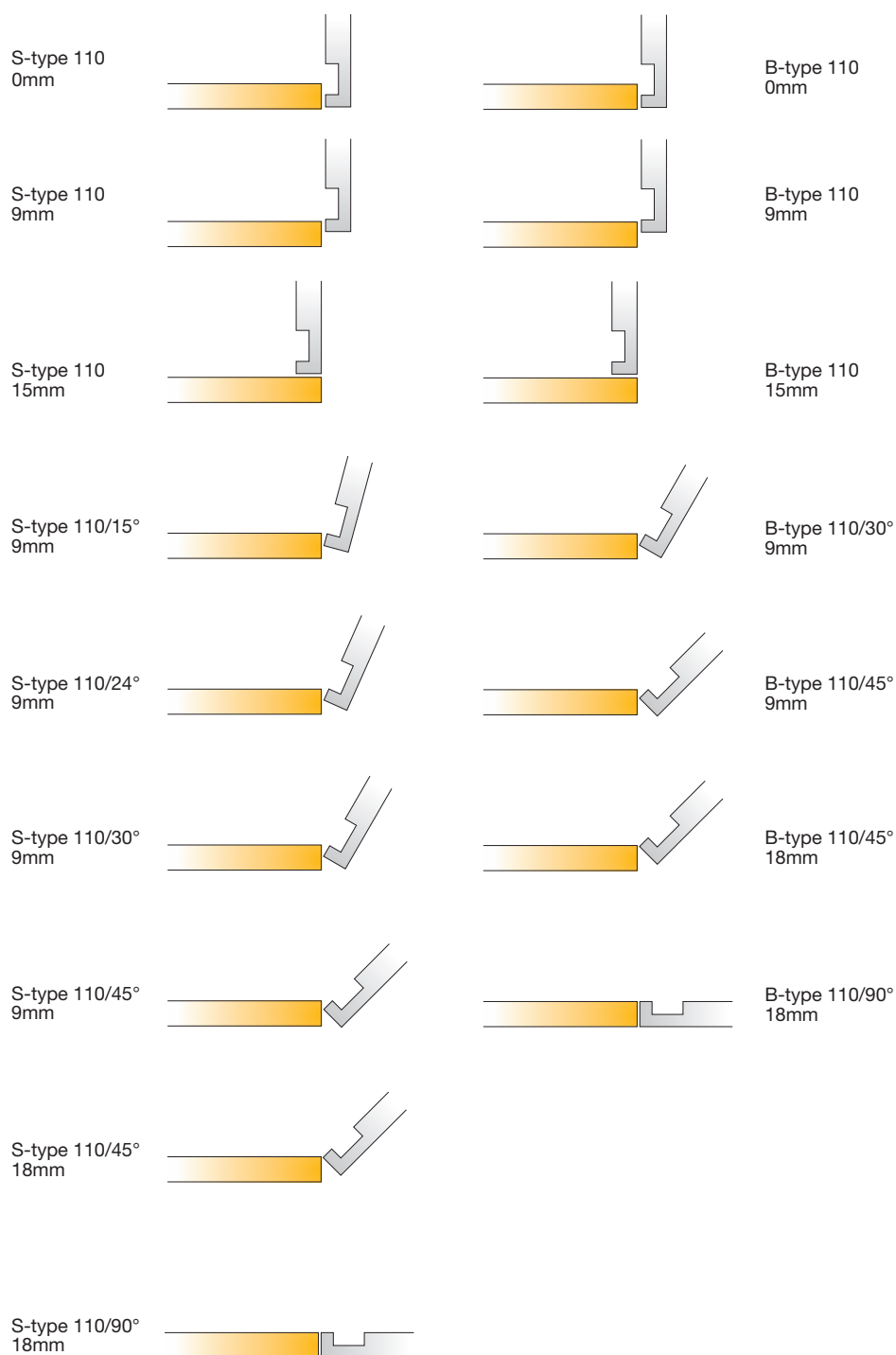
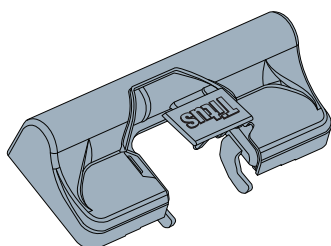

# Glissando

## Number per Door and Positioning

### How Many Glissandos per Door?

#### Add-on hinge soft closing solution

Glissando TT  
 Glissando TL3  
 Glissando TL 170

Number of Glissando per door depends on door dimensions, door weight, hinge arrangement. Trial mounting is recommended.

Glissando TT

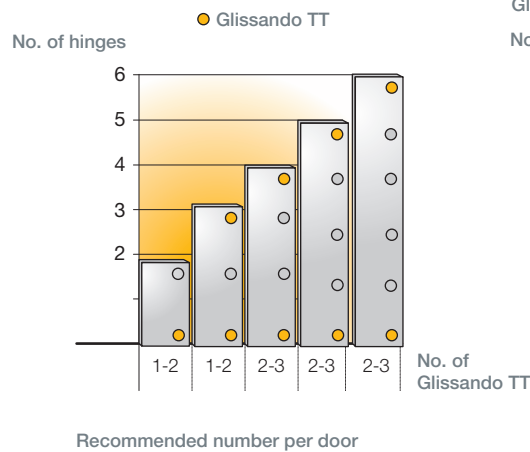

Glissando TL3  
 Glissando TL170

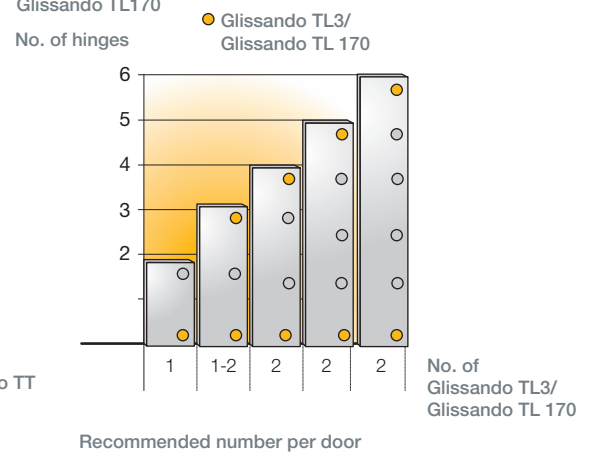

#### Stand-alone soft closing solution

Glissando CR  
 Glissando AL

Mount Glissando CR/AL on the hinged side of the cabinet on the top or bottom.

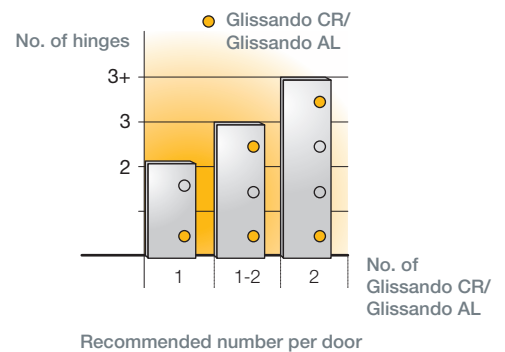

# Glissando Mounting

## How to Mount Glissando?

### Tool-less mounting

Glissando TL3  
Glissando TT  
Glissando TL 170

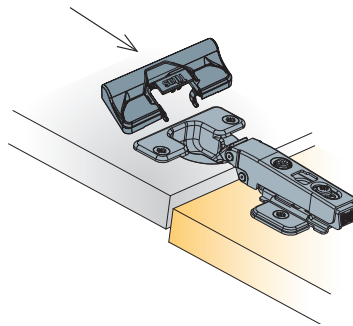

Simple tool-less assembly: Insert Glissando into the holes on the hinge and press down with hand.

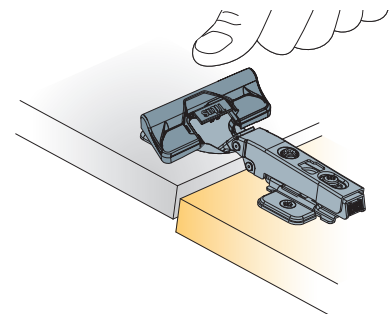

The tool-less 'snap on' version for reduced assembly time and flexibility of application. Glissando TL can be mounted at any time after furniture assembly so can be offered as a retro fit option by the installer.

### Screw-on into the cabinet corner

Glissando CR

Glissando CR is mounted into the cabinet corner by using chipboard screws 20mm long.

Glissando dampers' discreet design enhances the look of the door and occupies minimal space in the cabinet interior.

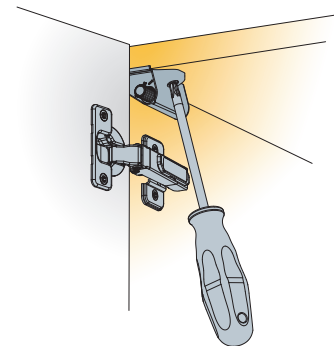

### Screw-on onto the mounting plate

Glissando AL

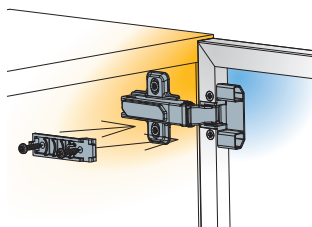

Position the mounting plate below the hinge arm and fix with two screws. Use hinge mounting plate as a reference.

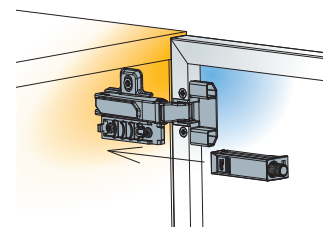

Slide Glissando AL onto the mounting plate

# Glissando

## Damping Adjustment

### How to Adjust Damping?

#### Add-on hinge soft closing solution

Glissando TL 170

Glissando features quarter turn adjustment to provide optimal closing speed for any door dimensions and weight.

The damping function can be adjusted to fit different door weights which enables

- perfect door functioning
- use of the same type of Glissando for various doors

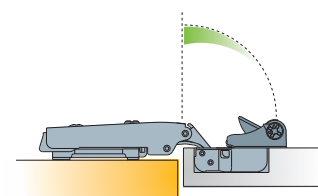

Adjustable damping zone

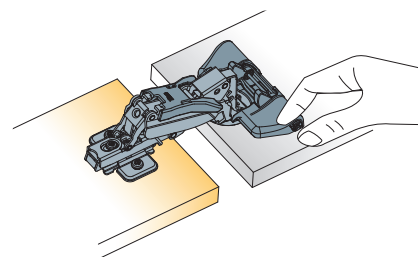

Turn towards '+' to increase and '-' to decrease the damping

#### Stand-alone soft closing solution

Glissando CR  
Glissando AL

Turn towards '+' to increase or towards '-' to decrease the damping.

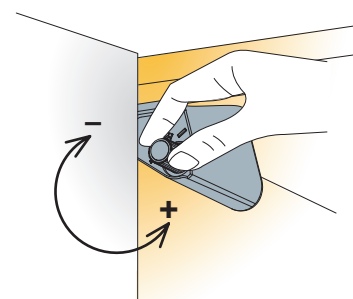

Damping adjustment

- Simple mounting
- Intuitive damping adjustment

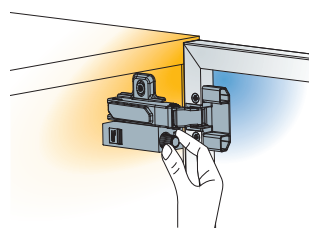

Turn towards '+' to increase and '-' to decrease the damping

# Glissando TT

## Glissando TL3

### Add-on Hinge Damper

For 95°, 110° and 120° hinges

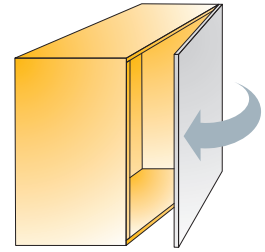

Technical details

Hinge opening angle

Item number

Glissando TT  
 · T-type 95  
 · T-type 110  
 · T-type 120

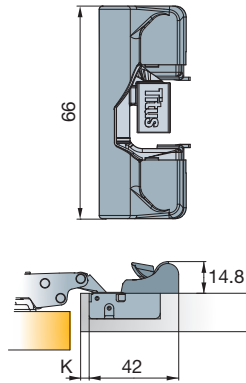

 200 Pcs    Made of steel and plastic

95°, 110°, 120°

729-0K71-054

Glissando TL3  
 · S-type 110  
 · B-type 110

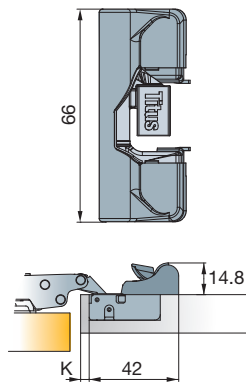

 200 Pcs    Made of steel and plastic

110°

951-0D45-054

- Same item can be used on most of crankings and angled hinges
- Intuitive snap-on mounting
- Low protrusion in cabinet interior
- Consistent performance across a broad range of furniture doors

Mounting details

Tool-less mounting

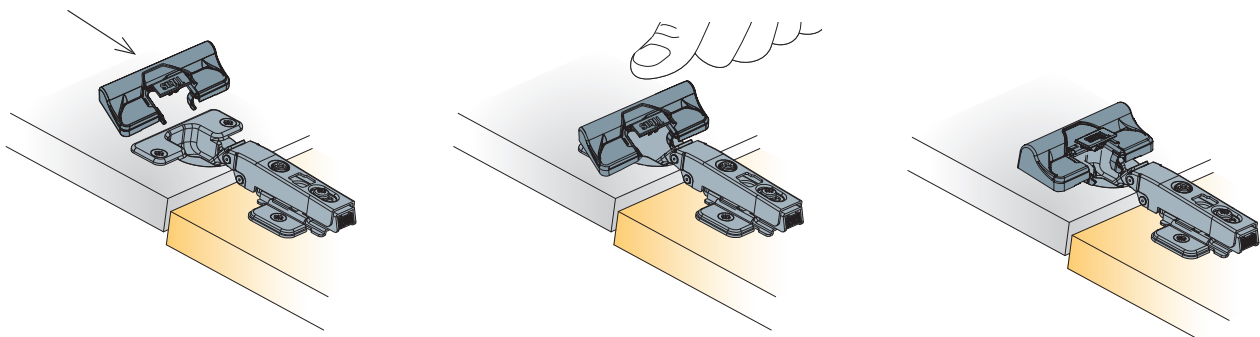

Insert Glissando TL3 into the holes on the hinge

Press down

Dismounting details

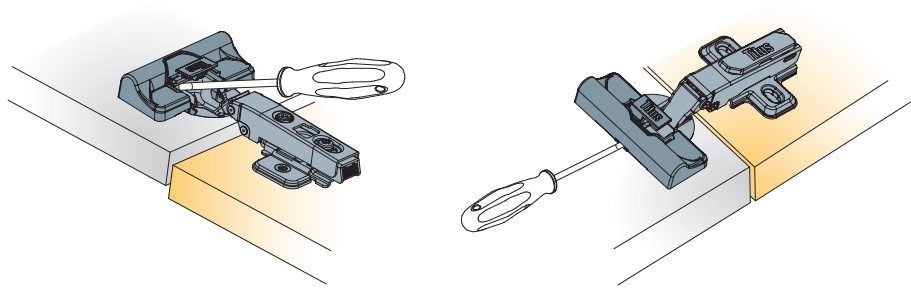

Use flat screwdriver

A trial mounting is always recommended.

Recommended number of Glissandos per door

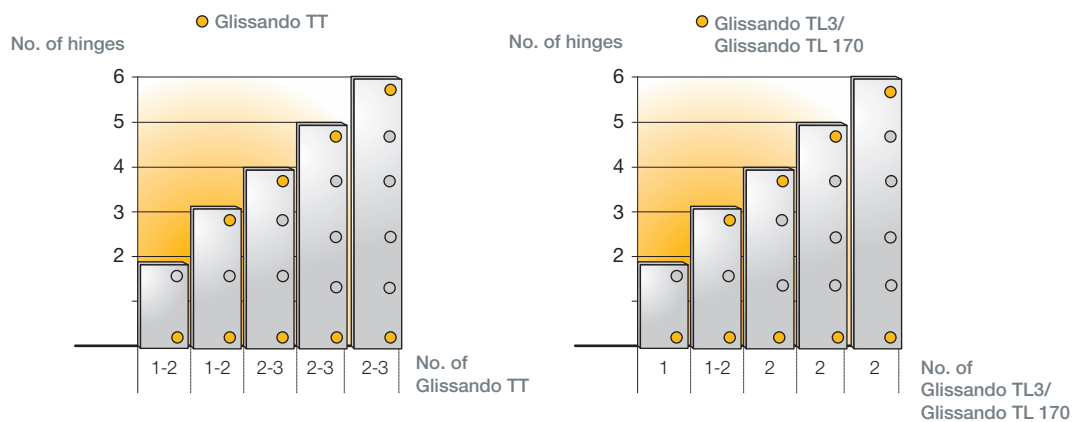

# Glissando TL 170

## Add-on Hinge Damper

For T-type 170, S-type 170 and B-type 170 hinges

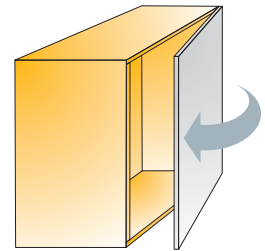
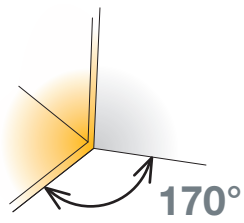

Technical details

Hinge opening angle	Item number
---------------------	-------------

Glissando TL 170

170° 951-0F15-650



Soft closing mechanism

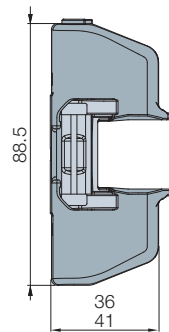

Box content  
100 pcs soft closing mechanisms  
100 pcs striking plates



Striking plate

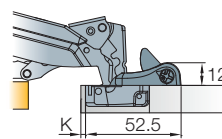

 100 Pcs    Made of steel, plastic and zinc

- Gentle and reliable soft closing on doors with wider opening angle
- Fits perfectly 45/9.5mm, 48/6mm and 52/5.5mm hinge cups
- ConfidentClose
- Tool-less mounting

Damping adjustment

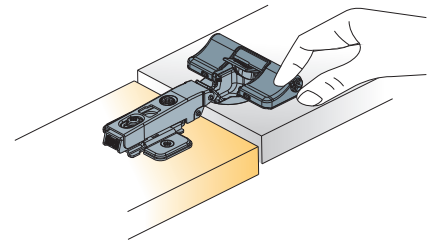

Turn towards '+' to increase and '-' to decrease the damping

Mounting details

Tool-less mounting

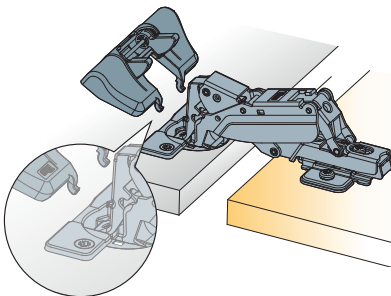

Insert Glissando TL 170 into the holes on the hinge cup

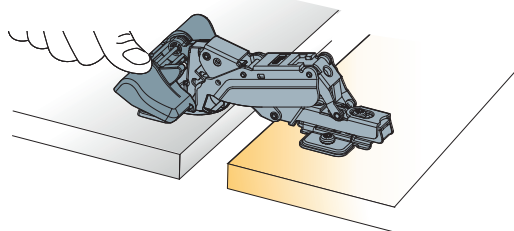

Press down

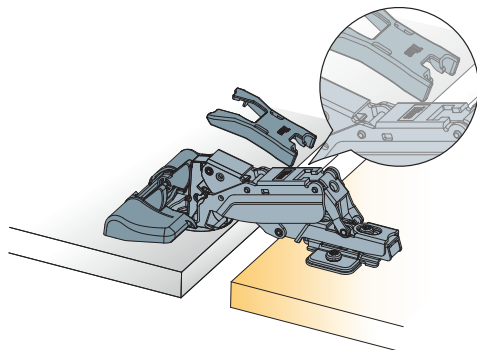

Place the striking plate into the hole on the hinge arm

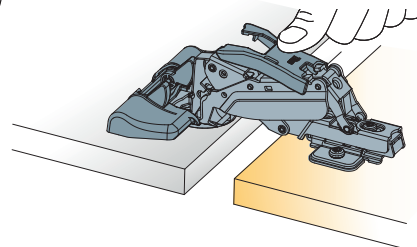

Press down

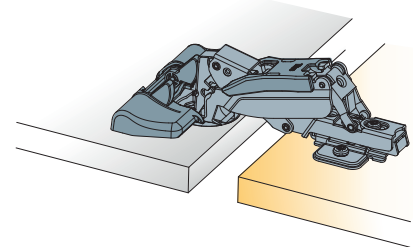

Recommended number of Glissandos per door

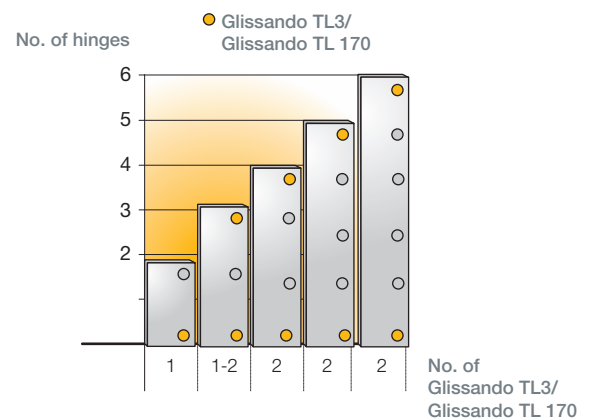

# Glissando AL

## Add-on Hinge Damper

For 20mm aluminium frame doors

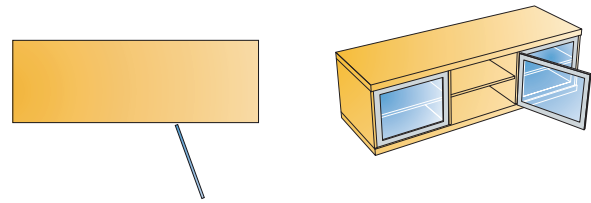

- Simple mounting
- Intuitive damping adjustment



Technical details

Item number

Grey

Glissando AL

972-0420 →

380

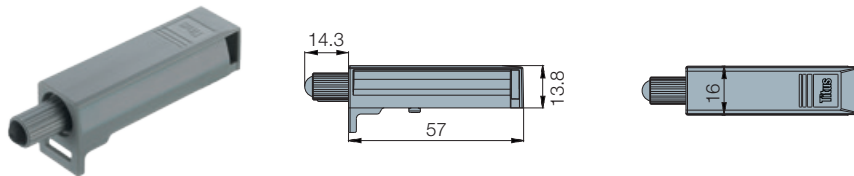

200 Pcs

Full overlay mounting plate

972-4564 →

380

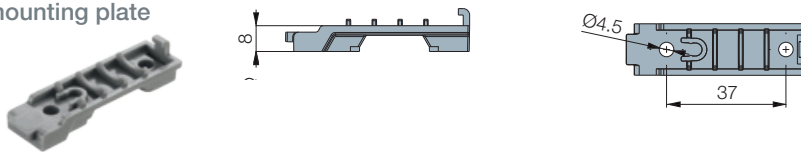

200 Pcs

Half overlay mounting plate

972-4565 →

380

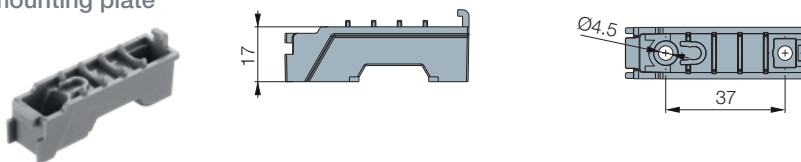

200 Pcs

Inset door mounting plate

972-4566 →

380

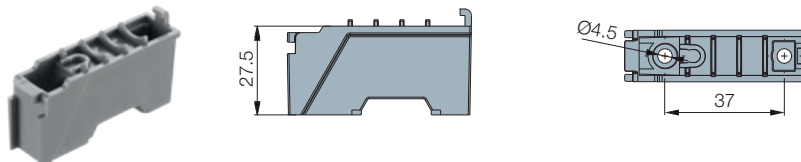

200 Pcs

Hinge cup screws  
If not pre-mounted

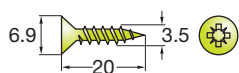

972-6344-042

1000 Pcs

- Simple mounting
- Intuitive damping adjustment
- Use with B-type AL hinges

#### Damping adjustment

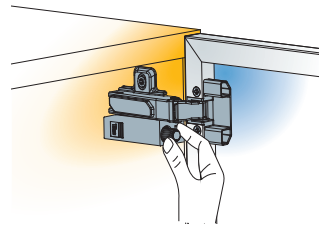

Turn towards '+' to increase and '-' to decrease the damping

#### Mounting procedure

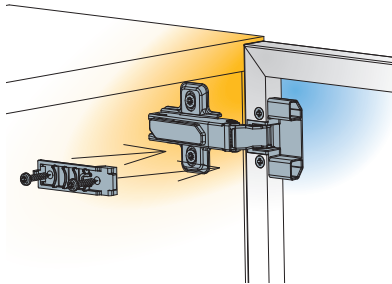

Position the mounting plate below the hinge arm and fix it with two screws. Use hinge mounting plate as a reference.

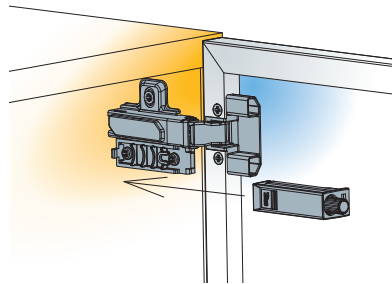

Slide Glissando AL onto the mounting plate.

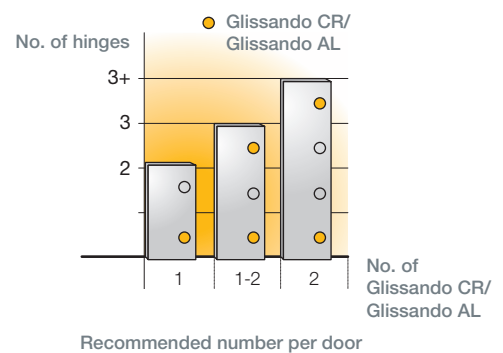
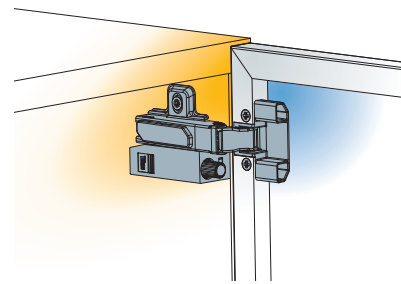

# Glissando CR

## Stand-alone Damper

For full overaly and half overaly  
concealed hinges

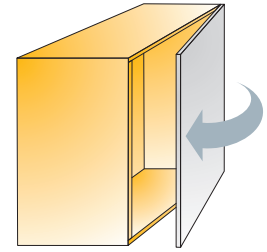

Technical details

Hinge opening angle	Cranking	Item number	White housing	Grey housing	Beige housing
---------------------	----------	-------------	---------------	--------------	---------------

Glissando CR  
for full overlay  
hinges



Nominal 11  
(Adjustment: Nominal + 5mm)

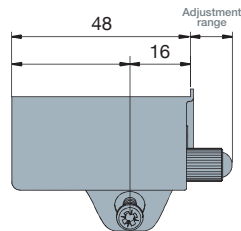

110°	0mm, 5mm	972-0X19 →	350	380	360
------	-------------	------------	-----	-----	-----

\*Fixing screw included in a set

100 Pcs Made of plastic

Glissando CR  
for half overlay  
hinges



Nominal 10  
(Adjustment: Nominal + 5mm)

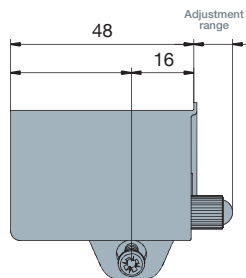

110°	9mm, 17mm	972-0X34 →		380	
------	--------------	------------	--	-----	--

\*Fixing screw included in a set

100 Pcs Made of plastic

- Intuitive 'place and fix' installation in the corner of the cabinet
- Tool-less damping adjustment
- One item for a wide range of doors
- Reliable performance
- Can be paired with all self-closing hinges

Damping adjustment

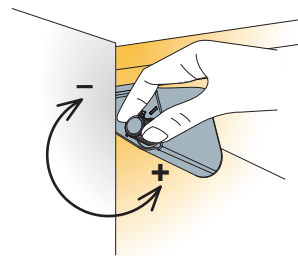

Turn towards '+' to increase and towards '-' to decrease the damping

Mounting details

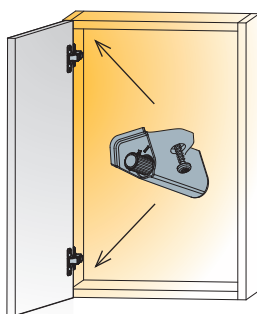
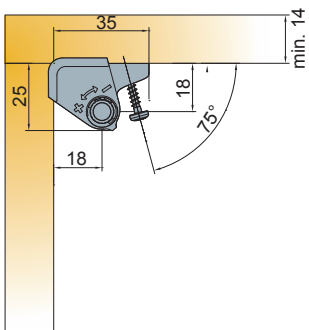

Mount Glissando CR on the hinged side of the cabinet

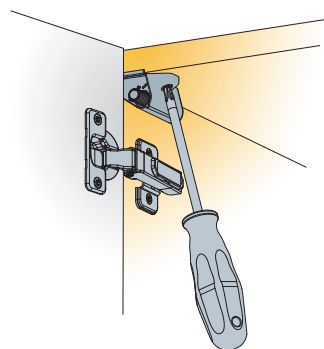

One screw fixing

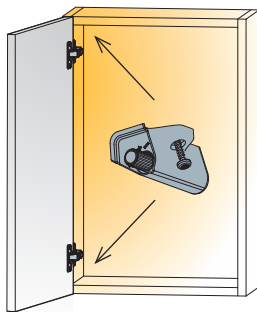
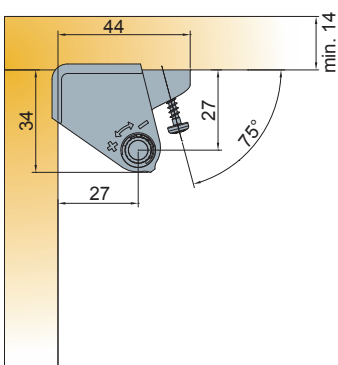

Mount Glissando CR on the hinged side of the cabinet

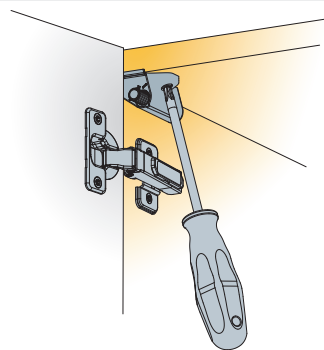

One screw fixing



The functioning of Glissando CR depends of the hinge's closing force. A trial mounting is always recommended.

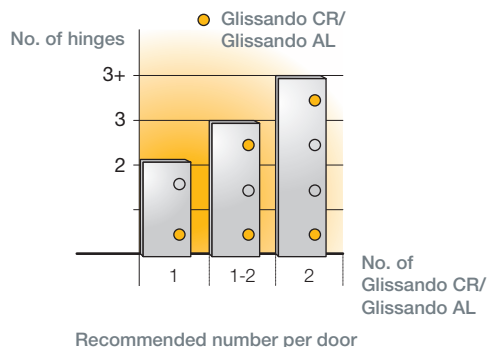

# TouchControl Solutions



## Push Latch S3

- Soft push opening system controls the outward motion for smooth, silent, and bounceless door movement
- Integrated damper ensures a soft landing, protecting the cabinet and enhancing user comfort

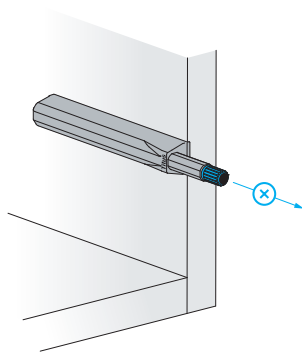

## Built-in SafeGuard

- For enhanced safety, adjustment button can't be removed
- Prevents from misuse



## Noir, elegant and discreet dark finish

- Seamless integration of hardware into the furniture
- Uniform and discreet surface

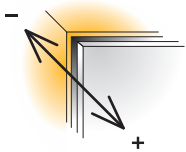

### Toolless door gap adjustment

- Easy to compensate any door gaps that might occur during installation
- Adjustment button designed for smooth, hand-operated adjustment



### Titus damper inside

- Push latch S2 and S3 version ensure controlled, soft and silent door opening
- Smooth user experience without door rebound
- Cushioned door landing

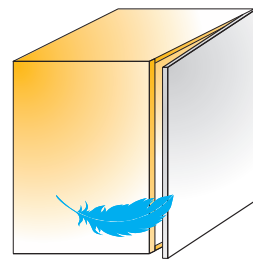

### Reliable performance

- Reliable door opening and closing through the life-time

# Push Latch S3

For all door types

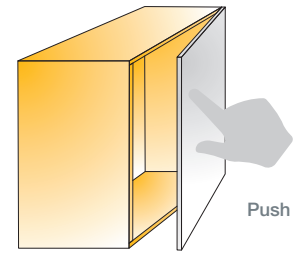

Technical details

Item number

Dusty white

Anthracite

Black

Push Latch S3 with housing

915-9277 →

356

383

390

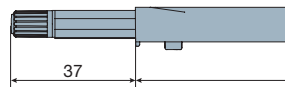
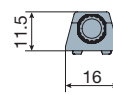

Linear mounting plate

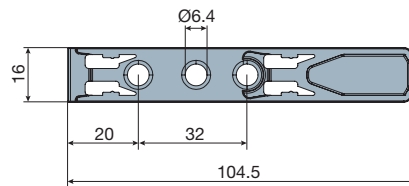

 200 Sets Made of plastic

Fixing screws for mounting plates

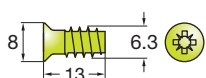

Euro screws  
821-6323-050

 5000 Pcs

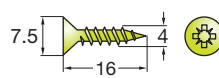

Chipboard screws  
820-6328-050

 10000 Pcs

- Soft and silent push opening
- Door gap adjustment ensures reliable closing and consistent performance
- 'Safety click' feature for easy detachment of the mechanism from its mounting plate
- Lip on the mounting plate assures accurate positioning

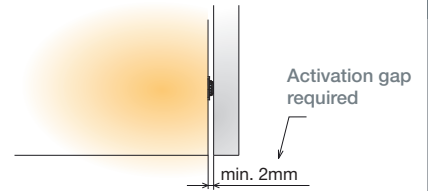
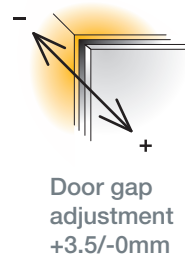

Drilling pattern

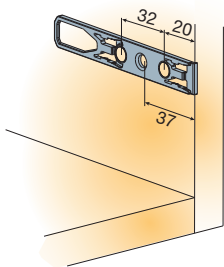

Mounting

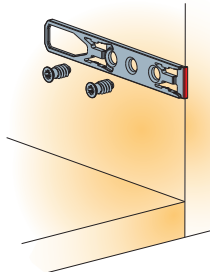

Depth adjustment

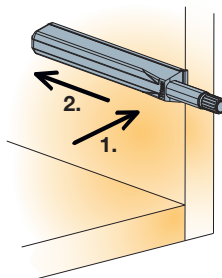
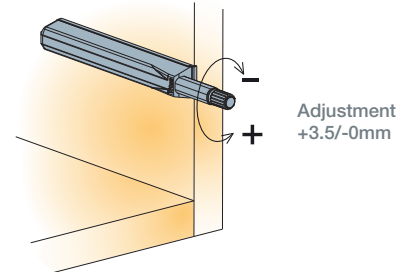

Positioning

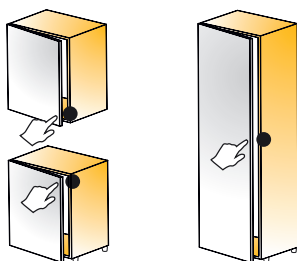

Mounting position close to the 'touch opening point' on the side opposite to hinges.

For application on cabinets with more than 2 hinges and cabinets with narrow doors we recommend a trial mounting.

# Push Latch S3

For wood doors

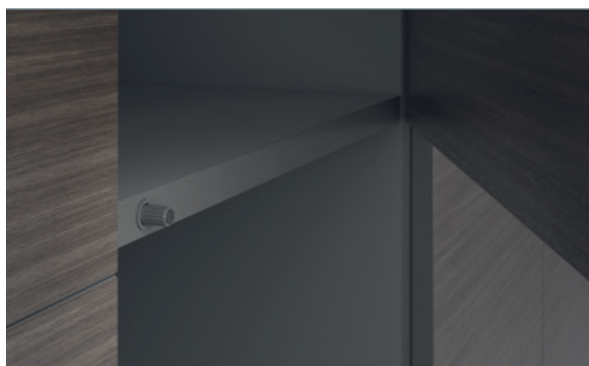
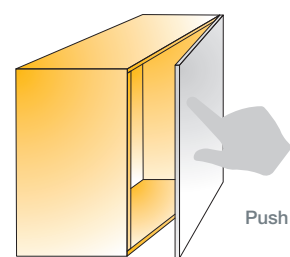

Tehnicl details

Item number

Dusty white

Anthracite

Black

Push Latch S3 drill-in

915-9276 →

356

383

390

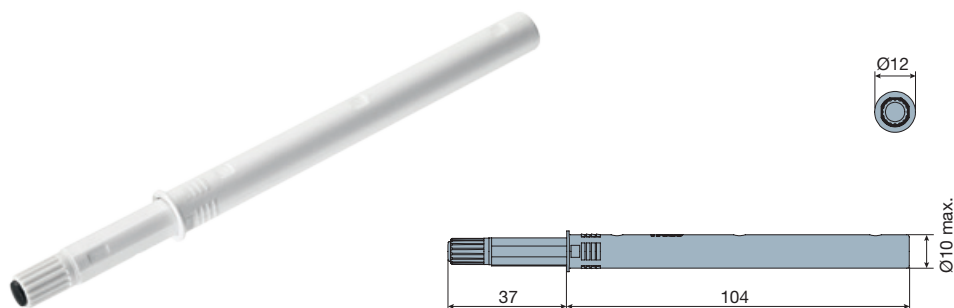

200 Pcs Made of plastic

Push Latch S3 routed

915-9278 →

356

383

390

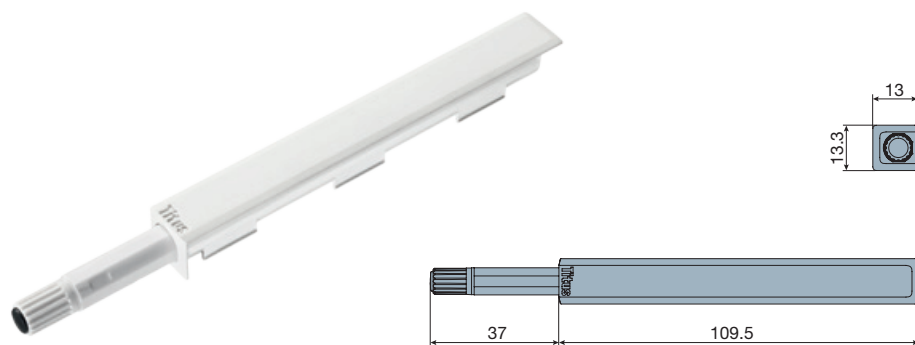

200 Sets Made of plastic

Drilling jig for Push Latch S3 drill-in



915-9900-072

1 Pc

- Soft and silent push opening
- Door gap adjustment ensures reliable closing and consistent performance
- Positioning lip assures accurate position

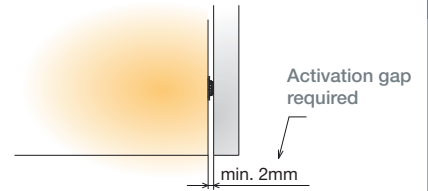
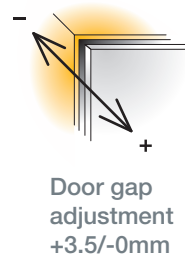

Drilling pattern

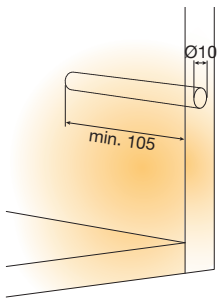

Mounting

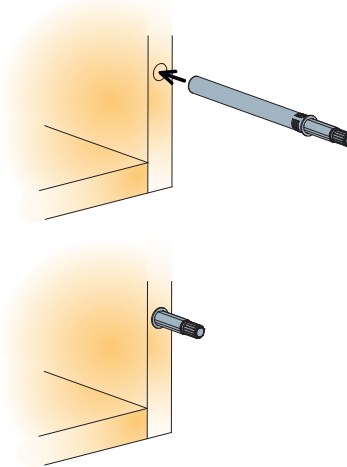

Depth adjustment

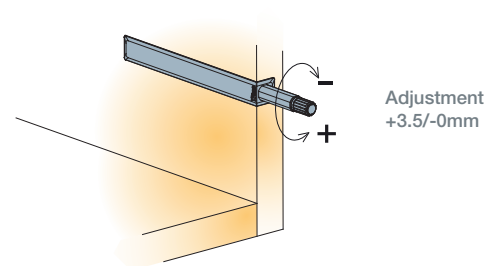
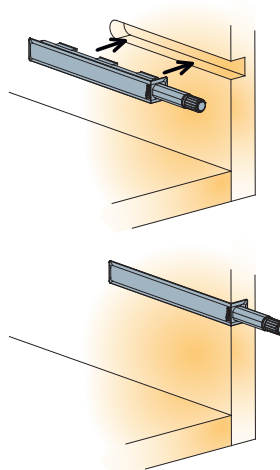
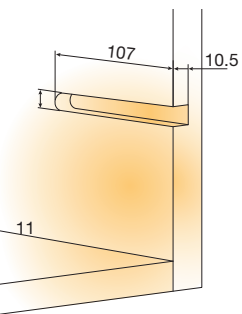
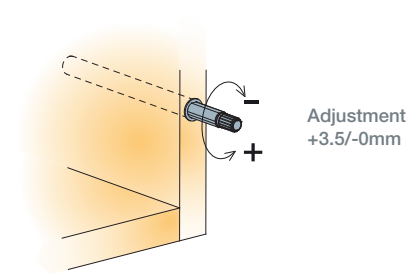

Positioning

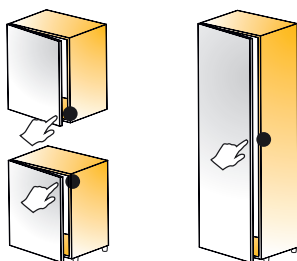

Mounting position close to the 'touch opening point' on the side opposite to hinges.

For application on cabinets with more than 2 hinges and cabinets with narrow doors we recommend a trial mounting.

# Push Latch S2

For wood doors

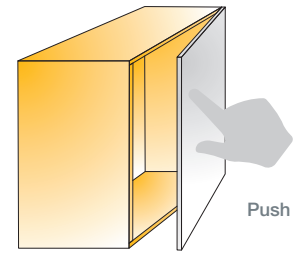

Push Latch S2

Item number

Silver grey

915-0W34 →

381

Set consists of:



200 Sets



Push Latch S2



Linear mounting plate with lip

200 Sets Made of steel and plastic

Fixing screws for mounting plates

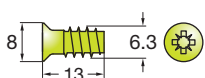

Euro screws  
821-6323-050

5000 Pcs

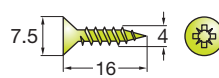

Chipboard screws  
820-6328-050

10000 Pcs

- Bounceless and reliable door opening and closing
- Safety detachment feature of the mechanism from its mounting plate
- Depth adjustment assures reliable and consistent push-to-open action
- Compatibility with damped or non-damped hinges ensures soft landing of the door

**i** Push latch S2 works with standard hinges with and without damping

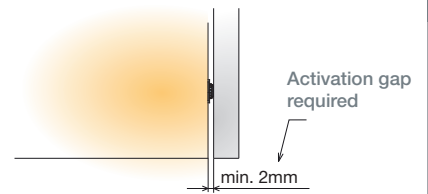
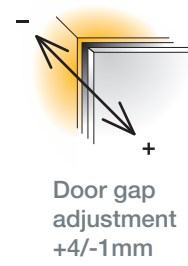

Drilling pattern

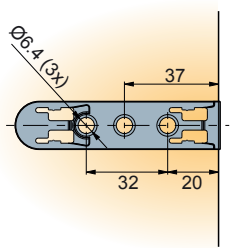

Mounting

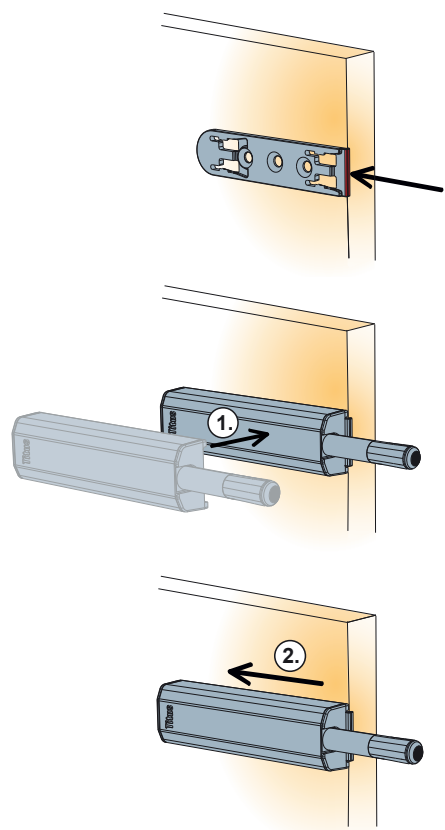

Depth adjustment

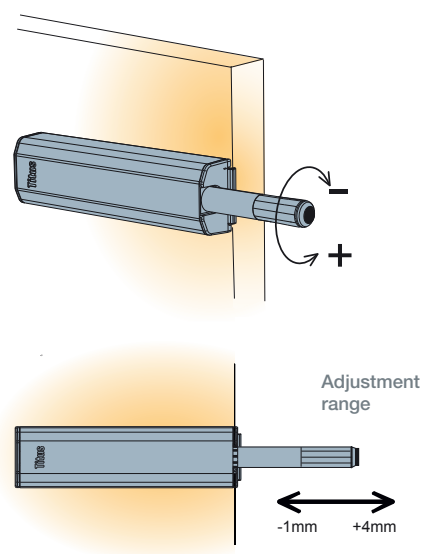

Positioning

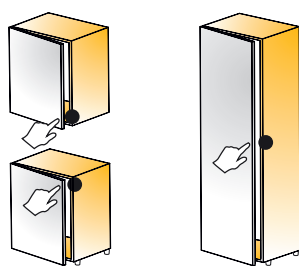

Mounting position close to the 'touch opening point' on the side opposite to hinges.

For application on cabinets with more than 2 hinges and cabinets with narrow doors we recommend a trial mounting.

# Push Latch

For wood doors and drawers

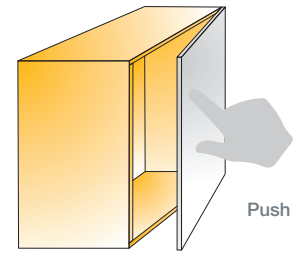

Push Latch



Push Latch



Cruciform mounting plate



Linear mounting plate

	Spring force [N] (released)	Spring force [N] (loaded)	Item number	Silver grey
With bumper	10	20	915-0X59 →	381
With bumper	13	27	915-0320 →	381
With magnet	10	20	915-0D22 →	381
Linear mounting plate			915-4175 →	381
Cruciform mounting plate			915-4183 →	381
<b>Sets:</b>				
	Cruciform m. plate		Linear m. plate	
With bumper	915-0X59-381-K1		915-0X59-381-K2	
	200 Sets		200 Sets	
With magnet	915-0D22-381-K1		915-0D22-381-K2	
	200 Sets		200 Sets	

200 Pcs    Made of steel and plastic

## Fixing screws for mounting plates

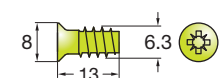

Euro screws  
821-6323-050  
 5000 Pcs

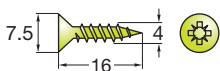

Chipboard screws  
820-6328-050  
 10000 Pcs

## Accessories for Push latch with magnet (nickel plated steel)

### Counter plate self adhesive

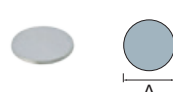

A = Ø15

915-7159-050 500 Pcs

### Counter plate

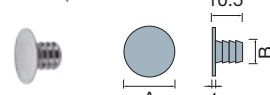

A = Ø10 B = Ø5

915-7196-050 500 Pcs

A = Ø15 B = Ø8

915-7190-050 500 Pcs

### Knock-in Counter plate

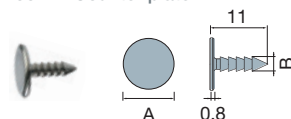

A = Ø10 B = Ø2.8

915-7199-050 500 Pcs

- Effortless opening with just a light touch
- Depth adjustment ensures reliable closing and consistent performance in case of inaccurate drilling
- 'Safety click' feature for easy detachment of the mechanism from its mounting plate

**i** Push latch with bumper works with standard hinge  
 Push latch with magnet works with reverse spring hinges or unsprung hinges

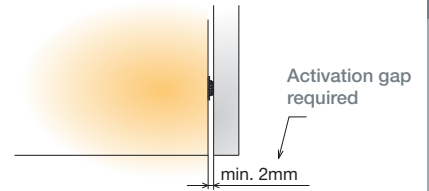
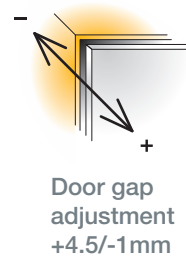

Drilling pattern

Dimensions

Depth adjustment

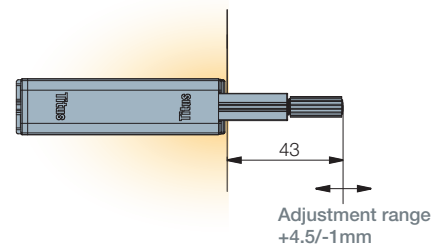
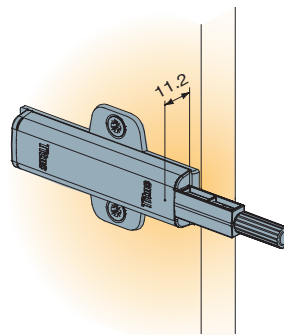
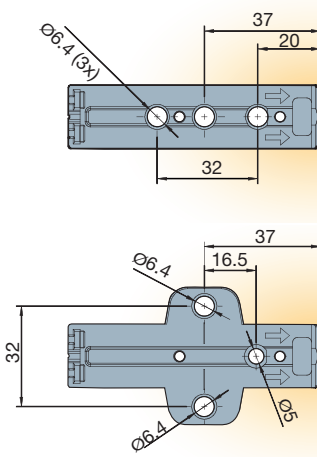

Positioning

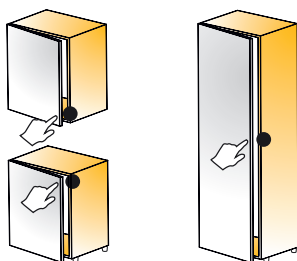

Mounting position close to the 'touch opening point' on the side opposite to hinges.

For application on cabinets with more than 2 hinges and cabinets with narrow doors we recommend a trial mounting.

# PushOpen Short

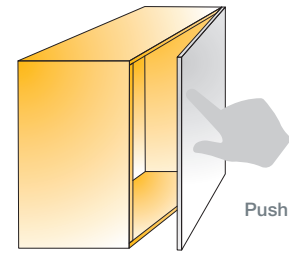

Stroke [mm]	Item number	White	Grey	Lead grey	Black
-------------	-------------	-------	------	-----------	-------

## PushOpen Short

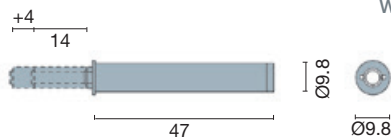

With bumper

14	<b>915-7187</b> →	350	380	383	390
----	-------------------	-----	-----	-----	-----

With magnet

14	<b>915-7185</b> →	350	380	383	390
----	-------------------	-----	-----	-----	-----

100 Pcs Made of steel and plastic

## Housing Short

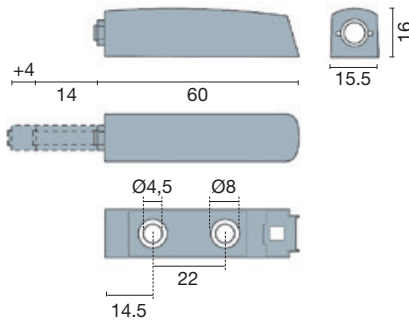

<b>915-7192</b> →	350	380	383	390
-------------------	-----	-----	-----	-----

100 Pcs Made of plastic

### Fixing screws for housing

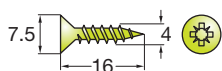

Chipboard screws  
**820-6328-050**  
10000 Pcs

### Accessories for PushOpen with magnet (nickel plated steel)

#### Counter plate self adhesive



A = Ø15 **915-7159-050** 500 Pcs

#### Counter plate

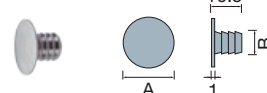

A = Ø10 B = Ø5 **915-7196-050** 500 Pcs

A = Ø15 B = Ø8 **915-7190-050** 500 Pcs

#### Knock-in Counter plate

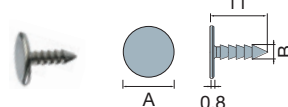

A = Ø10 B = Ø2.8 **915-7199-050** 500 Pcs

- Effortless opening with just a light touch
- Depth adjustment ensures reliable opening



PushOpen with bumper works with standard hinge  
 PushOpen with magnet works with reverse spring or unprung hinges

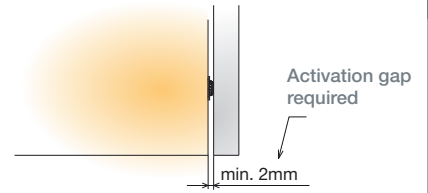
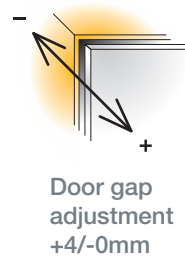

Drilling pattern and mounting procedure

Depth adjustment

Door gap adjustment

Without housing

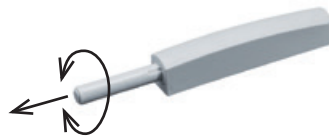
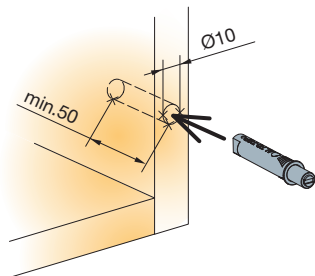

Adjustment made by rotating the depth adjustment screw

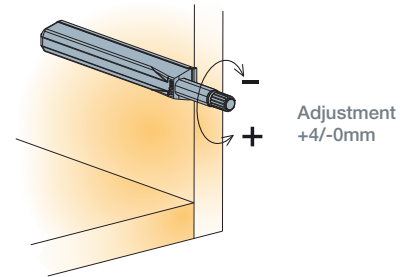

With housing

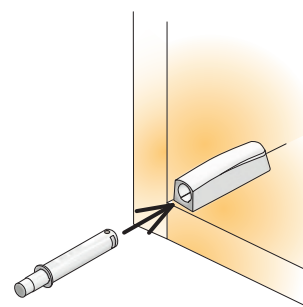
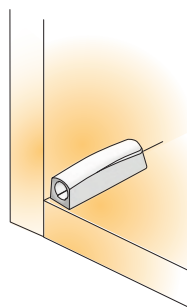
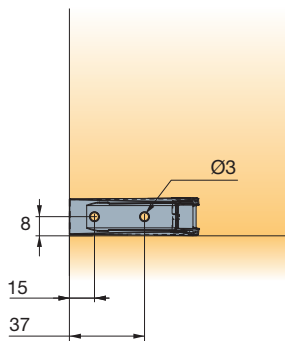

Application on door for Counter plates

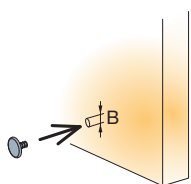

Pre-drilled hole ØB x 10mm

Application on door for Counter plate with double side tape and knock-in counter plate

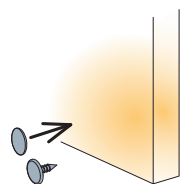

Sticking or knock-in position

Positioning

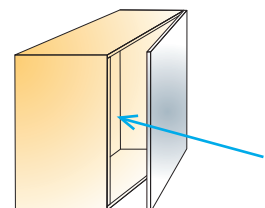

Close to the 'touch opening point' on the side opposite to hinges

# PushOpen Long

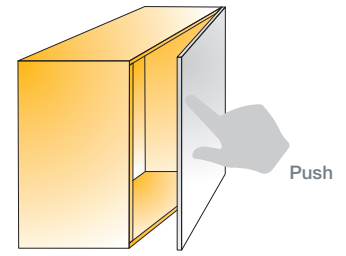

Stroke [mm]	Item number	White	Grey	Lead grey	Black
-------------	-------------	-------	------	-----------	-------

PushOpen  
Long

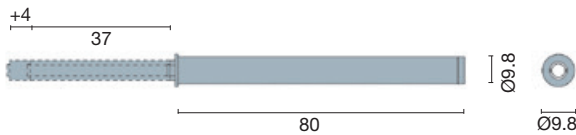

With bumper

37 **915-7188** → 350 380 383 390

With magnet

37 **915-7186** → 350 380 383 390

100 Pcs Made of steel and plastic

Housing  
Long

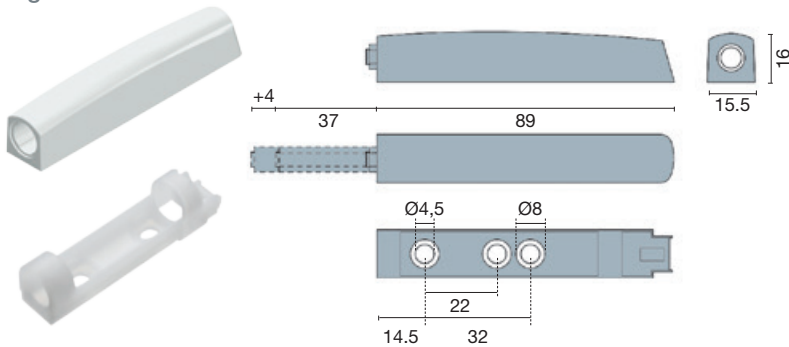

**915-7193** → 350 380 383 390

100 Pcs Made of plastic

Fixing screws for housing

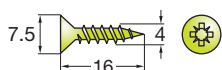

Chipboard screws  
**820-6328-050**

10000 Pcs

Accessories for PushOpen with magnet (nickel plated steel)

Counter plate self adhesive



A = Ø15

**915-7159-050** 500 Pcs

Counter plate

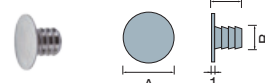

A = Ø10 B = Ø5

**915-7196-050** 500 Pcs

A = Ø15 B = Ø8

**915-7190-050** 500 Pcs

Knock-in Counter plate

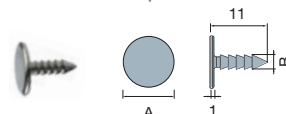

A = Ø10 B = Ø2.8

**915-7199-050** 500 Pcs

- Effortless opening with just a light touch
- Depth adjustment ensures reliable opening



PushOpen with bumper works with standard hinge  
 PushOpen with magnet works with reverse spring or unprung hinges

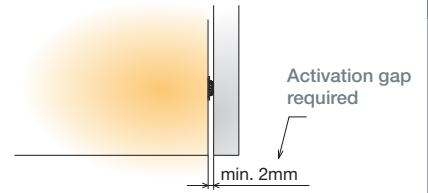
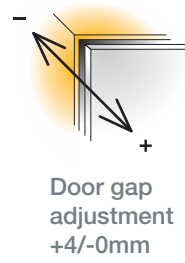

Drilling pattern and mounting procedure

Depth adjustment

Door gap adjustment

Without housing

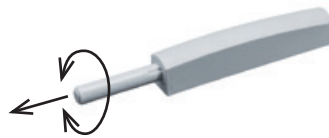
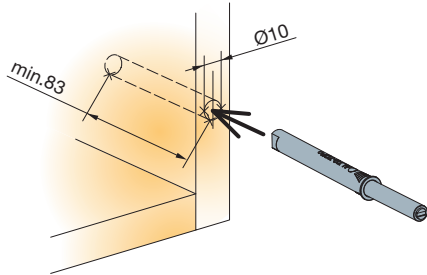

Adjustment made by rotating the depth adjustment screw

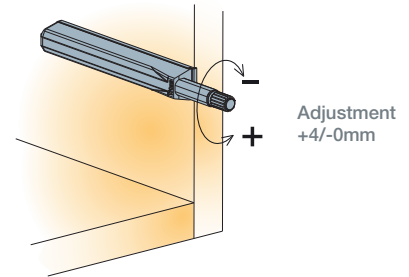

With housing

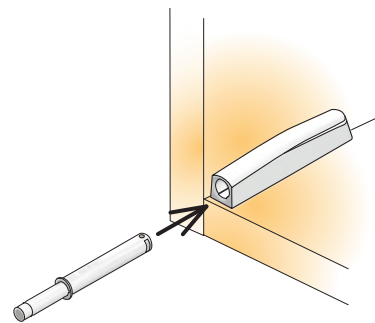
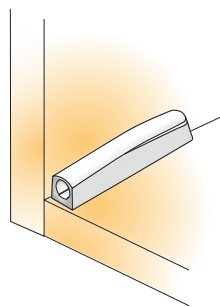
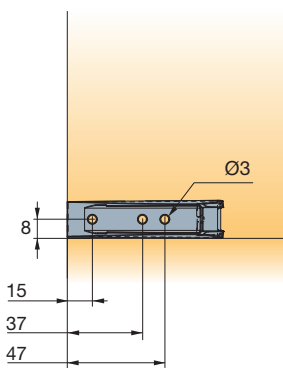

Application on door for Counter plates

Application on door for Counter plate with double side tape and knock-in counter plate

Positioning

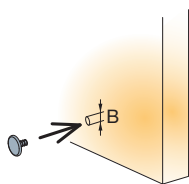

Pre-drilled hole  
 ØB x 10mm

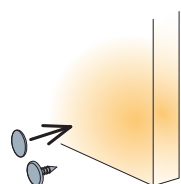

Sticking or knock-in position

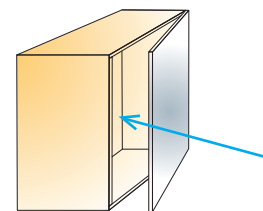

Close to the 'touch opening point' on the side opposite to hinges



# Tekform Slimline+ Drawer

# Tekform Slimline+ Drawer

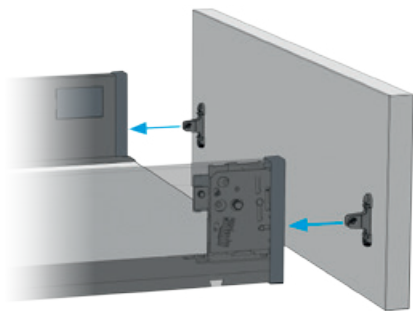

## Swift assembly with enhanced front panel engagement

- Improved front panel connection ensures secure engagement and effortless disengagement

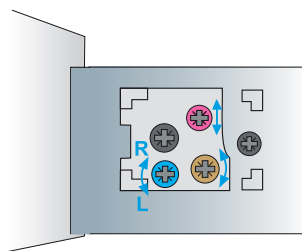

## 3D drawer front alignment with easy access

- Convenient front access for side, height, and tilt adjustment
- Colour-coded adjustment cams for easy identification
- Ensures uniform gap layouts for evenly aligned drawer fronts

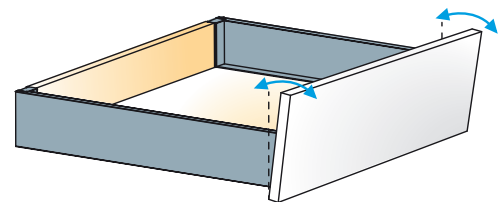

## Tilt adjustment

- Accessible at the front of the drawer side
- For an intuitive drawer front positioning through the mechanical stop



### Smooth and effortless performance

- Titus Damper Inside with ART function for smooth and controlled movement, regardless of the closing speed
- Low pull-out force
- Optimal closing performance and life-long consistent damping

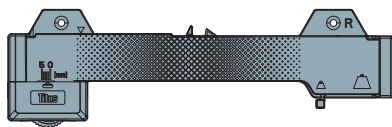

### Push-to-open compatibility for handleless cabinets

- Intuitive mounting without pre-drilling
- One-for-all: one mechanism for all Tekform Slimline+ drawers from 350mm onwards
- Easily adjustable push-to-open activation with only 1.5mm gap to operate
- Same runner for standard and push-to-open application

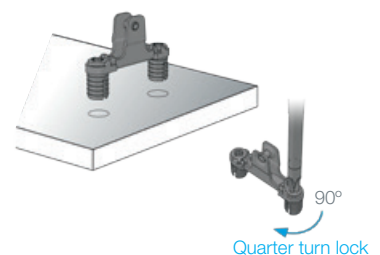

### EasyFix front panel attachment

- Simple hand insertion
- Comfortable locking action at 90° turn of screwdriver
- Expando function for firm and reliable front attachment

# Tekform Slimline+ Drawer

## Product Guide

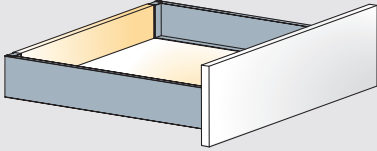
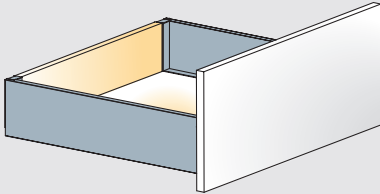
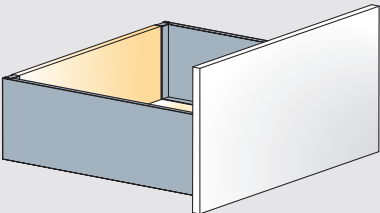
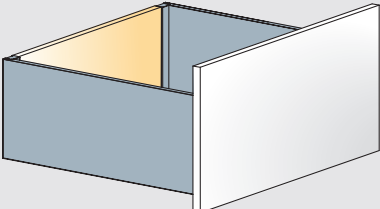
				Page
<b>Tekform Slimline+ Drawer</b>		Side material	Drawer type	
Tekform Slimline+ drawer DW70		Metal	Soft closing Push-to-open compatible	3.13
Tekform Slimline+ drawer DW100		Metal	Soft closing Push-to-open compatible	3.15
Tekform Slimline+ drawer DW145		Metal	Soft closing Push-to-open compatible	3.17
Tekform Slimline+ drawer DW182		Metal	Soft closing Push-to-open compatible	3.19

Page

## Inner Drawer Front for Tekform Slimline+ Drawer

Inner drawer front for Tekform Slimline+ Drawer DW70

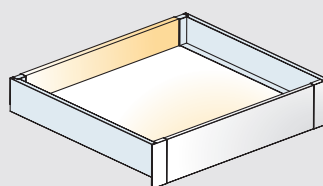

3.21

Inner drawer front for Tekform Slimline+ Drawer DW145 with bar

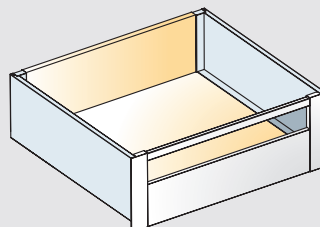

3.23

Inner drawer front for Tekform Slimline+ drawer DW182 with bar

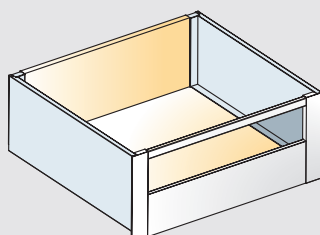

3.25

## Accessories

Tacto 2.0	3.27
Marking jig	3.28
Steel back panel	3.29

## Tekform Slimline Drawer

Tekform Slimline drawer DW45

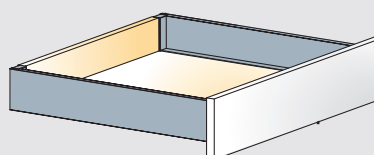

Side material

Drawer type

Metal

Soft closing  
Push-to-open compatible

3.31

# Tekform Slimline+ Drawer Information

## Technical Guide

### How to choose the appropriate drawer dimension?

Select the drawer size based on the available cabinet space. Please refer to the chart below, which indicates the

minimum space required in the cabinet to choose the appropriate drawer system.

NL = Tekform Slimline+ drawer nominal length (mm)

NL	270	300	350	400	450	500	550
----	-----	-----	-----	-----	-----	-----	-----

	Tekform Slimline+ drawer	
	Min. height H required	Cabinet depth D
<b>Tekform Slimline+ drawer DW70</b>	115mm	NL + min. 3mm
<b>Tekform Slimline+ drawer DW100</b>	147mm	NL + min. 3mm
<b>Tekform Slimline+ drawer DW145</b>	198mm	NL + min. 3mm
<b>Tekform Slimline+ drawer DW182</b>	230mm	NL + min. 3mm

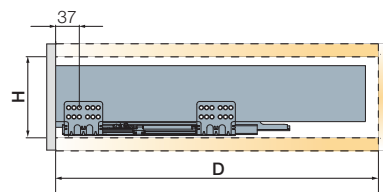

### How to fix drawer sides to the front panel?

The Tekform Slimline+ drawer is available with EasyFix or screw-in front connectors



#### Screw-in front connector

- reliable connection
- fixing with Ø3.5x15mm screws (screws are not included)

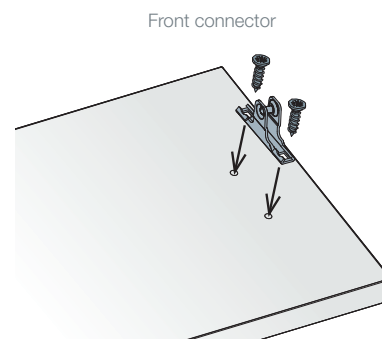

#### EasyFix front connector

- hand insertion
- quarter turn locking system
- expandable dowel
- easy assembly and disassembly of front panel

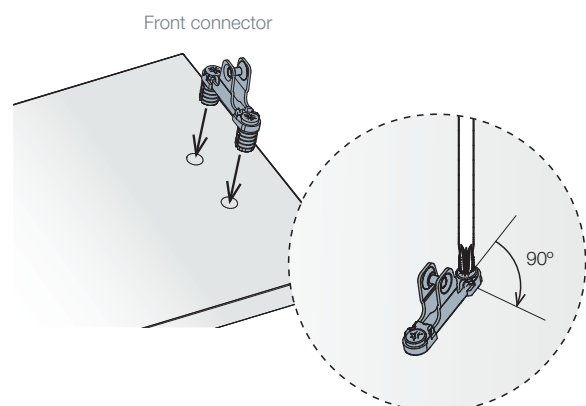

## Planning

### Bottom panel and back panel cutting dimensions

Dimensions of bottom and back panel depends on:

- cabinet width
- nominal drawer length
- drawer height

NL = Tekform Slimline+ drawer nominal length (mm)

NL	270	300	350	400	450	500	550
----	-----	-----	-----	-----	-----	-----	-----

Cabinet width

ECW: External cabinet width  
ICW: Internal cabinet width  
NL: Nominal length of drawer

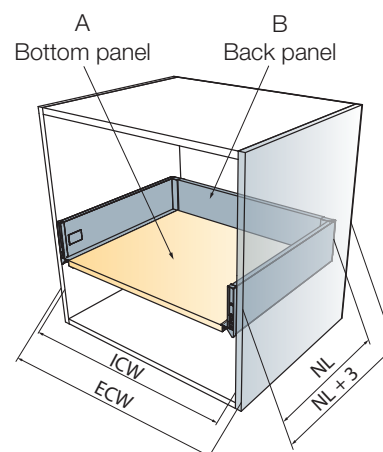

### Back panel cutting dimensions

Back panel height depends on the selected drawer height

	K
<b>DWD70</b>	68
<b>DWD100</b>	100
<b>DWD145</b>	151
<b>DWD182</b>	183

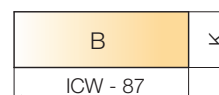

### Bottom panel cutting dimensions

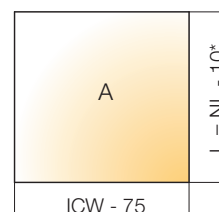

NL	270	300	350	400	450	500	550
<b>L</b>	260	290	340	390	440	490	540
<b>L<sub>st</sub></b>	250	280	330	380	430	480	530

NL = Slimline+ drawer nominal length (mm)

L = Length in case of wood back panel

L<sub>st</sub>: Length in case of steel back panel

\*For drawers with steel back panel L = NL - 20

# Tekform Slimline+ Drawer Information

## Technical Guide

### How to choose the appropriate drawer runner fixing positions?

The drawer's fixing position depends on its functional placement.

### Tekform Slimline+ drawer front positioned outside the carcass

When the drawer front is positioned outside the carcass, use the third hole on the drawer runner for fixing.

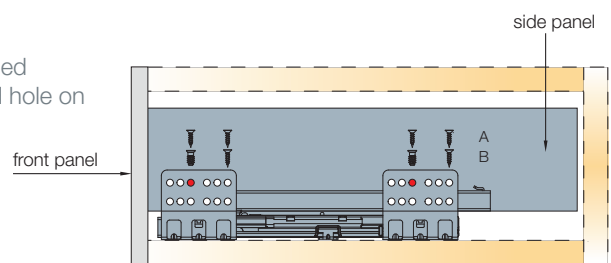

### Tekform Slimline+ drawer front positioned inside the carcass

When the drawer front is positioned inside the carcass, use the second hole on the drawer runner for fixing.

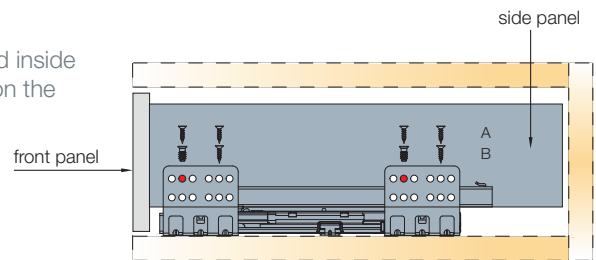

### Load capacity

Drawer load capacity is 40 kg.

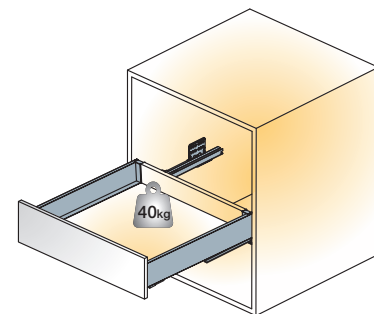

### Expanded tolerances

Tekform Slimline+ drawer provides wider tolerances in cabinet construction and assures:

- precise drawer alignment
- smooth and silent operation
- improved drawer stability in open position
- Tekform Slimline+ drawer provides a tolerance of +/- 1mm on bottom panel width size

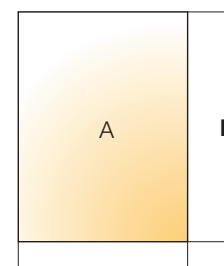

bottom panel width tolerance +/- 1mm



Adjustment needs to be done on both sides of the drawer

## Adjustments

### How to adjust the drawer front panel?

The Tekform Slimline+ drawer offers effortless three-dimensional front panel alignment, providing convenient access for side, height, and tilt adjustment positioned

at the front of the drawer side. Enhanced with colour-coded adjustment cams, for easy identification and precise alignment, guaranteeing uniform gap layouts.

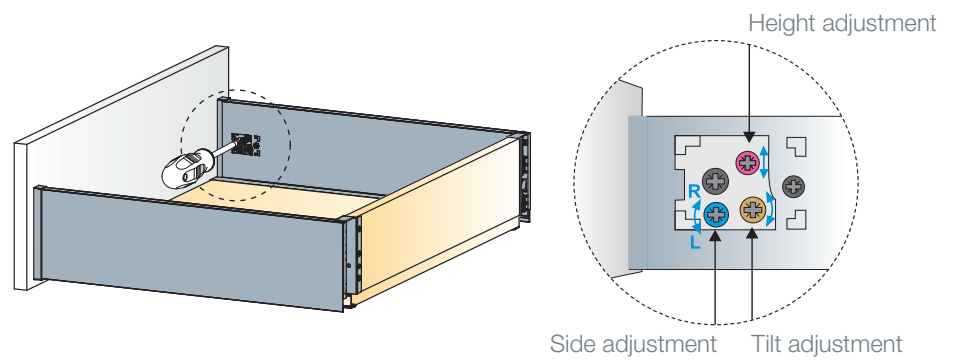

### Side adjustment

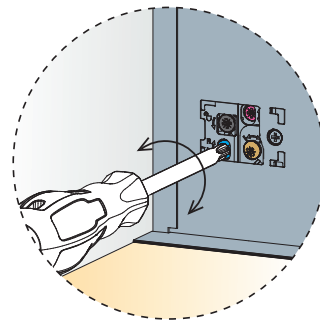
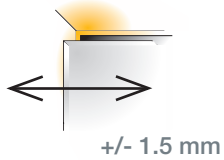

Side adjustment is done by rotating the grey coloured cam adjuster on the drawer side.

### Height adjustment

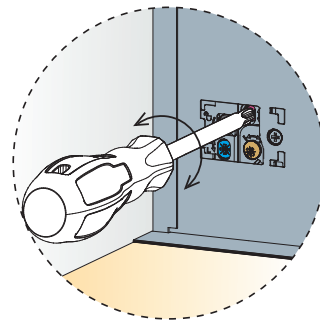
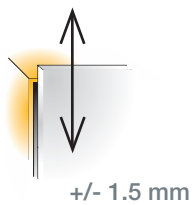

Height adjustment is done by rotating the red coloured cam adjuster on the drawer side.

### Tilt adjustment

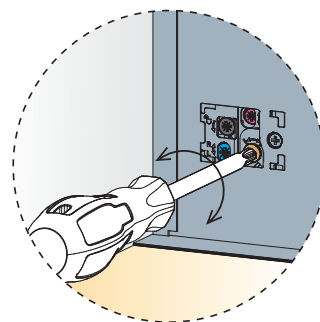
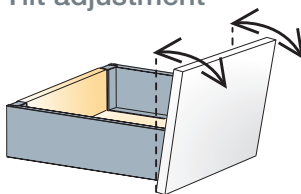

Tilt adjustment is done by rotating the yellow coloured cam adjuster on the drawer side.

# Tekform Slimline+ Drawer Information

## Key Design Choices

### ConfidentClose

Fast closing

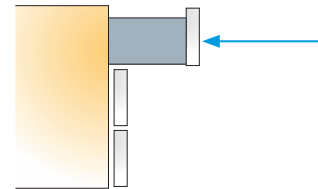

Late start of damping

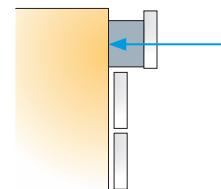

Quiet landing

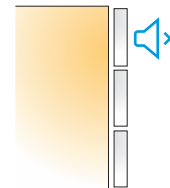

### CAF Consumer Assembly Friendliness

EasyFix front panel connector with expandable dowels provides:

- Quick, toolless insertion
- Quarter turn lock
- Repeatable assembly and disassembly

Front connector

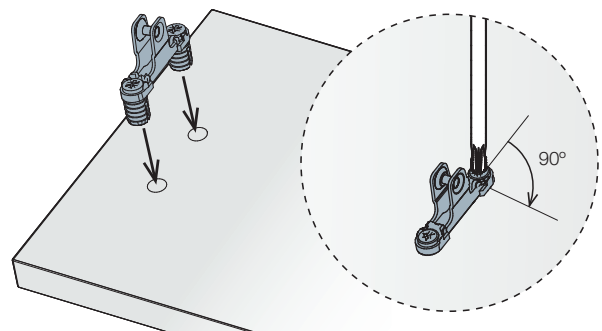

Compatible with Tacto push-opening system:

- For convenient, handle-free opening
- Same runner for both, standard and Tacto push-to-open applications
- The Tacto mechanism can be simply added as a retrofit option at any time after the drawer assembly
- For all drawers from a 300mm nominal length onwards

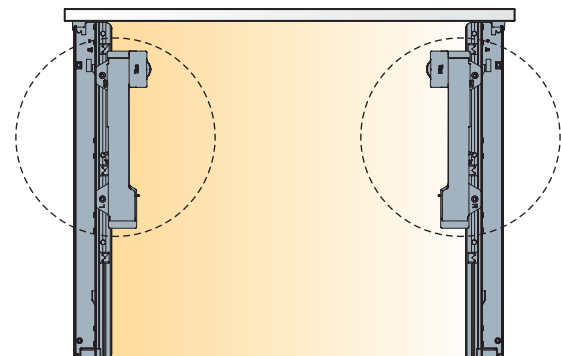

### Titus Damper inside

Designed and produced in-house

- Reliable and consistent lifelong damping
- Smooth closing
- Consistent damping performance guaranteed across high-volume production runs
- 100% automated quality check



### Damping action

Even and smooth soft closing action

- Soft and reliable closing

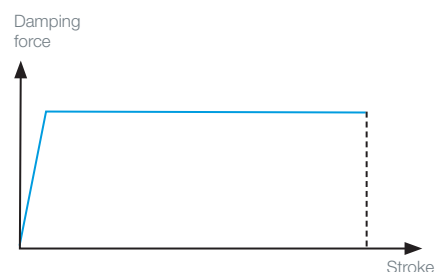

Flat damping curve shows the uniform action produced during damper closing at a defined speed.

### Response to speed

Response to speed defines the increase in damping force in relation to the closing speed of the damping object.

#### Standard

The damping force increase is approximately linear to the increasing speed of closing.

#### ART - Adaptive Response Technology

Adaptive Response Technology fine-tunes the damper's performance and damping force by adjusting to the drawer's weight and speed. It provides smooth and reliable damping at any closing speed, while reducing the force needed to open the drawer.

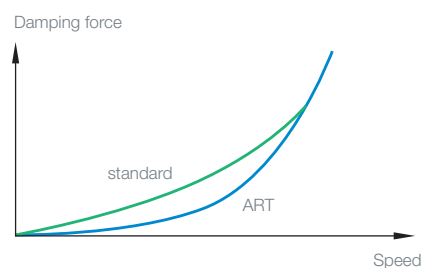

# Tekform Slimline+ Drawer DW70

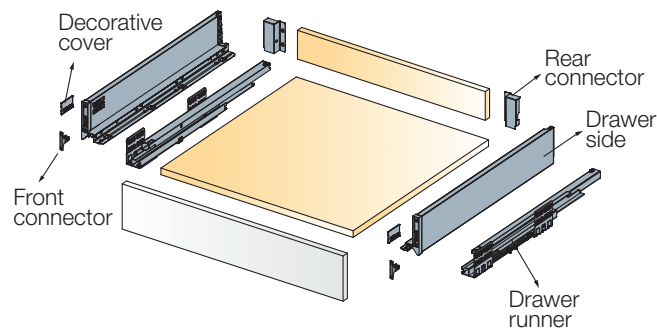
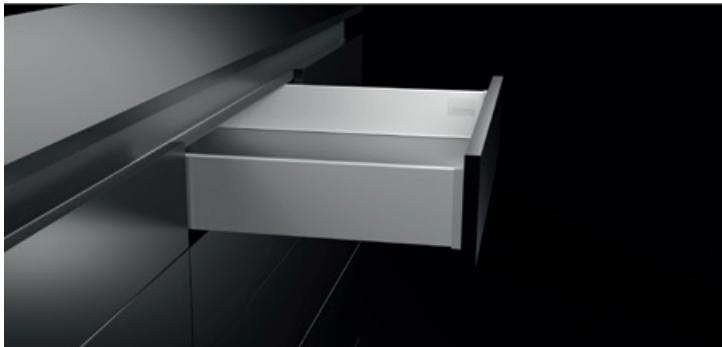
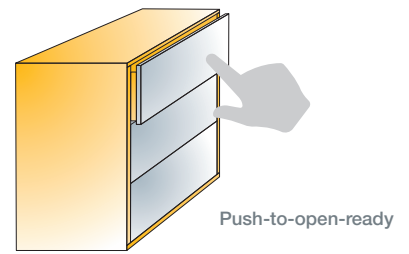

## Cutting dimensions details

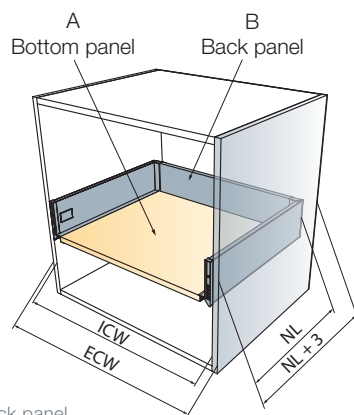

ECW: External cabinet width  
ICW: Internal cabinet width  
NL: Nominal length of drawer  
L<sub>st</sub>: Length in case of steel back panel

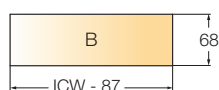
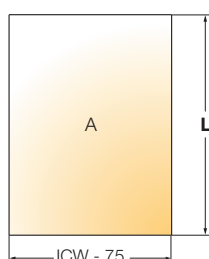

$L = NL - 10$   
 $L_{st} = NL - 20$   
For further explanation → see page 3.8



4 sets

Nominal length (mm)	with Screw-in front connector 		
		White	Anthracite
270	656-8352 →	150	185
300	656-8353 →	150	185
350	656-8354 →	150	185
400	656-8356 →	150	185
450	656-8357 →	150	185
500	656-8358 →	150	185
550	656-8359 →	150	185

## One set consists of

Drawer sides		2 pcs
Drawer runners		2 pcs
Front connectors		2 pcs
Rear connectors		2 pcs
Decorative covers		2 pcs
Mounting instructions		1 pc/4 sets

## Push opening



Tacto Slimline Mechanism  
→ see page 3.27

## EasyFix front connector



656-0H66-380-00

 400 Pcs

- Drawer runner type
- Load capacity
- Minimum height space required
- Drawer side thickness
- Wooden back panel thickness
- Wooden bottom panel thickness

full extension  
40 kg  
115mm  
14mm  
16mm  
16mm

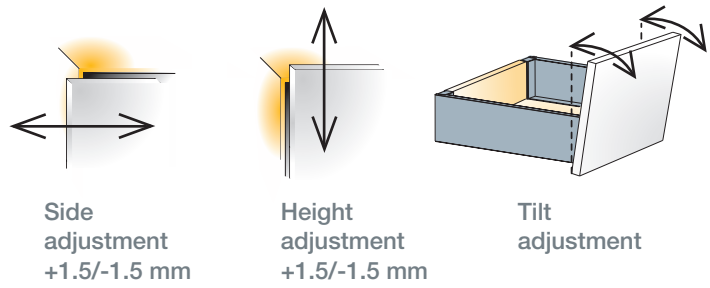

**i** Works with Tacto Push Opening Mechanism  
→ see page 3.27

For further explanation → see page 3.10

Installation dimensions and drillings

Drawer runner fixing positions

Front panel

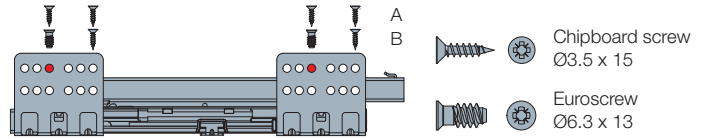
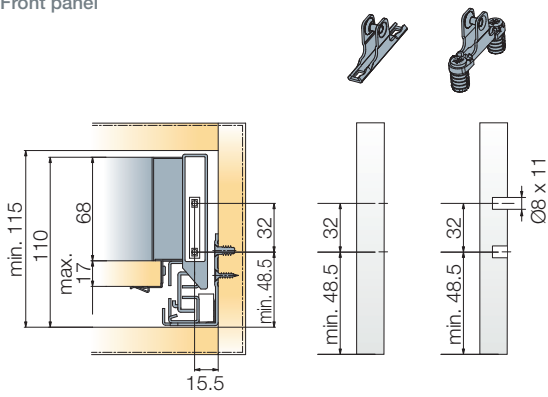

NL=270mm  
NL=300mm  
NL=350mm  
NL=400mm  
NL=450mm

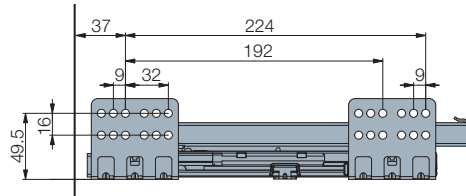

Back panel

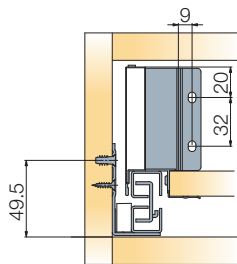

NL=500mm  
NL=550mm

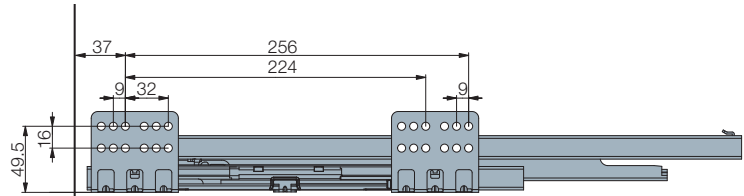

Assembly instructions, adjustments



# Tekform Slimline+ Drawer DW100

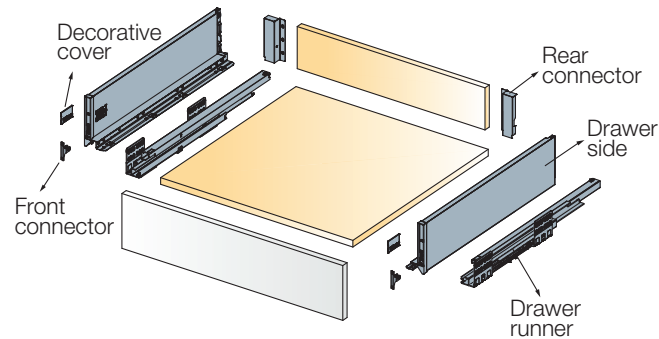
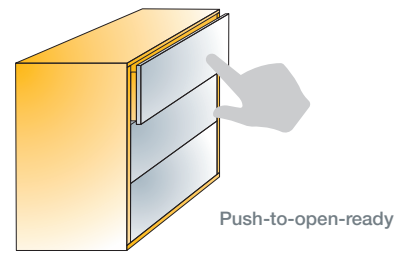

## Cutting dimensions details

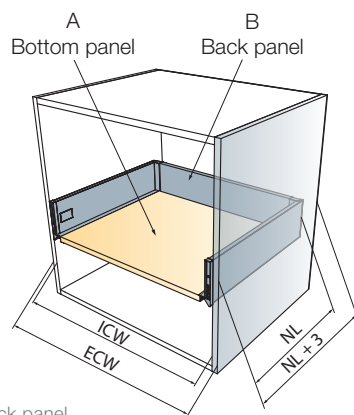

ECW: External cabinet width  
ICW: Internal cabinet width  
NL: Nominal length of drawer  
L<sub>st</sub>: Length in case of steel back panel

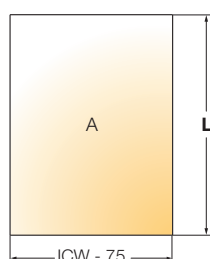







$L = NL - 10$   
 $L_{st} = NL - 20$   
For further explanation → see page 3.8

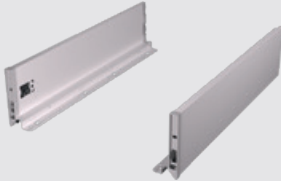

4 sets

NL	with Screw-in front connector 		
		White	Anthracite
Nominal length (mm)	Item number for a set		
270	656-8360 →	150	185
300	656-8361 →	150	185
350	656-8362 →	150	185
400	656-8363 →	150	185
450	656-8364 →	150	185
500	656-8365 →	150	185
550	656-8366 →	150	185

## One set consists of

Drawer sides		2 pcs
Drawer runners		2 pcs
Front connectors		2 pcs
Rear connectors		2 pcs
Decorative covers		2 pcs
Mounting instructions		1 pc/4 sets

## Push opening



Tacto Slimline Mechanism  
→ see page 3.27

## EasyFix front connector



656-0H66-380-00

 400 Pcs

- Drawer runner type
- Load capacity
- Minimum height per drawer required
- Drawer side thickness
- Wooden back panel thickness
- Wooden bottom panel thickness

full extension  
40 kg  
147mm  
14mm  
16mm  
16mm

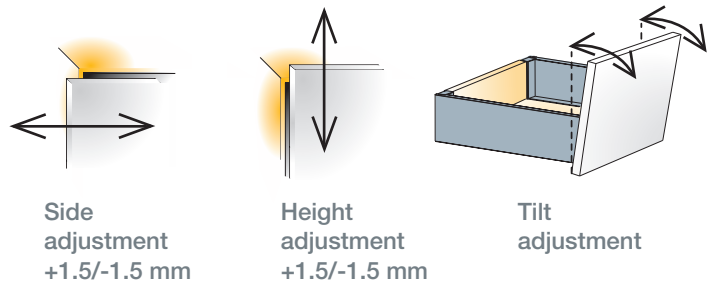

**i** Works with Tacto Push Opening Mechanism  
→ see page 3.27

For further explanation → see page 3.10

Installation dimensions and drillings

Drawer runner fixing positions

Front panel

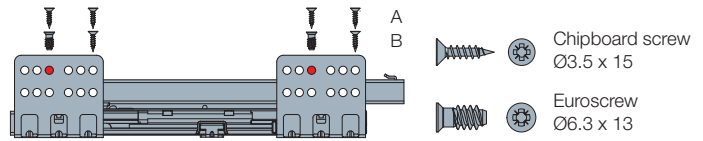
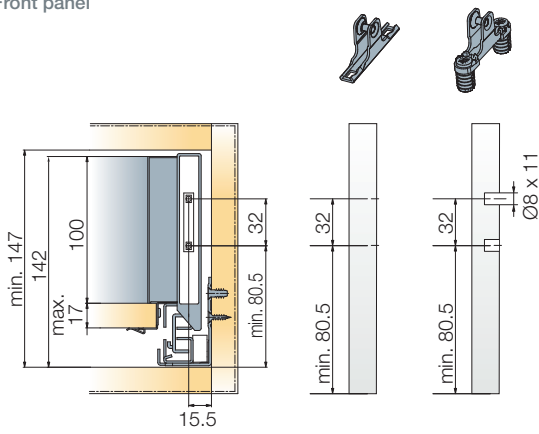

NL=270mm  
NL=300mm  
NL=350mm  
NL=400mm  
NL=450mm

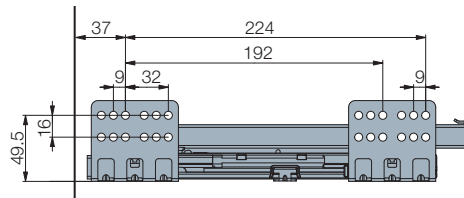

Back panel

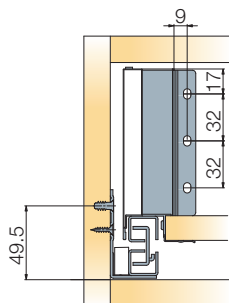

NL=500mm  
NL=550mm

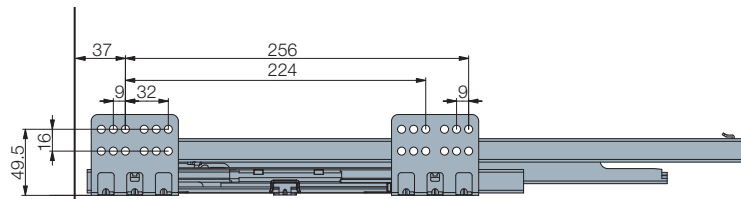

Assembly instructions, adjustments



A trial mounting is always recommended.  
For further information please contact your Titus Group representative.

# Tekform Slimline+ Drawer DW145

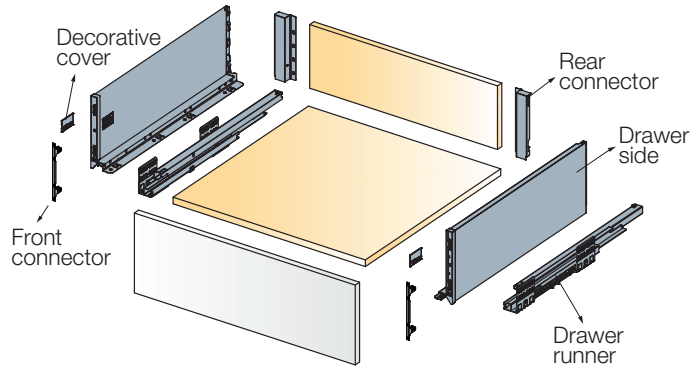
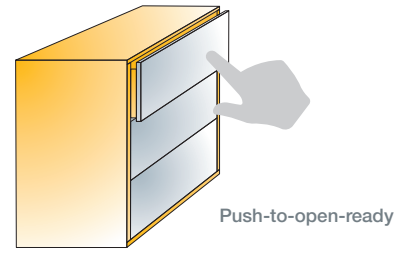

### Cutting dimensions details

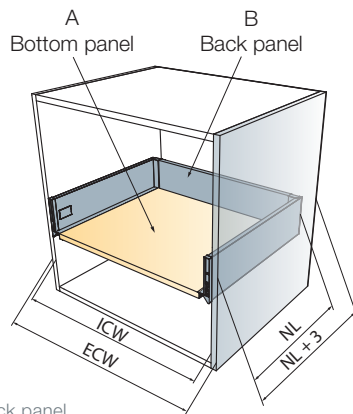

ECW: External cabinet width  
 ICW: Internal cabinet width  
 NL: Nominal length of drawer  
 L<sub>st</sub>: Length in case of steel back panel

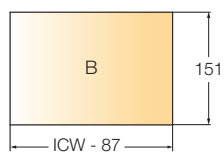
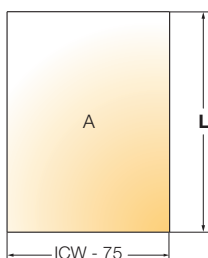

$L = NL - 10$   
 $L_{st} = NL - 20$   
 For further explanation → see page 3.8



Nominal length (mm)	with Screw-in front connector 		
		White	Anthracite
270	656-8367 →	150	185
300	656-8368 →	150	185
350	656-8369 →	150	185
400	656-8370 →	150	185
450	656-8371 →	150	185
500	656-8372 →	150	185
550	656-8373 →	150	185

### One set consists of

Drawer sides		2 pcs
Drawer runners		2 pcs
Front connectors		2 pcs
Rear connectors		2 pcs
Decorative covers		2 pcs
Mounting instructions		1 pc/4 sets

### Push opening



Tacto Slimline Mechanism  
 → see page 3.27

### EasyFix front connector



656-0H67-380-00

 400 Pcs

- Drawer runner type
- Load capacity
- Minimum height per drawer required
- Drawer side thickness
- Wooden back panel thickness
- Wooden bottom panel thickness

full extension  
40 kg  
198mm  
14mm  
16mm  
16mm

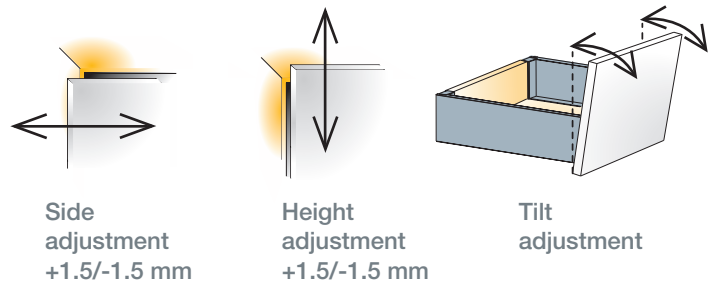

**i** Works with Tacto Push Opening Mechanism  
→ see page 3.27

For further explanation → see page 3.10

Installation dimensions and drillings

Drawer runner fixing positions

Front panel

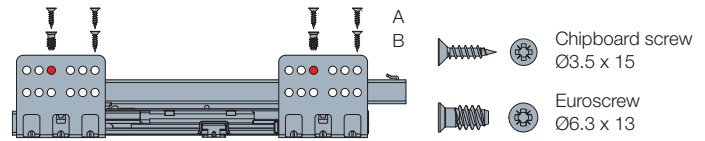
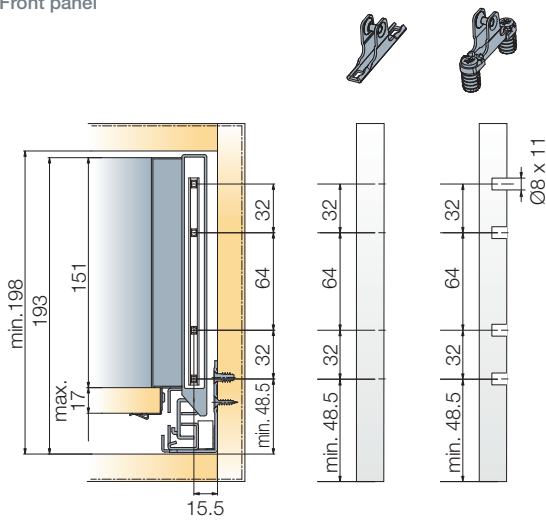

NL=270mm  
NL=300mm  
NL=350mm  
NL=400mm  
NL=450mm

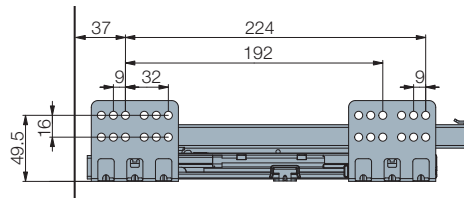

NL=500mm  
NL=550mm

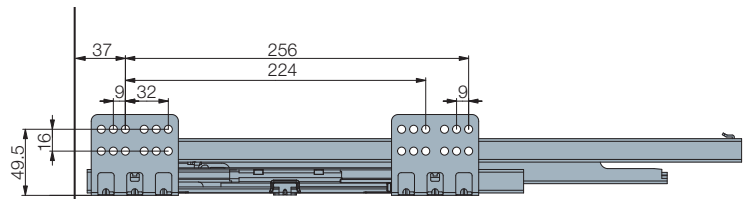

Back panel

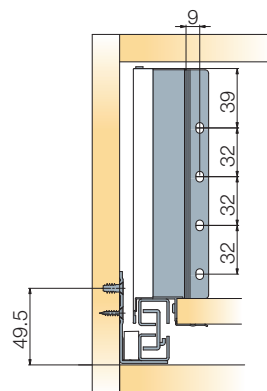

Assembly instructions, adjustments



A trial mounting is always recommended.  
For further information please contact your Titus Group representative.

# Tekform Slimline+ Drawer DW182

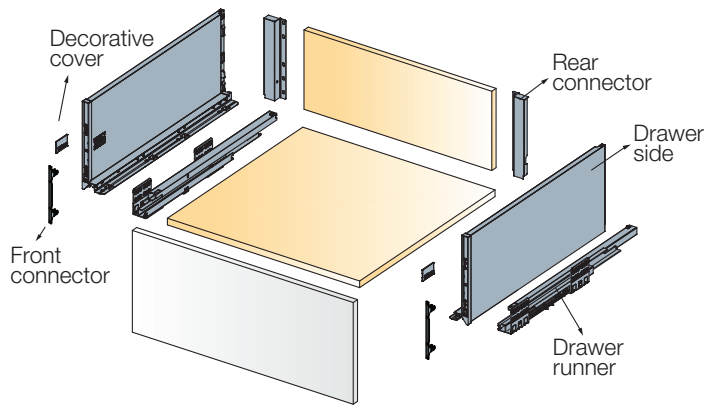
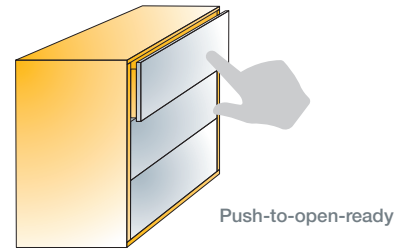

## Cutting dimensions details

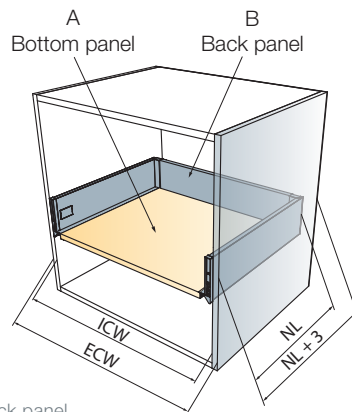

ECW: External cabinet width  
 ICW: Internal cabinet width  
 NL: Nominal length of drawer  
 L<sub>st</sub>: Length in case of steel back panel

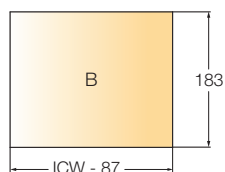
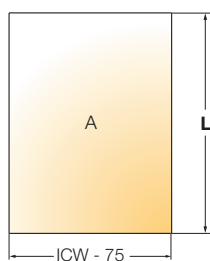

$L = NL - 10$   
 $L_{st} = NL - 20$   
 For further explanation → see page 3.8



Nominal length (mm)	with Screw-in front connector 		
		White	Anthracite
270	656-8374 →	150	185
300	656-8375 →	150	185
350	656-8376 →	150	185
400	656-8377 →	150	185
450	656-8378 →	150	185
500	656-8379 →	150	185
550	656-8380 →	150	185

## One set consists of

Drawer sides		2 pcs
Drawer runners		2 pcs
Front connectors		2 pcs
Rear connectors		2 pcs
Decorative covers		2 pcs
Mounting instructions		1 pc/4 sets

## Push opening



Tacto Slimline Mechanism  
 → see page 3.27

## EasyFix front connector



656-0H67-380-00

 400 Pcs

- Drawer runner type
- Load capacity
- Minimum height per drawer required
- Drawer side thickness
- Wooden back panel thickness
- Wooden bottom panel thickness

full extension  
40kg  
230mm  
14mm  
16mm  
16mm

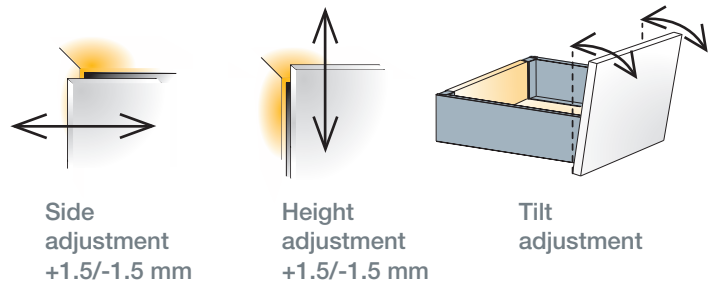

**i** Works with Tacto Push Opening Mechanism  
→ see page 3.27

For further explanation → see page 3.10

Installation dimensions and drillings

Drawer runner fixing positions

Front panel

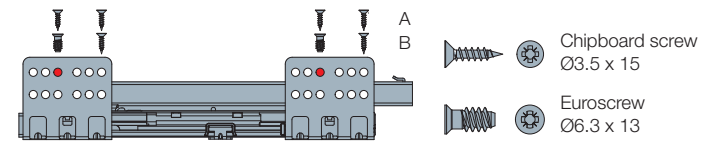
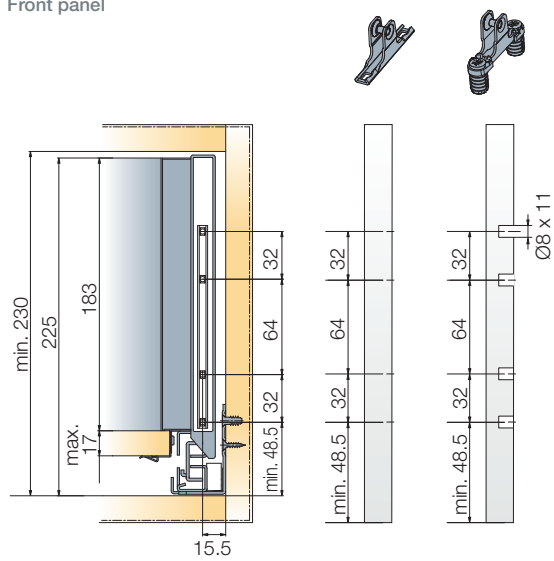

NL=270mm  
NL=300mm  
NL=350mm  
NL=400mm  
NL=450mm

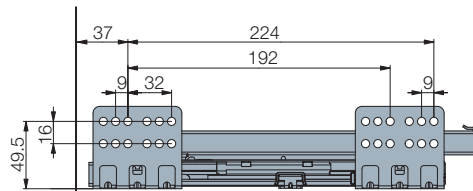

NL=500mm  
NL=550mm

Back panel

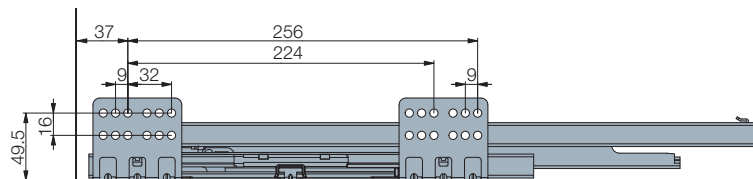
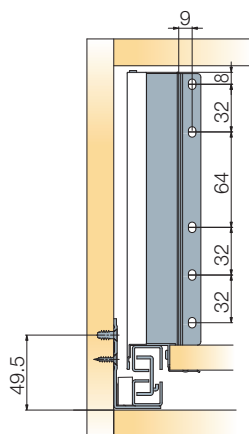

Assembly instructions, adjustments



A trial mounting is always recommended.  
For further information please contact your Titus Group representative.

# Inner Drawer Front for Tekform Slimline+ Drawer DW70

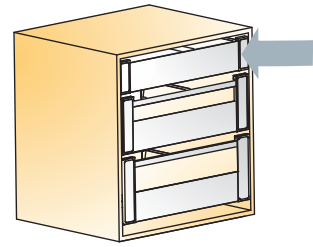

Front panel



Cutting dimension L = ICW-105  
ICW → see page 3.22



20 pcs

Made of aluminium

Front bracket



50 sets

Made of aluminium and plastic

External cabinet width	Item number	White	Antracite grey	
		600	656-8048 →	511
1200	656-8053 →	511	515	
		656-8334 →	350	385

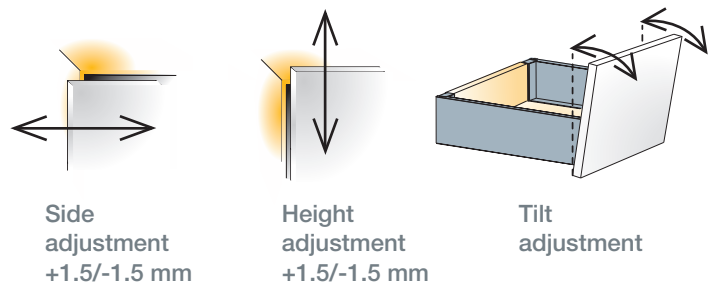
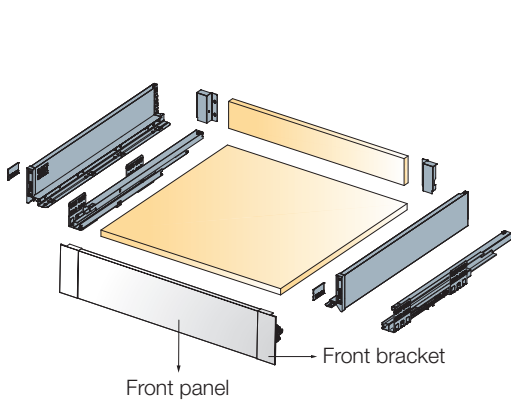

For further explanation → see page 3.10

Installation dimensions

Drawer runner fixing positions

Cutting dimensions details

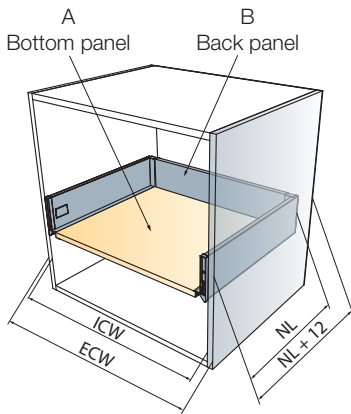

ECW: External cabinet width  
ICW: Internal cabinet width  
NL: Nominal length of drawer

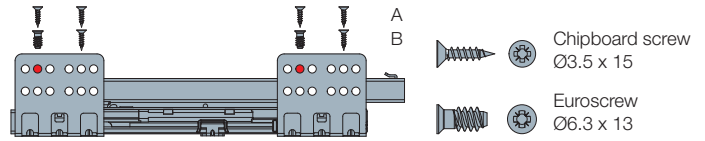

NL=270mm  
NL=300mm  
NL=350mm  
NL=400mm  
NL=450mm

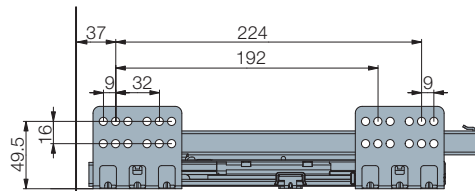

NL=500mm  
NL=550mm

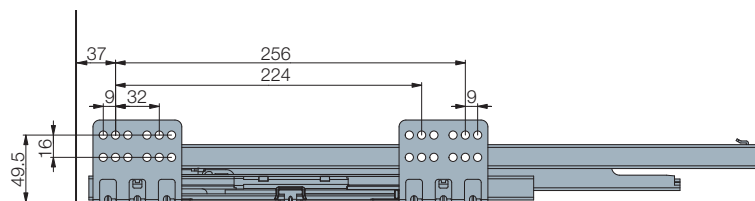

Assembly instructions, adjustments



# Inner Drawer Front for Tekform Slimline+ Drawer DW145 with Bar

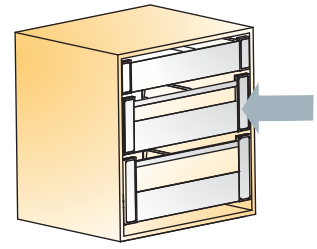

Front bar

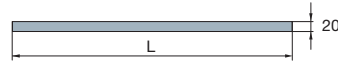

Cutting dimension L = ICW-94  
ICW → see page 3.24

 50 pcs

Made of aluminium

Front panel

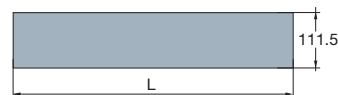

Cutting dimension L = ICW-105  
ICW → see page 3.24

 20 pcs

Made of aluminium

Front bracket



 20 pcs

Made of aluminium and plastic

External cabinet width	Item number	Color	
		White	Antracite grey
600	656-8126 →	511	515
1200	656-8132 →	511	515
600	656-8048 →	511	515
1200	656-8053 →	511	515
	656-8337 →	350	385

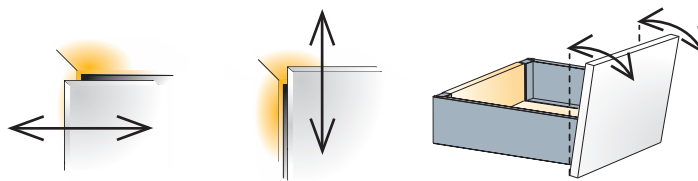
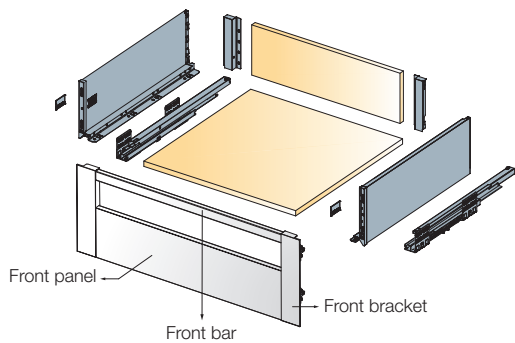

Side adjustment  
+1.5/-1.5 mm

Height adjustment  
+1.5/-1.5 mm

Tilt adjustment

For further explanation → see page 3.10

Installation dimensions

Drawer runner fixing positions

Cutting dimensions details

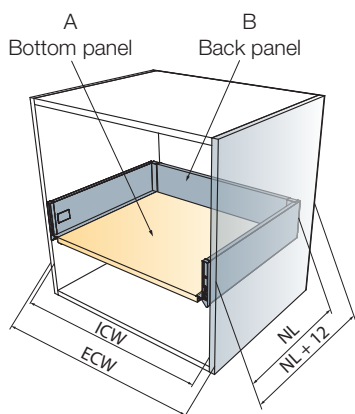

ECW: External cabinet width  
ICW: Internal cabinet width  
NL: Nominal length of drawer

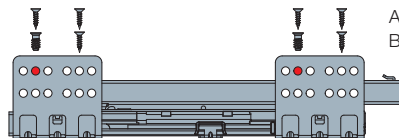

- Chipboard screw  
Ø3.5 x 15
- Euro screw  
Ø6.3 x 13

- NL=270mm
- NL=300mm
- NL=350mm
- NL=400mm
- NL=450mm

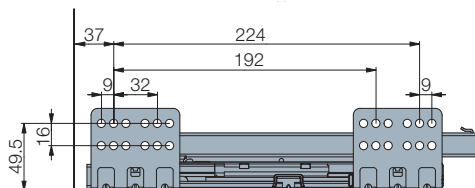

- NL=500mm
- NL=550mm

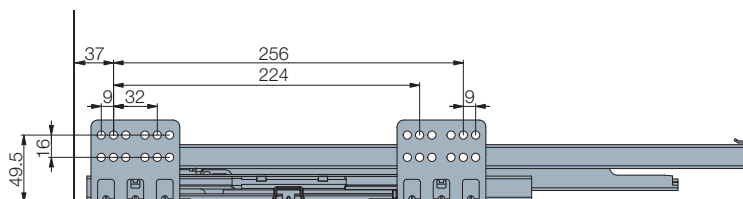

Assembly instructions, adjustments



# Inner Drawer Front for Tekform Slimline+ Drawer DW182 with Bar

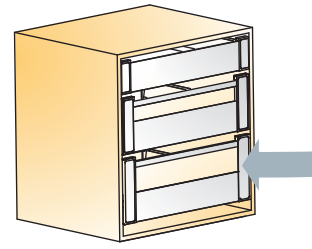

Front bar



Cutting dimension L = ICW-94  
ICW → see page 3.26

 50 pcs

Made of aluminium and plastic

Front panel

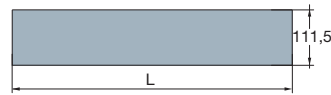

Cutting dimension L = ICW-105  
ICW → see page 3.26

 20 pcs

Made of aluminium

Front bracket



 20 sets

Made of aluminium and plastic

External cabinet width	Item number	Color	
		White	Antracite grey
600	656-8126 →	511	515
1200	656-8132 →	511	515
600	656-8048 →	511	515
1200	656-8053 →	511	515
	656-8341 →	350	385

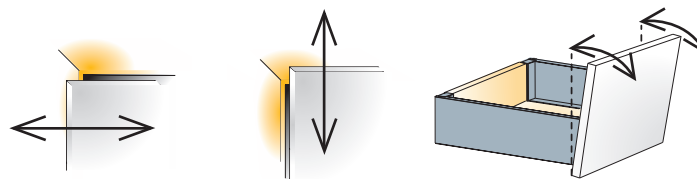
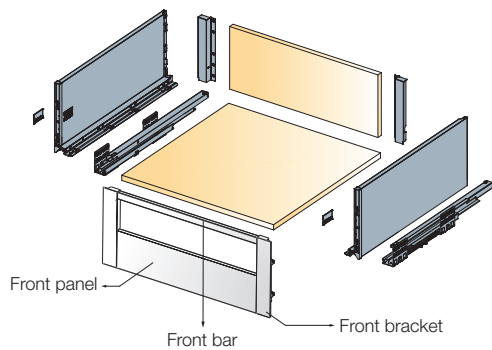

Side adjustment  
+1.5/-1.5 mm

Height adjustment  
+1.5/-1.5 mm

Tilt adjustment

For further explanation → see page 3.10

Installation dimensions

Drawer runner fixing positions

Cutting dimensions details

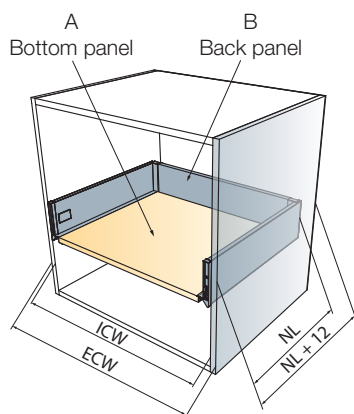

ECW: External cabinet width  
ICW: Internal cabinet width  
NL: Nominal length of drawer



- Chipboard screw  
Ø3.5 x 15
- Euro screw  
Ø6.3 x 13

- NL=270mm
- NL=300mm
- NL=350mm
- NL=400mm
- NL=450mm

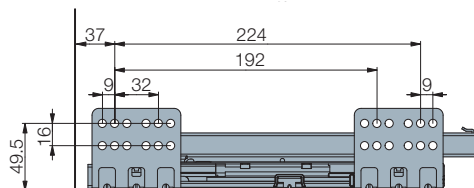

- NL=500mm
- NL=550mm

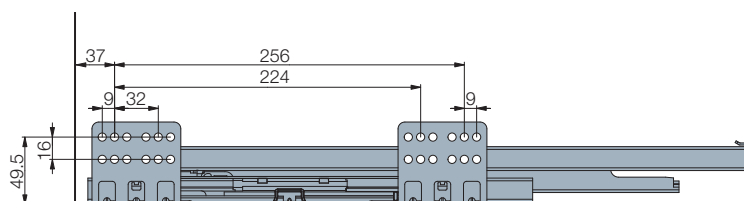

Assembly instructions, adjustments



# TouchControl Solutions

## Tacto 2.0

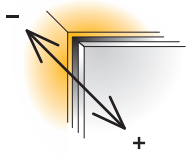

Front gap adjustment  
-1.5/+3.5mm



"Push-to-Open"

- Intuitive mounting
- One-for-all – One item fits all Slimline+ drawers from NL=300mm
- Easily adjustable push-to-open activation with only 1.5mm gap to operate
- Easy opening, reliable closing

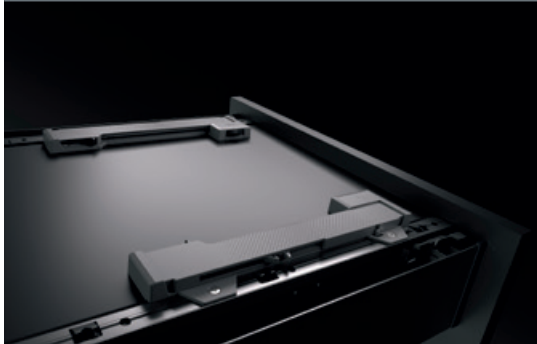

Tacto 2.0

Technical details

Item number for set

656-9220-383-K1



One set consists of

PushOpen Mechanism



2 pcs

Tacto Activator



2 pcs

Chipboard screws



4 pcs/set

Mounting instructions



1 pc/set

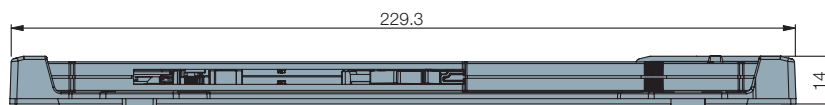
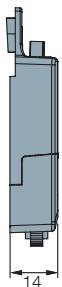
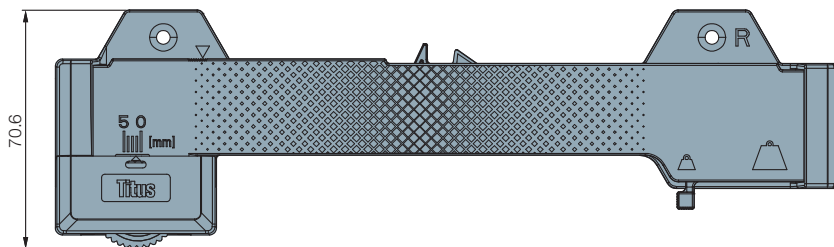

Assembly instructions, adjustments



 30 sets

Made of plastic

# Accessories

## Marking Jig

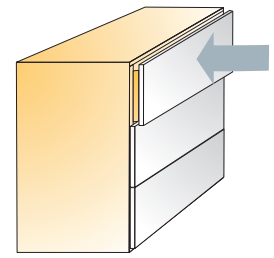

Tekform Slimline+ Drawer

Marking jig for Tekform Slimline+ drawer DW70 and DW100

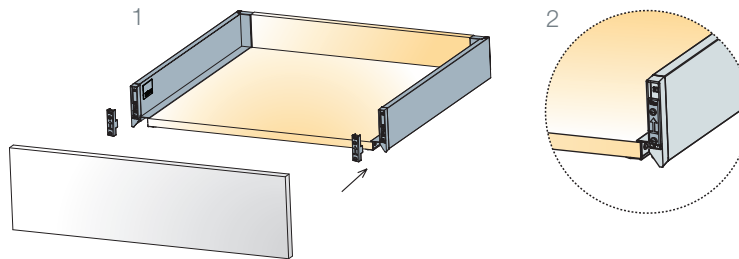

1 set

Made of plastic and steel

Item number

656-9339

Black

390

Marking jig for Tekform Slimline+ drawer DW145 and DW182

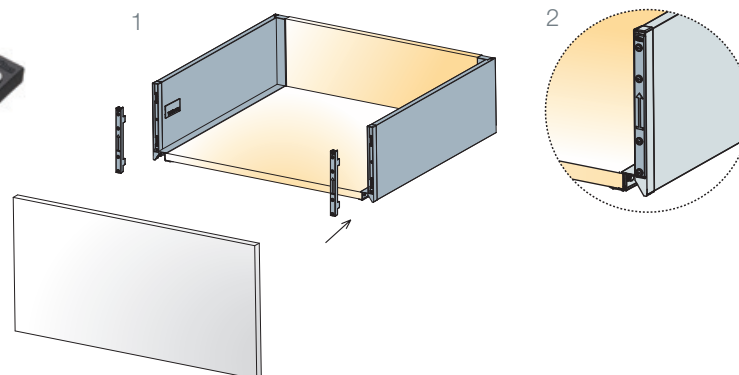

1 set

Made of plastic and steel





656-9340



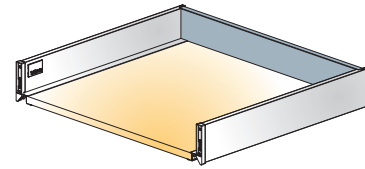

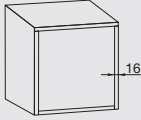
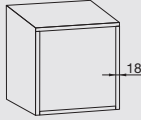
390

# Accessories

## Steel Back Panel

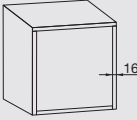
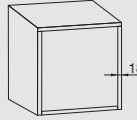

	ECW	Cabinet side thickness 16mm	Cabinet side thickness 18mm		
				White	Anthracite
	External cabinet width (mm)				
<b>Steel back panel DW70</b> 	300	655-7L01	655-7L30	150	185
	400	655-7L02	655-7L40	150	185
	500	655-7L03	655-7L50	150	185
	600	655-7L04	655-7L60	150	185
	700	655-7L05	655-7L70	150	185
	800	655-7L06	655-7L80	150	185
	900	655-7L07	655-7L90	150	185
	1000	655-7L08	655-7L10	150	185
	1200	655-7L09	655-7L12	150	185
	 10 pcs      Made of steel				
<b>Steel back panel DW100</b> 	300	655-7F01	655-7F30	150	185
	400	655-7F02	655-7F40	150	185
	500	655-7F03	655-7F50	150	185
	600	655-7F04	655-7F60	150	185
	700	655-7F05	655-7F70	150	185
	800	655-7F06	655-7F80	150	185
	900	655-7F07	655-7F90	150	185
	1000	655-7F08	655-7F10	150	185
	1200	655-7F09	655-7F12	150	185
	 10 pcs      Made of steel				

	ECW	Cabinet side thickness 16mm	Cabinet side thickness 18mm		
				White	Anthracite
External cabinet width (mm)					
<b>Steel back panel DW145</b> 	300	655-7M01	655-7M30	150	185
	400	655-7M02	655-7M40	150	185
	500	655-7M03	655-7M50	150	185
	600	655-7M04	655-7M60	150	185
	700	655-7M05	655-7M70	150	185
	800	655-7M06	655-7M80	150	185
	900	655-7M07	655-7M90	150	185
	1000	655-7M08	655-7M10	150	185
	1200	655-7M09	655-7M12	150	185
	 10 pcs      Made of steel				
<b>Steel back panel DW182</b> 	300	655-7H01	655-7H30	150	185
	400	655-7H02	655-7H40	150	185
	500	655-7H03	655-7H50	150	185
	600	655-7H04	655-7H60	150	185
	700	655-7H05	655-7H70	150	185
	800	655-7H06	655-7H80	150	185
	900	655-7H07	655-7H90	150	185
	1000	655-7H08	655-7H10	150	185
	1200	655-7H09	655-7H12	150	185
	 10 pcs      Made of steel				

# Tekform Slimline DW45

## Shallow Drawer

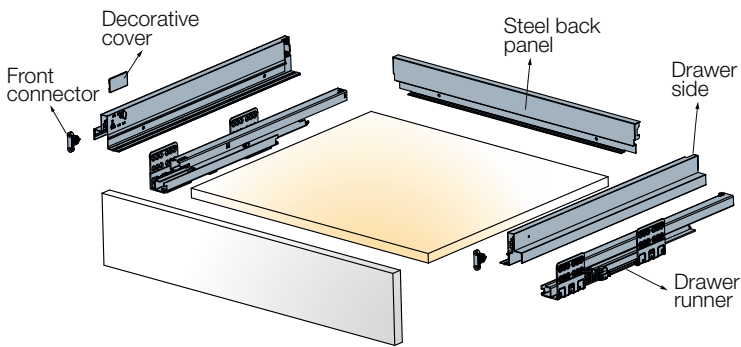
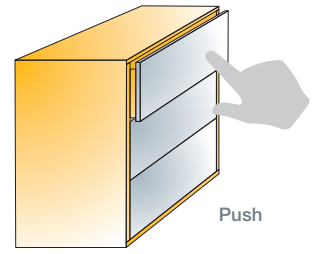



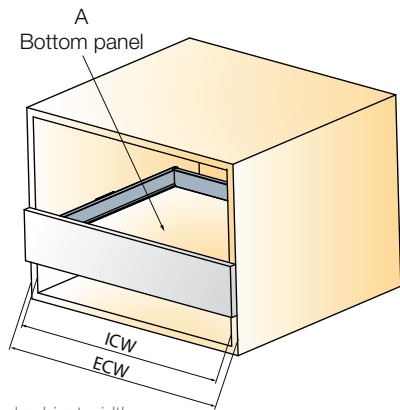

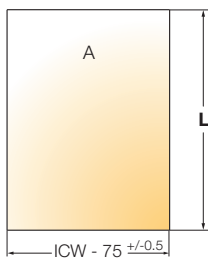

### Cutting dimensions details

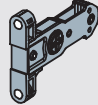

ECW: External cabinet width  
 ICW: Internal cabinet width  
 NL: Nominal length of drawer  
 L<sub>st</sub>: Length in case of steel back panel



L<sub>st</sub>: NL - 20  
 For further explanation  
 → see page 3.8

NL	with Screw-in front connector		
		White	Antracite
Nominal length (mm)		Item number for a set	
		450	655-8046
500	655-8047	150	185
To be ordered separately Steel back panel			
600*	655-7273	150	185
* cabinet side thickness 18mm			
One set consists of			
Drawer sides		2 pcs	
			
Drawer runners		2 pcs	
			
*Front connectors		2 pcs	
			
Covers		2 pcs	
		2 pcs	
Mounting instructions		1 pc/4 sets	
			

Screws are not included

- Drawer runner type
- Load capacity
- Minimum height space required
- Back panel
- Wooden bottom panel thickness

full extension  
40 kg  
76mm  
steel  
16mm

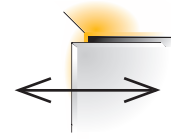

Side adjustment  
+1/-1mm

**i** Works with or without Tacto Mechanism

Installation dimensions

Minimum space required for the cabinet

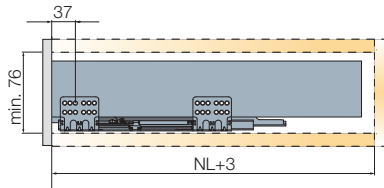

Drawer runner fixing positions

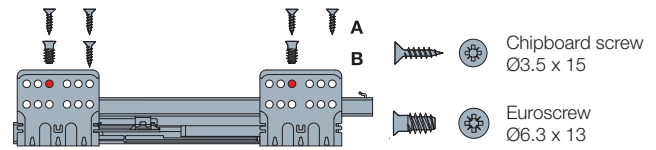

Drilling dimensions for the front panel

Screw-in attachment

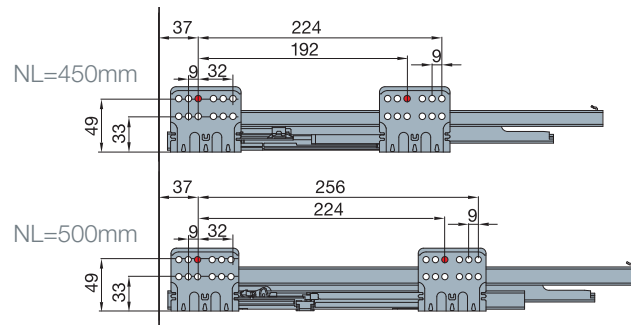
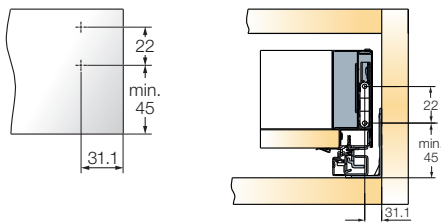

A trial mounting is always recommended.  
For further information please contact your Titus Group representative.



# Soft Closing Systems for Doors and Drawers

# Soft Closing Systems for Doors and Drawers



## Titus Damper Inside

- Smooth and even soft closing action on various door dimensions and weights
- Silent closing without a rebound
- Consistent performance in hot/cold environment

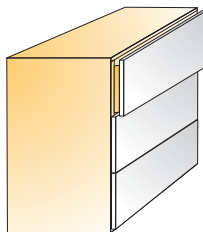

## Titussoft for drawers

- For metal box and roller runners

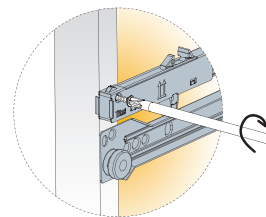

## Simple and intuitive mounting

- No pre-drilling required
- Non-handed
- User friendly

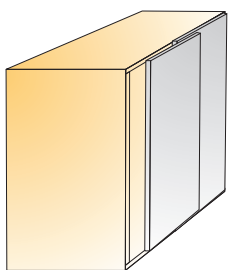

### Set 200s

- Reliable damping for bottom running sliding doors in two- and three-door wardrobes
- Quick, intuitive installation without the need for pre-drilling



### Comfortable door opening

- Low pull-open force
- Effortless opening



### Fully controllable damping curve

- Ability to fine tune performance to specific applications
- Precise definition of forces over the whole damping action

# Titusoft WD

## Soft Closing System for Wooden Drawer

For wooden drawer with roller runners

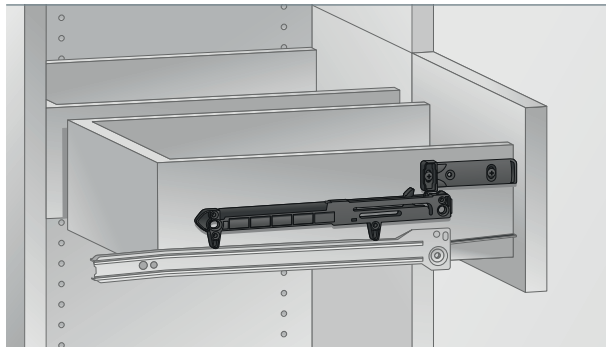
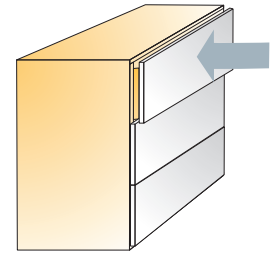

Technical details

Titusoft WD

Titusoft mechanism

Item number

973-0X35 →

Grey

White

380

Activator

973-4451 →

380

350



Titusoft mechanism

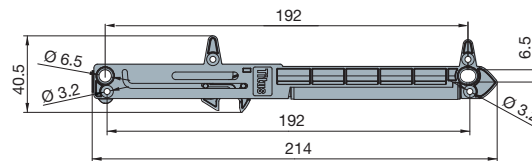

Bag of 1

973-0X35-380-K2  120 Bags

- 1 Titusoft mechanism
- 1 activator
- 2 screws Ø3.5mm x 20mm
- 2 screws Ø3.5mm x 12mm
- 1 mounting instruction sheet

Bag of 2

973-0X35-380-K1  80 Bags

- 2 Titusoft mechanisms
- 2 activators
- 4 screws Ø3.5mm x 20mm
- 4 screws Ø3.5mm x 12mm
- 1 mounting instruction sheet



Activator

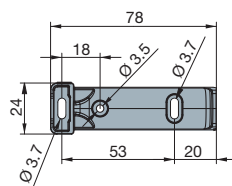

250 Pcs

200 Pcs (973-0X35 + activator)

Made of plastic

- Works with most roller runner drawer slides
- Easy, intuitive mounting
- Smooth, soft closing action independent of drawer hardware
- Optimal closing speed
- Non-handed design

### Capacity chart

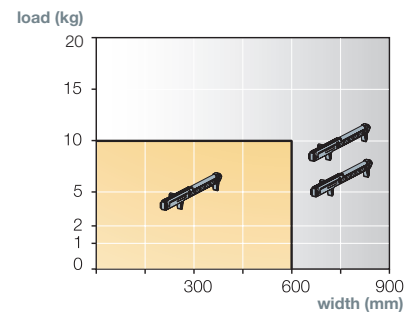

Mount 1 or 2 Titusoft mechanisms depending on drawer weight and width

### Mounting details

1.

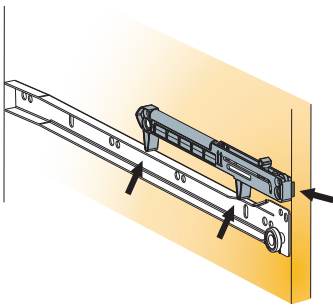

Position the Titusoft mechanism on the top of the drawer slide

2.

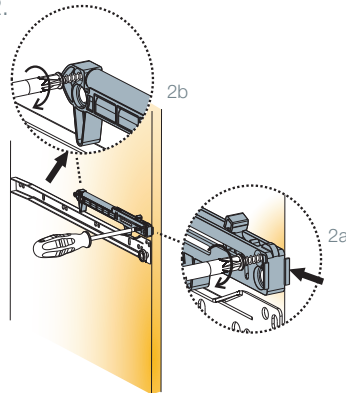

Fix with 2 screws L=20mm

3.

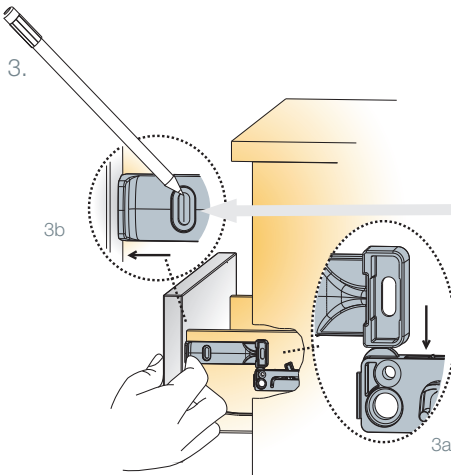

1. Rest the activator against the drawer front
2. Align the vertical position of the activator with the top of the Titusoft mechanism and mark the screw locations

4.

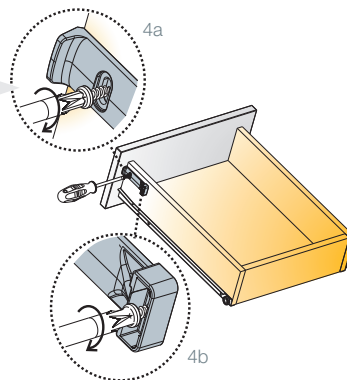

Fix with 2 screws L=12mm

A trial mounting is always recommended. Please contact Titus Group or your local distributor for further technical assistance.

# Titusoft MD

## Soft Closing System for Metal Box

For metal boxes

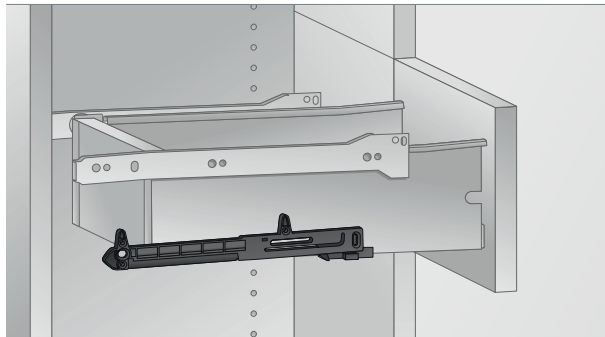
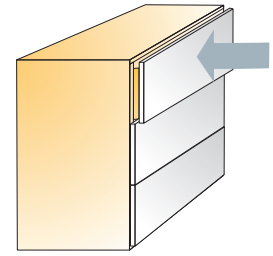

Titusoft MD



Item number	Grey	White	Light blue
Titusoft mechanism for factory mounting	380		
Titusoft mechanism for retrofit mounting	380		309
Activator		350	
Mounting jig			

**Bag of 1**  
**973-0X39-380-K2** 90 Bags  
 · 1 Titusoft mechanism  
 · 1 activator  
 · 1 mounting jig  
 · 4 screws  
 · 1 mounting instruction sheet

**Bag of 2**  
**973-0X39-380-K1** 60 Bags  
 · 2 Titusoft mechanisms  
 · 2 activators  
 · 1 mounting jig  
 · 8 screws  
 · 1 mounting instruction sheet

250 Pcs  
 150 Pcs (973-0X39 + activator)    Made of plastic

### Technical details

#### Retrofit mounting

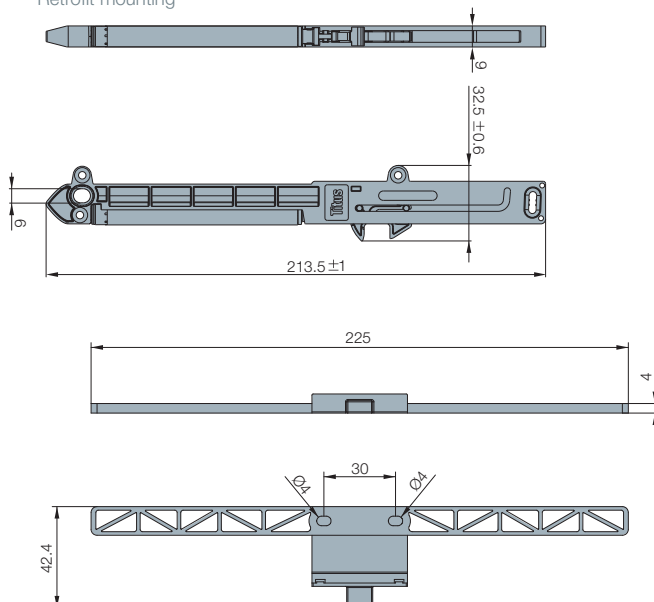

#### Factory mounting (system holes)

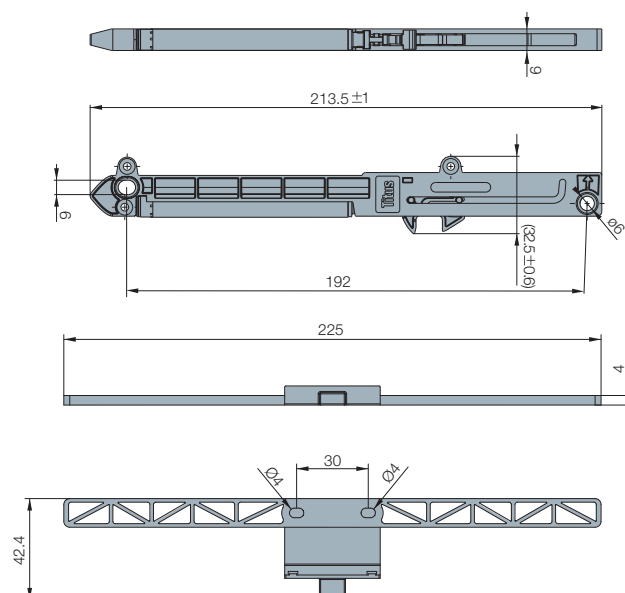

- One-for-all soft closing for single skin metal boxes
- Allows for easy factory mounting or retrofit application
- Intuitive positioning
- Preserve the life-time of the drawer

### Capacity chart

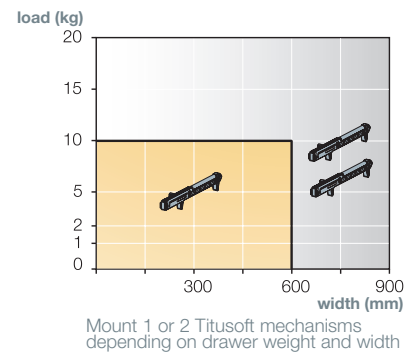

### Mounting details

#### Retrofit mounting

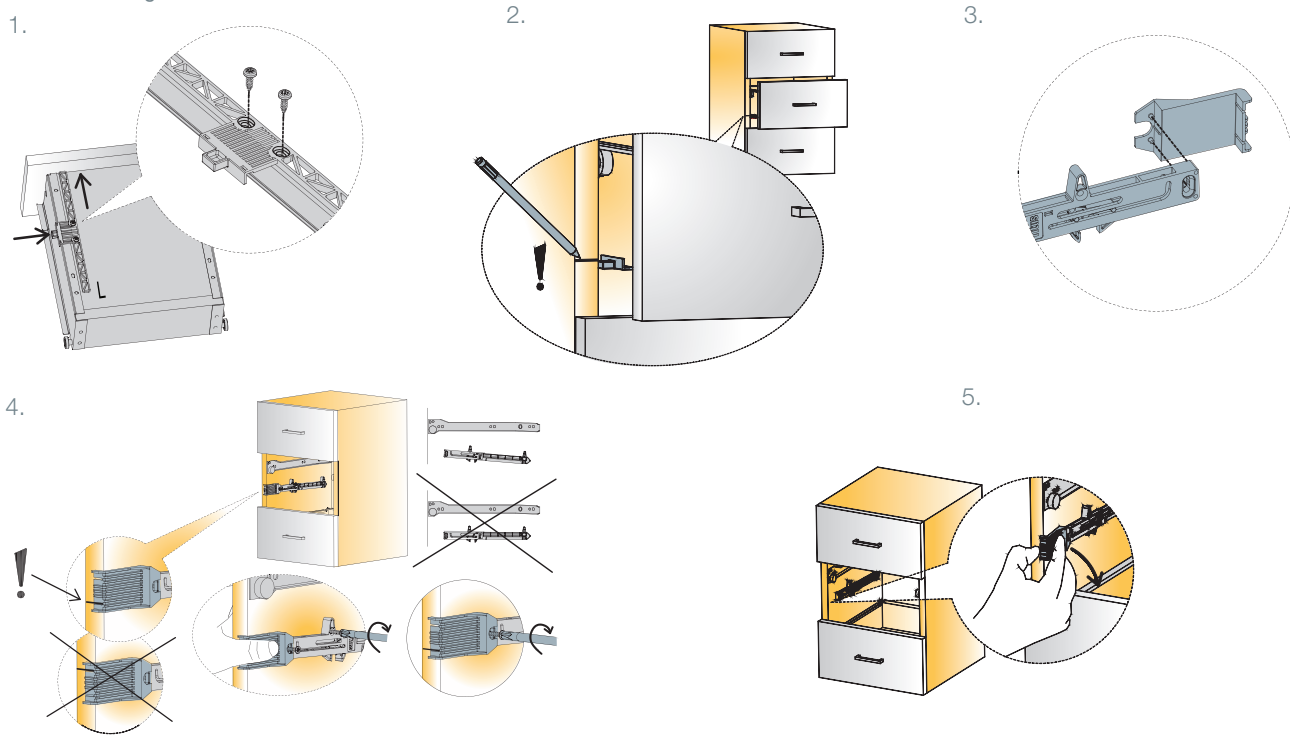

#### Factory mounting

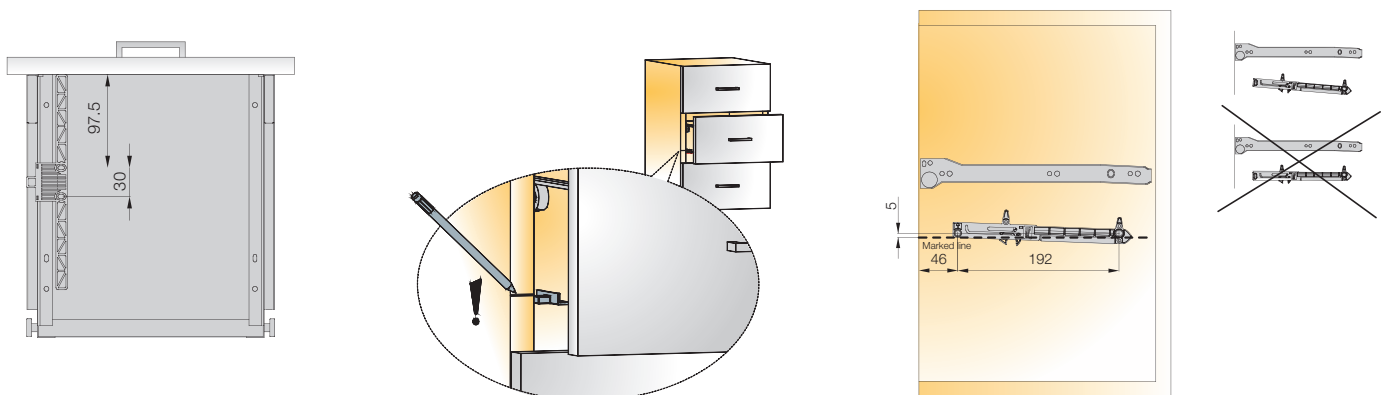

A trial mounting is always recommended. Please contact Titus Group or your local distributor for further technical assistance.

# Titusoft FF

## Soft Closing System for Face Frame Cabinets with Wooden Drawer

For wooden drawer  
with roller runners

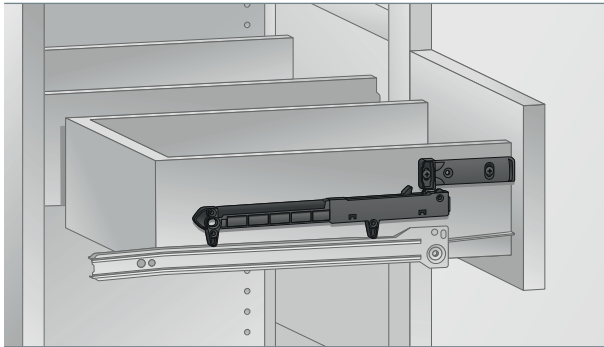
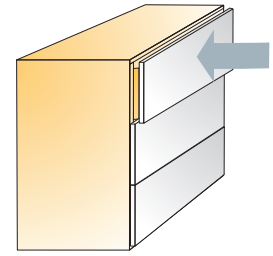

Technical details

Titusoft FF



Titusoft mechanism

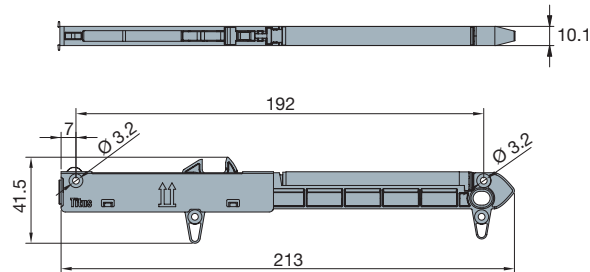

Activator

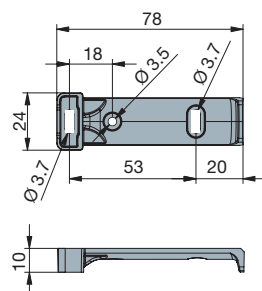

Item number

Titusoft  
mechanism

973-0M99 →

Grey

380

White

Activator

973-4451 →

380

350

### Bag of 1

**973-0M99-380-K1**  300 Bags

- 1 Titusoft mechanism
- 1 activator grey
- 2 screws Ø3.5mm x 25mm
- 2 screws Ø3.5mm x 12mm
- 1 mounting instruction sheet

 250 Pcs

Made of plastic

- Works with most roller runner drawer slides
- Easy, intuitive mounting
- Smooth, soft closing action independent of drawer hardware
- Non-handed design

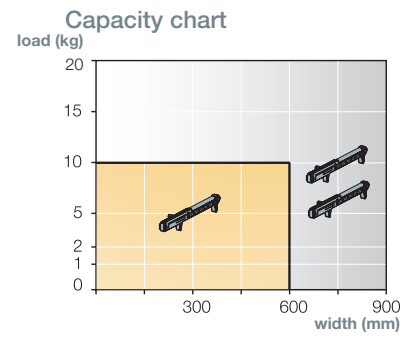

Mount 1 or 2 Titusoft mechanisms depending on drawer weight and width

**Mounting details**

1.

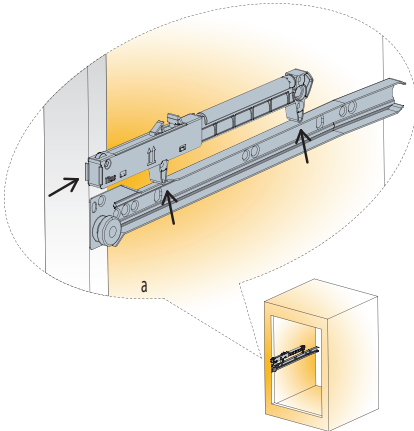

Position the Titusoft on the top of a drawer slide

2.

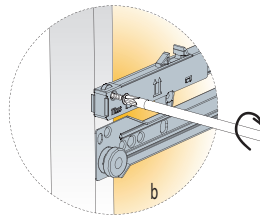

Screw the Titusoft mechanism to the face frame

3.

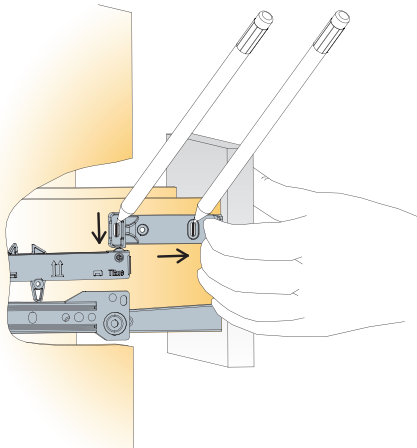

Align the activator with the top of the Titusoft mechanism and fix with two screws

4.

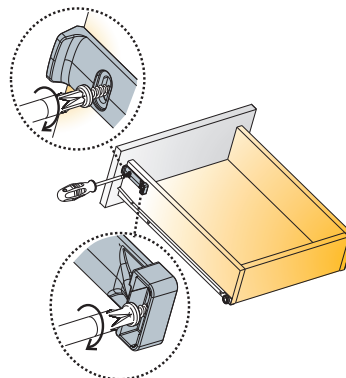

Fix with 2 (3) screws L=12mm

A trial mounting is always recommended. Please contact Titus Group or your local distributor for further technical assistance.

# Set 200s

## Sliding Door Mechanism

For bottom running sliding door systems

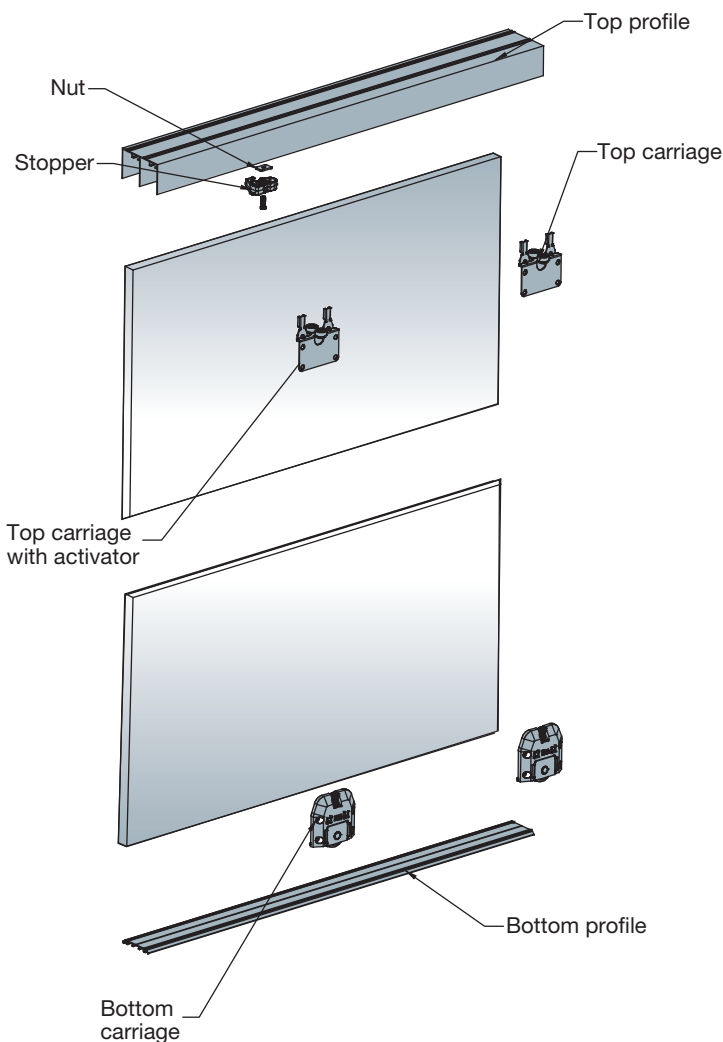
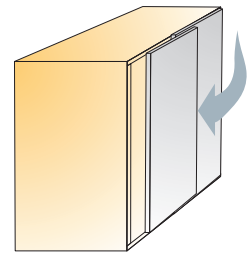

20 sets (610-9099-040-K1)

15 sets (610-9099-040-K2)

**i** Rails and accessories are not included in the set. Please order separately!

### Rails



### Accessories



Item number for set

Set for 2-doors

Set for 3-doors

610-9099-040

K1

K2

Set consists of the following components

Bottom carriages



4 pcs

6 pcs

Top carriage



2 pcs + 2 pcs

3 pcs + 3 pcs

Stopper



4 pcs

6 pcs + 1 pcs

Slot nut



4 pcs

8 pcs

Screw M4 x 16



4 pcs

8 pcs

Pan head screw



32 pcs

48 pcs

Self adhesive tape

5 pcs

5 pcs

Mounting instructions



1 pc

1 pc

- Door weight max. 50kg
- Door thickness 18-23mm
- Door material wood (chipboard, MDF, solid wood)

Door adjustment

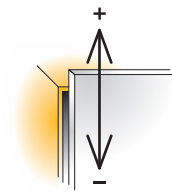

Height adjustment  
-0/+10mm

Mounting details

Technical details

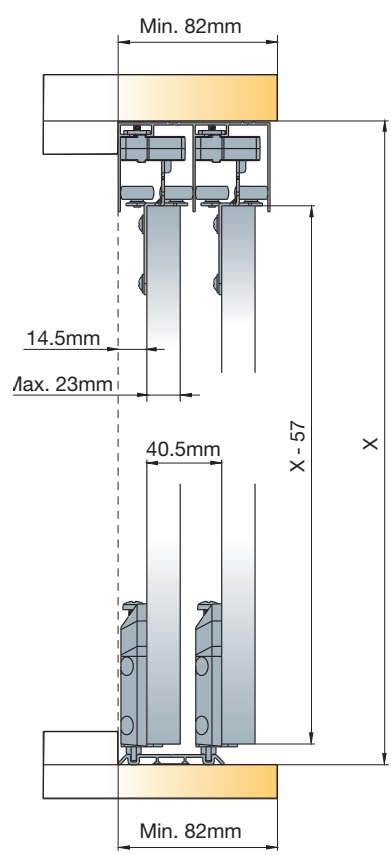

Top and bottom carriage drilling positions

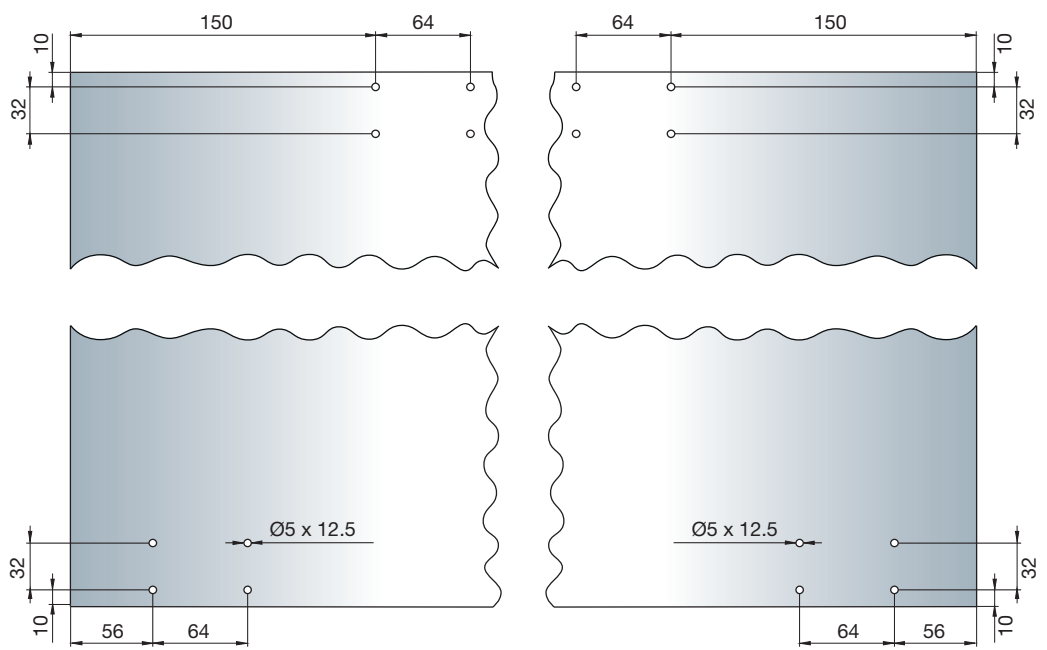

Height adjustment

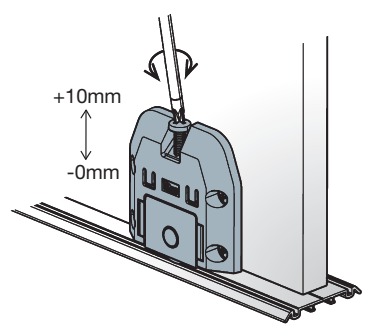

Bottom carriage is factory preset to the lowest value.







X = space available between top and bottom panel  
X - 57 = door height

# Rails

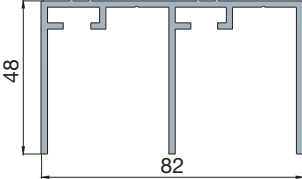
## For Set 200

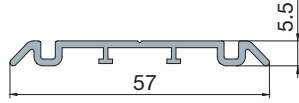

Screws for top rail are not supplied and depend on the application (cabinet, built-in cabinet).  
Bottom rail is fixed with self-adhesive tape.  
Rail is pre-drilled and ready to install.

		Rail length	Item number
<p>Top rail</p>  <p>Technical details</p> 	2000	610-9103-070-K1	
	2400	610-9106-070-K1	
	3000	610-9109-070-K1	
		<i>*other lengths upon special request</i>	
<b>Set consists of:</b>			
<p>Bottom rail</p>  <p>Technical details</p> 	<p>Top rail</p> 	1 pc	
	<p>Bottom rail</p> 	1 pc	
 5 sets			

# Accessories

## Slidix Soft Closing Systems

	Item number for set	Set for 2-doors	Set for 3-doors
<p>Slidix Solo 50</p> 	<p>610-9196-380 →</p>	K2	K3
	Set consists of		
	<p>Slidix Solo 50</p> 	4 pcs	6 pcs
	<p>Slidix Centro 50</p> 		1 pcs
	<p>Nuts for slidix</p> 	4 pcs	6 pcs
	<p>Screws for slidix</p> 	4 pcs	6 pcs
<p>Slidix Centro 50 for middle door</p> 			
 20 sets (610-9196-380-K2)			
 26 sets (610-9196-380-K3)			



# Titus Group

## **Products. People. Relationships.**

We are proud to support furniture manufacturers, designers, distributors and OEM partners worldwide with solutions that are precise, reliable and simple to work with.

From our engineering centres to your production line, and from first contact to long-term support, we're here to help you build better – with less complexity, more clarity, and total confidence.

# Titus Group

Titus Group designs and manufactures precision-engineered components that simplify furniture assembly, improve functionality, and ensure long-term reliability. Our core solutions – including connectors, hinges, dampers, soft-close systems, and drawer technologies – are trusted by manufacturers across a wide range of industries, from furniture and kitchens to home appliances and beyond.

With engineering, manufacturing, and customer support facilities across **Europe, Asia, North America, and Australasia**, we combine global consistency with local responsiveness.

Our vertically integrated operations support fast development, reliable delivery, and consistently high quality across markets.

For decades, we have been driven by a clear principle: **Engineered for Purpose**. This defines how we design, how we manufacture, and how we collaborate with our partners. Through **engineering simplicity**, we help our customers work more efficiently, reduce complexity, and bring better products to market – with confidence and consistency.

---

## 1973

Titus established

---

---

## 1975

Revolution in particleboard panel processing productivity

---

---

## 1977

Titus launches concealed cabinet connector

---

---

## 1980

Titus USA office and manufacturing established

---

---

## 1990

Launch of innovative Quickfit technology

---

---

## 2005

Titusonic ultrasound fastening technology introduced

---

---

## 2006

Merger with Lama d.d.  
Launch of Glissando

---

---

## 2007

Titus becomes Titus+  
Specialist in precision components engineering

---

---

## 2009

Damper development and engineering

---

---

## 2014

Acquisition of Tekform, Australia

---

---

## 2017

Launch of T-type full hinge programme

---

---

## 2019

Launch of TeraBlack product range

---

---

## 2020

Acquisition of Simon Kinetics, Germany

---

---

## 2022

Acquisition of Titus Precision, USA

---

---

## 2023

Launch of T-type PressTo toolless mounting

---

## Our Vision

To be the world's best in engineering for precision components.

## Our Mission

To provide manufacturers with component solutions that improve their competitiveness.

## Our Principles

- Gain total knowledge of our customers and their markets.
- Focus on identifying and creating high-volume component niches.
- Meet our customers' expectations with global consistency.
- Build long-term associations with customers, suppliers, colleagues and shareholders.
- Invest in the abilities of individuals at every level.
- Continuously enhance input efficiency and sustainability.
- Provide equal opportunities to all.

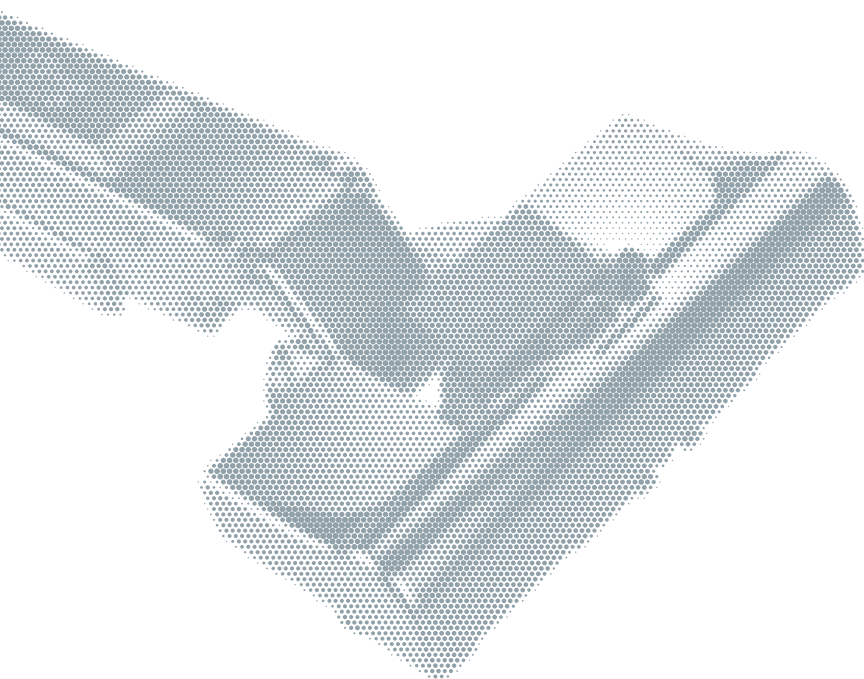
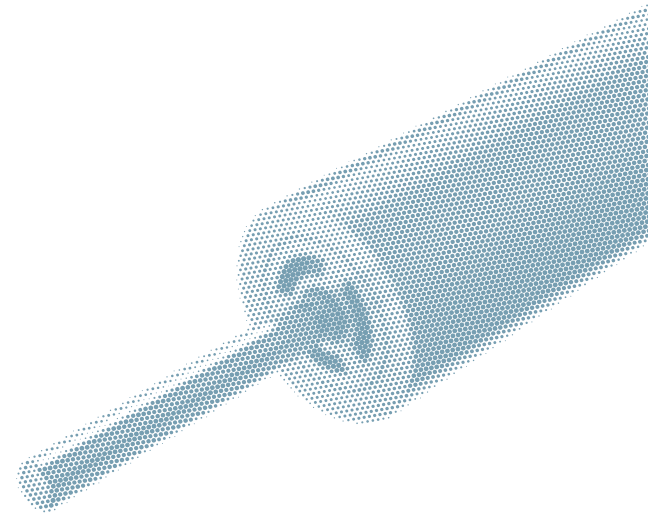

# Product Groups

## Cabinet Hardware

Cabinet connectors, concealed hinges, soft-close systems, kitchen drawers and accessories, RV hardware



---

## Damping and Kinetics

Hydraulic dampers and Slidix soft-close systems for custom applications in home equipment



---

## Titus Technologies

Automated assembly systems  
Die casting technologies  
Titusonic – Ultrasound fastening  
FastFit insertion technology



# Totally Integrated Engineering

At Titus, **Totally Integrated Engineering** means bringing together product design, proprietary manufacturing technologies, and fully controlled in-house operations into a single, seamless process. This integrated approach allows us to develop, produce, and deliver precision-engineered components that are consistent, reliable, and tailored to purpose.

It's not just about what we do – it's how we do it. By maintaining control across the entire development and production chain, we deliver measurable advantages to our customers: consistent product quality, faster time to market, and meaningful product benefits that lower total installed cost.

**Our approach is guided by a set of core principles that define who we are and how we operate:**

## Manufacturing Operations

Fully controlled in-house operations  
A wide range of proprietary technologies and services enabling high-volume production of precision components with consistency and speed.

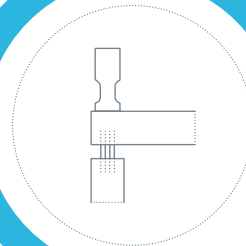

## Manufacturing Technologies

Process optimisation through proprietary innovation  
Advanced manufacturing technologies that increase productivity, ensure repeatable quality, and support scalable growth.

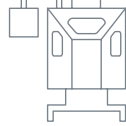

## Precision Components

Engineered for consistency, reliability, and purpose  
Precision components designed to meet exacting performance standards – delivering built-in value from concept to final assembly.

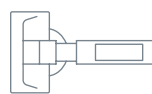

## Product Design

Component design for repeatable excellence  
Unique components engineered for consistent quality, functional simplicity, and efficient integration into high-volume systems.

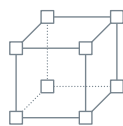

# Engineered for Purpose

At **Titus Group**, engineering is never about excess. It's about intention. Every product, every feature, every process is developed with a clear purpose: to solve a real problem and deliver lasting value.

**Engineered for Purpose** is more than a slogan – it's our mindset.

It defines how we innovate, how we manufacture, and how we collaborate.

## Focused on what matters

We don't follow trends for the sake of it. We listen to our customers, understand their needs, and deliver what works. Our solutions are built to perform in the real world – in real kitchens, real bedrooms, real production lines.

This focus allows us to eliminate unnecessary complexity and design components that are not only technically advanced, but also intuitive and dependable.

## A solution provider, not just a manufacturer

We go beyond hardware. We work alongside our customers to co-create solutions that integrate seamlessly into their production processes and business models. From idea to implementation, we ensure speed, precision, and consistency — globally.

Whether it's:

- Developing smart connectors that tolerate drilling inaccuracies,
- Designing hinges that make tall doors align effortlessly, or
- Engineering soft-close systems that deliver just the right resistance,

... we always have a purpose in mind: to make furniture manufacturing easier, faster, and more competitive.

## Built on experience. Proven by performance.

We apply decades of engineering knowledge across industries and markets, ensuring that our solutions are both reliable and scalable. Every new product is tested, refined, and validated to ensure that it performs consistently – across regions, materials, and applications.

**Because to us, engineered for purpose means engineered for you.**

# Titus Group Companies Worldwide

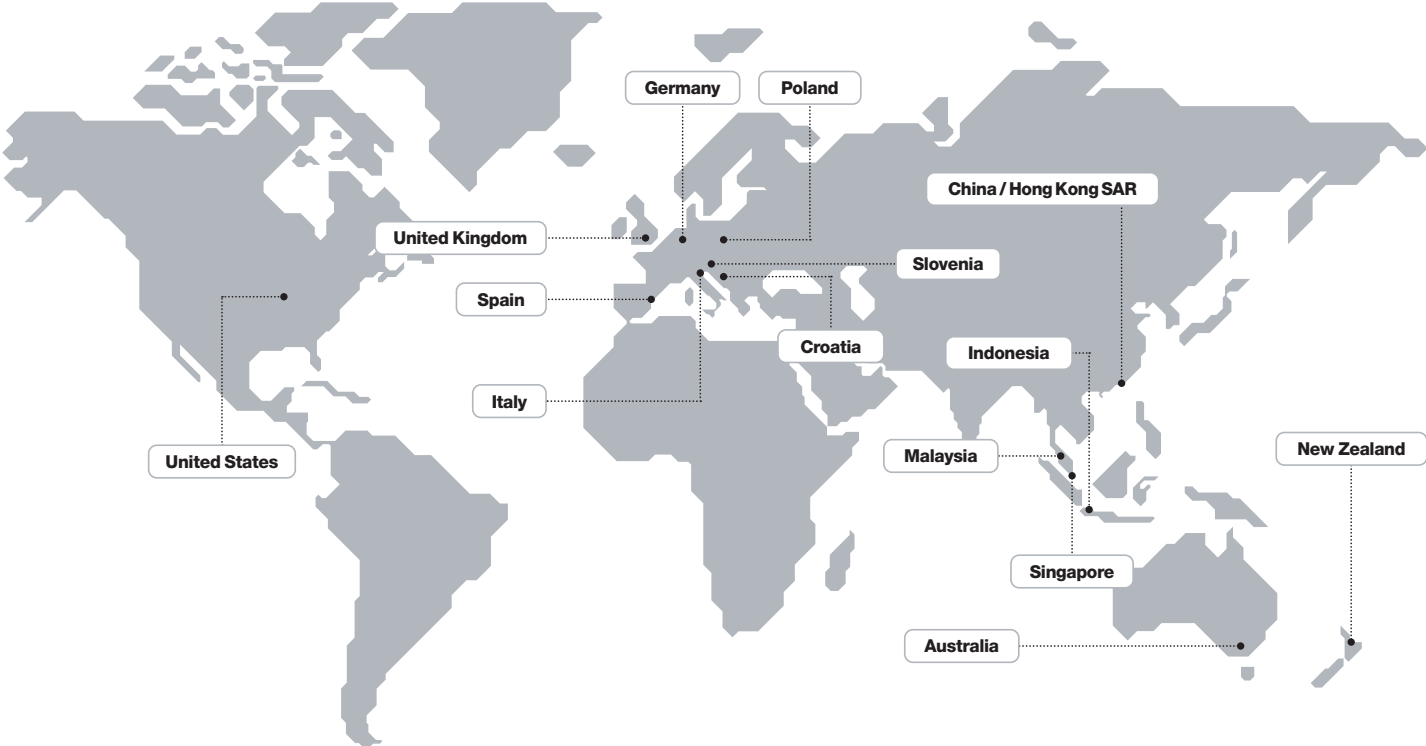

This map shows Titus Group companies only. For distribution partners, visit [titusplus.com](http://titusplus.com).

## **Engineered for Purpose**

Titus is committed to providing its customers with products and services that improve their competitiveness, while reducing manufacturing and assembly costs.



# Index

Item number	Page
00021	1.17
00022	1.17
00033	1.85
00180	1.10
00435	1.55
00436	1.55
01029	1.44
01373	1.84
01822	1.74
01823	1.74
01825	1.74
01828	1.74
01829	1.74
01837	1.74
01838	1.74
01843	1.74
01852	1.74
01910	1.76
01911	1.76
01912	1.75
01916	1.76
01924	1.73
01927	1.73
02075	1.12
02077	1.12
02107	1.18
02110	1.80
02111	1.80
02120	1.18
02130	1.18
02133	1.80
02139	1.18
02141	1.18
02144	1.18
02154	1.78
02161	1.17
02190	1.17
02193	1.17
02254	1.78
02523	1.84
02549	1.83
02558	1.81
02559	1.81
02560	1.81
02569	1.83
02570	1.83
02571	1.83
02574	1.83
02575	1.82
02578	1.84
02579	1.82
02582	1.82
02630	1.81

Item number	Page
02634	1.84
02642	1.82
02648	1.83
02653	1.83
02663	1.82
02666	1.83
02669	1.82
02671	1.82
02672	1.82
02699	1.83
02706	1.83
02710	1.84
03090	1.14
03118	1.14
03150	1.14
03168	1.14
03180	1.14
03181	1.14
05010	1.39
05050	1.32
05052	1.32
05072	1.36
05073	1.36
05078	1.36
05079	1.36
05087	1.36
05147	1.32
05270	1.32
05282	1.38
05314	1.31
05366	1.31
05380	1.37
05388	1.31
05409	1.68
05410	1.68
05414	1.33
05453	1.31
05474	1.31
05503	1.31
05552	1.32
05554	1.32
05556	1.32
05563	1.32
05574	1.43
05575	1.43
05576	1.43
05578	1.43
05579	1.43
05580	1.43
05592	1.37
05608	1.39
05609	1.39
05610	1.39

Item number	Page
05611	1.39
05751	1.37
05752	1.37
05753	1.37
05757	1.37
05772	1.37
05774	1.37
05775	1.37
05778	1.37
05857	1.37
05858	1.37
05859	1.37
05860	1.38
05917	1.69
05929	1.37
05960	1.69
05971	1.69
06073	1.12
06308	1.85
06309	1.85
06310	1.85
06343	1.55
06348	1.55
06381	1.54
06383	1.54
06385	1.54
06387	1.54
06395	1.52
06397	1.52
06401	1.48, 1.60
06402	1.48, 1.60
06403	1.48, 1.60
06405	1.48, 1.60
06406	1.48, 1.60
06408	1.47
06410	1.47
06411	1.50, 1.62
06412	1.50, 1.62
06413	1.49, 1.61
06414	1.49, 1.61
06415	1.50, 1.62
06416	1.49, 1.61
06431	1.51
06433	1.51
06435	1.51
06437	1.51
06439	1.52
06441	1.52
06443	1.52
06445	1.52
06447	1.51
06449	1.51
06451	1.51

Item number	Page
06453	1.51
06455	1.52
06457	1.52
06459	1.52
06461	1.52
06464	1.53
06465	1.53
06470	1.53
06471	1.53
06472	1.53
06473	1.53
06479	1.47
06495	1.48, 1.60
06576	1.59
06596	1.65
06619	1.64
06620	1.64
06621	1.64
06622	1.64
06627	1.59
06629	1.59
06802	1.16
06803	1.16
06806	1.16
06839	1.16
06973	1.63
06975	1.63
06977	1.63
06979	1.63
09330	1.41
09332	1.40
09333	1.41
09334	1.41
09335	1.40
09336	1.40
09337	1.41
09406	1.42
09423	1.34
09424	1.34
09435	1.34
09443	1.34
09456	1.34
09491	1.42
09583	1.34
09588	1.34
09592	1.34
09594	1.34
09597	1.35
09631	1.42
09651	1.30
09652	1.30
09690	1.40
09692	1.40

# Index

Item number	Page	Item number	Page	Item number	Page	Item number	Page
09695	1.40	244-0260-050	2.124	244-0M29-650	2.164	248-0431-050	2.109
09699	1.40	244-0261-050	2.124	244-0M33-650	2.126	248-0433-050	2.109
241-0043-650	2.167	244-0262-050	2.124	244-0P24-050	2.164	248-0482-050	2.99
241-0050-650	2.167	244-0263-050	2.124	244-0P25-050	2.164	248-0487-050	2.99
242-0824-650	2.95	244-0264-050	2.124	244-0P26-050	2.126	248-0532-050	2.99
242-0885-650	2.93	244-0265-050	2.124	244-0P27-050	2.126	248-0533-050	2.99
242-0886-650	2.93	244-0266-050	2.124	244-0P28-650	2.139, 2.149	248-0534-050	2.99
242-0924-650	2.133	244-0270-050	2.124	244-0P29-650	2.126	248-0535-050	2.99
242-0967-054	2.131	244-0271-050	2.124	244-0P41-650	2.164	248-0536-050	2.99
242-0968-054	2.131	244-0272-050	2.124	244-0S65-050	2.164	248-0537-050	2.99
242-0970-054	2.87	244-0342-050	2.124	244-0S66-050	2.164	248-0545-050	2.99
242-0971-054	2.87	244-0343-050	2.124	244-0S67-050	2.164	248-0547-050	2.99
242-0973-054	2.131	244-0344-050	2.124	244-0S68-050	2.164	248-0665-050	2.107
242-0974-054	2.131	244-0561-050	2.126	244-0T14-650	2.164	248-0675-050	2.107
242-0976-054	2.87	244-0562-050	2.126	244-0T28-050	2.164	248-0742-050	2.111
242-0977-054	2.87	244-0565-050	2.126	244-0T40-050	2.164	248-0745-050	2.111
242-0979-054	2.131	244-0566-050	2.126	244-0V19-050	2.126	248-0AW6-050	2.115
242-0980-054	2.131	244-0567-050	2.126	244-0V50-050	2.166	248-0AW8-050	2.115
242-0997-054	2.87	244-0568-050	2.126	244-0V64-050	2.164	248-0AW9-050	2.115
242-0998-054	2.87	244-0655-050	2.169	244-0Z26-050	2.126	248-0G49-050	2.141
242-0C27-650	2.135	244-0810-650	2.139, 2.149	244-0Z51-050	2.126	248-0G50-050	2.141
242-0D14-650	2.135	244-0813-650	2.149	244-0Z63-050	2.126	248-0G51-050	2.141
242-0G76-650	2.95	244-0846-050	2.169	244-1136-050	2.126	248-0G52-050	2.143
242-0H17-650	2.95	244-0848-650	2.167	244-1137-050	2.126	248-0G53-050	2.149
242-0H34-650	2.133	244-0866-050	2.164	244-1138-050	2.126	248-0G54-050	2.141
242-0H48-650	2.137	244-0867-050	2.164	244-1139-050	2.126	248-0G55-050	2.141
242-0H49-650	2.137	244-0907-650	2.167	244-1228-050	2.126	248-0G56-050	2.141
242-0P81-650	2.95	244-0914-650	2.164	244-1229-050	2.126	248-0G57-050	2.143
242-0W48-650	2.91	244-0929-050	2.164	244-1233-05	2.126	248-0G58-050	2.149
242-0W71-650	2.89	244-0930-050	2.164	244-1234-050	2.126	248-0G79-050	2.141
242-0W72-650	2.89	244-0965-050	2.164	244-1645-050	2.126	248-0G80-050	2.141
242-0Y45-650	2.97	244-0B12-650	2.164	244-3016-650	2.126	248-0G81-050	2.141
242-0Y46-650	2.97	244-0C32-650	2.139, 2.149	244-3651-650	2.126	248-0G82-050	2.143
242-0Y48-650	2.139	244-0D46-650	2.167	244-3653-650	2.128	248-0G83-050	2.149
242-0Y49-650	2.139	244-0D47-650	2.167	244-3654-650	2.128	248-0K10-050	2.169
244-0062-650	2.164	244-0D99-650	2.167	244-3655-650	2.128	248-0K40-050	2.141
244-0063-650	2.164	244-0E02-650	2.167	248-0080-050	2.103	248-0K76-050	2.141
244-0067-650	2.164	244-0G19-050	2.164	248-0160-050	2.157	248-0L04-050	2.141
244-0085-650	2.126	244-0H64-050	2.164	248-0161-05	2.157	248-0L27-650	2.145
244-0095-650	2.126	244-0H65-050	2.164	248-0162-050	2.119	248-0L28-050	2.147
244-0118-050	2.126	244-0K95-050	2.164	248-0163-050	2.119	248-0L32-650	2.145
244-0119-050	2.126	244-0K96-050	2.164	248-0171-050	2.99	248-0L33-050	2.147
244-0120-050	2.126	244-0K97-650	2.164	248-0172-050	2.99	248-0L46-050	2.147
244-0134-050	2.126	244-0K98-650	2.164	248-0186-050	2.99	248-0L51-050	2.155
244-0135-050	2.126	244-0L26-050	2.164	248-0188-050	2.99	248-0L61-050	2.111
244-0136-050	2.126	244-0L29-050	2.164	248-0255-050	2.149	248-0L70-050	2.147
244-0137-050	2.126	244-0L37-650	2.164	248-0279-050	2.99	248-0L71-050	2.145
244-0166-050	2.126	244-0L38-650	2.164	248-0280-050	2.99	248-0L72-050	2.143
244-0167-050	2.126	244-0L39-050	2.164	248-0283-050	2.109	248-0L73-050	2.149
244-0175-650	2.164	244-0L40-050	2.164	248-0285-050	2.109	248-0M41-050	2.169
244-0232-650	2.164	244-0L50-050	2.164	248-0327-050	2.99	248-0M73-050	2.117
244-0258-050	2.124	244-0L98-050	2.164	248-0328-050	2.99	248-0N12-050	2.107
244-0259-050	2.124	244-0M28-650	2.164	248-0395-050	2.115	248-0N13-050	2.107

# Index

Item number	Page
248-0N16-050	2.109
248-0N17-050	2.109
248-0N20-050	2.109
248-0N21-050	2.109
248-0N24-050	2.111
248-0N25-050	2.111
248-0N38-050	2.145
248-0N62-050	2.111
248-0P43-050	2.155
248-0R09-050	2.169
248-0R10-050	2.155
248-0R12-050	2.155
248-0R13-050	2.117
248-0R14-050	2.117
248-0R17-050	2.117
248-0T80-050	2.159
248-0T81-050	2.159
248-0U13-050	2.159
248-0U14-050	2.159
248-0U16-050	2.121
248-0U21-050	2.121
248-0U22-050	2.121
248-0V14-050	2.101
248-0V15-050	2.121
248-0V18-050	2.105
248-0V39-050	2.101
248-0V41-050	2.101
248-0V42-050	2.101
248-0V45-050	2.105
248-0V47-050	2.105
248-0V48-050	2.105
248-0V62-050	2.103
248-0V66-050	2.149
248-1646	2.173
248-1712	2.173
248-4668	2.171
248-4672	2.171
275-4035	1.70
275-4058	1.70
277-4225	1.44
277-4355	1.44
279-9187	1.19
338-3686	1.75
338-3687	1.75
338-9721	1.75
353-3649	1.79
353-3650	1.79
360-1222	1.77
360-1230	1.77
408-3166	1.70
408-3391	1.70
408-3423	1.70
408-3424	1.70

Item number	Page
610-9099-040	4.11
610-9103-070-K1	4.13
610-9106-070-K1	4.13
610-9109-070-K1	4.13
610-9196-380	4.14
655-7F01	3.29
655-7F02	3.29
655-7F03	3.29
655-7F04	3.29
655-7F05	3.29
655-7F06	3.29
655-7F07	3.29
655-7F08	3.29
655-7F09	3.29
655-7F10	3.29
655-7F12	3.29
655-7F30	3.29
655-7F40	3.29
655-7F50	3.29
655-7F60	3.29
655-7F70	3.29
655-7F80	3.29
655-7F90	3.29
655-7H01	3.30
655-7H02	3.30
655-7H03	3.30
655-7H04	3.30
655-7H05	3.30
655-7H06	3.30
655-7H07	3.30
655-7H08	3.30
655-7H09	3.30
655-7H10	3.30
655-7H12	3.30
655-7H30	3.30
655-7H40	3.30
655-7H50	3.30
655-7H60	3.30
655-7H70	3.30
655-7H80	3.30
655-7H90	3.30
655-7L01	3.29
655-7L02	3.29
655-7L03	3.29
655-7L04	3.29
655-7L05	3.29
655-7L06	3.29
655-7L07	3.29
655-7L08	3.29
655-7L09	3.29
655-7L12	3.29
655-7L30	3.29
655-7L40	3.29

Item number	Page
655-7L50	3.29
655-7L60	3.29
655-7L70	3.29
655-7L80	3.29
655-7L90	3.29
655-7M01	3.30
655-7M02	3.30
655-7M03	3.30
655-7M04	3.30
655-7M05	3.30
655-7M06	3.30
655-7M07	3.30
655-7M08	3.30
655-7M09	3.30
655-7M10	3.30
655-7M12	3.30
655-7M30	3.30
655-7M40	3.30
655-7M50	3.30
655-7M60	3.30
655-7M70	3.30
655-7M80	3.30
655-7M90	3.30
656-0H66-380-00	3.13, 3.15
656-0H67-380-00	3.17, 3.19
656-8048	3.21, 3.23, 3.25
656-8053	3.21, 3.23, 3.25
656-8126	3.23, 3.25
656-8132	3.23, 3.25
656-8334	3.21
656-8337	3.23
656-8341	3.25
656-8352	3.13
656-8353	3.13
656-8354	3.13
656-8356	3.13
656-8357	3.13
656-8358	3.13
656-8359	3.13
656-8360	3.15
656-8361	3.15
656-8362	3.15
656-8363	3.15
656-8364	3.15
656-8365	3.15
656-8366	3.15
656-8367	3.17
656-8368	3.17

Item number	Page
656-8369	3.17
656-8370	3.17
656-8371	3.17
656-8372	3.17
656-8373	3.17
656-8374	3.19
656-8375	3.19
656-8376	3.19
656-8377	3.19
656-8378	3.19
656-8379	3.19
656-8380	3.19
656-9339	3.28
656-9340	3.28
700-0KA0-054	2.80
700-0KA1-054	2.80
700-0KA2-054	2.80
700-0KA3-054	2.80
700-0KA4-054	2.80
700-0KB0-054	2.80
700-0KB1-054	2.80
700-0KB2-054	2.80
700-0KB3-054	2.80
700-0KB4-054	2.80
700-0KC0-054	2.80
700-0KC1-054	2.80
700-0KC2-054	2.80
700-0KC3-054	2.80
700-0KC4-054	2.80
700-0KF0-054	2.80
700-0KF1-054	2.80
700-0KF2-054	2.80
700-0KF3-054	2.80
700-0KF4-054	2.80
700-0KW0-650	2.84
700-0KW3-650	2.84
700-0KW6-650	2.84
700-0KWN-054	2.84
700-0LB0-650	2.80
700-0LB2-650	2.80
700-0LB3-650	2.80
700-0LC0-650	2.80
700-0LC2-650	2.80
700-0LC3-650	2.80
700-0LF0-650	2.80
700-0LF2-650	2.80
700-0LF3-650	2.80
700-0NA0-054	2.82
700-0NA1-054	2.82
700-0NA2-054	2.82
700-0NA3-054	2.82
700-0NA4-054	2.82
700-0NA9-650	2.82

# Index

Item number	Page	Item number	Page	Item number	Page	Item number	Page
700-ONB0-054	2.82	701-OD36-650	2.39	701-OUT4-054	2.41	702-ODL4-054	2.53
700-ONB1-054	2.82	701-OD38-650	2.39	701-OW59-650	2.37	702-0E18-650	2.59
700-ONB2-054	2.82	701-OD64-650	2.31	701-OW60-650	2.37	702-0E51-650	2.57
700-ONB3-054	2.82	701-OD66-650	2.31	701-OW62-650	2.37	702-0E53-650	2.57
700-ONB4-054	2.82	701-OD70-650	2.31	701-OW63-650	2.37	702-0E57-650	2.57
700-ONC0-054	2.82	701-OD72-650	2.31	701-OW65-650	2.37	702-0E59-650	2.57
700-ONC1-054	2.82	701-OD76-650	2.31	701-OW66-650	2.37	702-0E63-650	2.57
700-ONC2-054	2.82	701-OD78-650	2.31	702-0A95-650	2.61	702-0E65-650	2.57
700-ONC3-054	2.82	701-OD82-650	2.35	702-0A97-650	2.61	702-0EK0-054	2.73
700-ONC4-054	2.82	701-OD84-650	2.35	702-0AK0-054	2.51	702-0EK1-054	2.73
700-ONC9-650	2.82	701-OD88-650	2.35	702-0AK1-054	2.51	702-0EK4-054	2.73
700-ONE0-054	2.82	701-OD90-650	2.35	702-0AK4-054	2.51	702-0EL0-054	2.73
700-ONE1-054	2.82	701-OD98-650	2.35	702-0AL0-054	2.51	702-0EL1-054	2.73
700-ONE2-054	2.82	701-ODS0-054	2.29	702-0AL1-054	2.51	702-0EL4-054	2.73
700-ONE3-054	2.82	701-ODS1-054	2.29	702-0AL4-054	2.51	702-0FK0-054	2.75
700-ONE4-054	2.82	701-ODS4-054	2.29	702-0B07-650	2.59	702-0FK1-054	2.75
700-ONF0-054	2.82	701-ODT0-054	2.29	702-0B09-650	2.59	702-0FK4-054	2.75
700-ONF1-054	2.82	701-ODT1-054	2.29	702-0BK0-054	2.51	702-0FL0-054	2.75
700-ONF2-054	2.82	701-ODT4-054	2.29	702-0BK1-054	2.51	702-0FL1-054	2.75
700-ONF3-054	2.82	701-ODT6-054	2.29	702-0BK4-054	2.51	702-0FL4-054	2.75
700-ONF4-054	2.82	701-0E32-650	2.35	702-0BL0-054	2.51	702-0GK0-054	2.75
700-ONF9-650	2.82	701-0E52-650	2.33	702-0BL1-054	2.51	702-0GK1-054	2.75
701-0A96-650	2.39	701-0E54-650	2.33	702-0BL4-054	2.51	702-0GK4-054	2.75
701-0A98-650	2.39	701-0E58-650	2.33	702-0C53-650	2.59	702-0GL0-054	2.75
701-0AS0-054	2.27	701-0E60-650	2.33	702-0C55-650	2.59	702-0GL1-054	2.75
701-0AS1-054	2.27	701-0E64-650	2.33	702-0C77-650	2.59	702-0GL4-054	2.75
701-0AS4-054	2.27	701-0E66-650	2.33	702-0C79-650	2.59	702-0UK0-054	2.63
701-0AT0-054	2.27	701-0ES0-054	2.47	702-0CK0-054	2.53	702-0UK1-054	2.63
701-0AT1-054	2.27	701-0ES1-054	2.47	702-0CK1-054	2.53	702-0UK4-054	2.63
701-0AT4-054	2.27	701-0ES4-054	2.47	702-0CK4-054	2.53	702-0UL0-054	2.63
701-0AT6-054	2.27	701-0ET0-054	2.47	702-0CL0-054	2.53	702-0UL1-054	2.63
701-0B08-650	2.35	701-0ET1-054	2.47	702-0CL1-054	2.53	702-0UL4-054	2.63
701-0B10-650	2.35	701-0ET4-054	2.47	702-0CL4-054	2.53	704-0553-054	2.69
701-0BS0-054	2.27	701-0ET6-054	2.47	702-0D29-650	2.61	704-0593-054	2.69
701-0BS1-054	2.27	701-0FS0-054	2.49	702-0D31-650	2.61	704-0595-054	2.71
701-0BS4-054	2.27	701-0FS1-054	2.49	702-0D35-650	2.61	704-0604-054	2.69
701-0BT0-054	2.27	701-0FS4-054	2.49	702-0D37-650	2.61	704-0661-054	2.69
701-0BT1-054	2.27	701-0FT0-054	2.49	702-0D63-650	2.55	704-0672-054	2.69
701-0BT4-054	2.27	701-0FT1-054	2.49	702-0D65-650	2.55	704-0673-054	2.69
701-0BT6-054	2.27	701-0FT4-054	2.49	702-0D69-650	2.55	704-0674-054	2.71
701-0C54-650	2.35	701-0FT6-054	2.49	702-0D71-650	2.55	704-0697-054	2.71
701-0C56-650	2.35	701-0GS0-054	2.49	702-0D75-650	2.55	707-0WK0-054	2.67
701-0C78-650	2.35	701-0GS1-054	2.49	702-0D77-650	2.55	707-0WK1-054	2.67
701-0C80-650	2.35	701-0GS4-054	2.49	702-0D81-650	2.59	707-0WK4-054	2.67
701-0CS0-054	2.29	701-0GT0-054	2.49	702-0D83-650	2.59	707-0WL0-054	2.67
701-0CS1-054	2.29	701-0GT1-054	2.49	702-0D87-650	2.59	707-0WL1-054	2.67
701-0CS4-054	2.29	701-0GT4-054	2.49	702-0D89-650	2.59	707-0WL4-054	2.67
701-0CT0-054	2.29	701-0GT6-054	2.49	702-0D97-650	2.59	707-0XX0-054	2.65
701-0CT1-054	2.29	701-0US0-054	2.41	702-0DK0-054	2.53	707-0XX1-054	2.65
701-0CT4-054	2.29	701-0US1-054	2.41	702-0DK1-054	2.53	707-0XX4-054	2.65
701-0CT6-054	2.29	701-0US4-054	2.41	702-0DK4-054	2.53	707-0XL0-054	2.65
701-0D30-650	2.39	701-0UT0-054	2.41	702-0DL0-054	2.53	707-0XL1-054	2.65
701-0D32-650	2.39	701-0UT1-054	2.41	702-0DL1-054	2.53	707-0XL4-054	2.65

# Index

Item number	Page
707-OYK0-054	2.65
707-OYK1-054	2.65
707-OYK4-054	2.65
707-OYLO-054	2.65
707-OYL1-054	2.65
707-OYL4-054	2.65
707-OZK0-054	2.67
707-OZK1-054	2.67
707-OZK4-054	2.67
707-OZLO-054	2.67
707-OZL1-054	2.67
707-OZL4-054	2.67
708-OWS0-054	2.45
708-OWS1-054	2.45
708-OWS4-054	2.45
708-OWT0-054	2.45
708-OWT1-054	2.45
708-OWT4-054	2.45
708-OXS0-054	2.43
708-OXS1-054	2.43
708-OXS4-054	2.43
708-OXT0-054	2.43
708-OXT1-054	2.43
708-OXT4-054	2.43
708-OYS0-054	2.43
708-OYS1-054	2.43
708-OYS4-054	2.43
708-OYT0-054	2.43
708-OYT1-054	2.43
708-OYT4-054	2.43
708-OZS0-054	2.45
708-OZS1-054	2.45
708-OZS4-054	2.45
708-OZT0-054	2.45
708-OZT1-054	2.45
708-OZT4-054	2.45
721-OPK0-650	2.77
721-OPK4-650	2.77
721-OPL0-650	2.77
721-OPL4-650	2.77
728-1283	2.173
728-1284	2.173
728-1286	2.173
728-1287	2.173
728-4669	2.171
729-OK71-054	2.183
820-6308-050	2.87, 2.89, 2.91, 2.93, 2.95, 2.97, 2.99, 2.101, 2.103, 2.105, 2.107, 2.109, 2.111, 2.115, 2.117, 2.119, 2.121, 2.131

Item number	Page
820-6308-050	2.133, 2.135, 2.137, 2.139, 2.141, 2.143, 2.145, 2.147, 2.149, 2.155, 2.157, 2.159, 2.161, 2.167, 2.169
820-6328-050	1.77, 2.27, 2.29, 2.31, 2.33, 2.35, 2.37, 2.39, 2.41, 2.43, 2.45, 2.47, 2.49, 2.51, 2.53, 2.55, 2.57, 2.59, 2.61, 2.63, 2.65, 2.67, 2.69, 2.71, 2.73, 2.75, 2.77, 2.81, 2.83, 2.125, 2.127, 2.163, 2.193, 2.197, 2.199, 2.201, 2.203
820-6350-050	2.113, 2.151, 2.153
821-6304-050	2.125, 2.163
821-6323-050	2.125, 2.163, 2.193, 2.197, 2.199
821-6332-050	2.125, 2.163
915-0320	2.199
915-0D22	2.199
915-0D22-381-K1	2.199
915-0D22-381-K2	2.199
915-0W34	2.197
915-0X59	2.199
915-0X59-381-K1	2.199
915-0X59-381-K2	2.199
915-4175	2.199
915-4183	2.199
915-7159-050	2.199, 2.201, 2.203
915-7185	2.201
915-7186	2.203
915-7187	2.201
915-7188	2.203
915-7190-050	2.199, 2.201, 2.203
915-7192	2.201
915-7193	2.203
915-7196-050	2.199, 2.201, 2.203
915-7199-050	2.199, 2.201
915-7199-050	2.203
915-9276	2.195
915-9277	2.193

Item number	Page
915-9278	2.195
915-9900-072	2.195
926-0A26-050	2.161
926-0A27-050	2.161
950-0464-050	2.153
950-0465-050	2.153
950-0466-050	2.153
950-0T26-050	2.151
950-0T27-050	2.113
950-0T49-050	2.151
950-0T50-050	2.113
950-0T51-050	2.151
950-0T52-050	2.113
951-0D45-054	2.183
951-0F15-650	2.185
972-0420	2.187
972-0X19	2.189
972-0X34	2.189
972-4564	2.187
972-4565	2.187
972-4566	2.187
973-0M99	4.9
973-0M99-380-K1	4.9
973-0X35	4.5
973-0X35-380-K1	4.5
973-0X35-380-K2	4.5
973-0X39	4.7
973-0X39-380-K1	4.7
973-0X39-380-K2	4.7
973-0X95	4.7
973-4125	4.7
973-4126	4.7
973-4451	4.5
973-4451	4.9



*Your authorized dealer*

Titus Group  
[www.titusplus.com](http://www.titusplus.com)

Titus Hardware 06.1 Eng Apr26