

Tekform
Slimline+
Drawer

Tekform Slimline+ Drawer

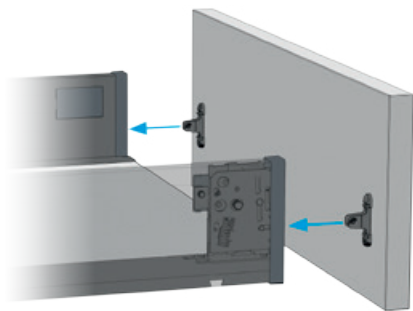

Swift assembly with enhanced front panel engagement

- Improved front panel connection ensures secure engagement and effortless disengagement

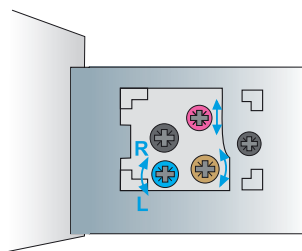

3D drawer front alignment with easy access

- Convenient front access for side, height, and tilt adjustment
- Colour-coded adjustment cams for easy identification
- Ensures uniform gap layouts for evenly aligned drawer fronts

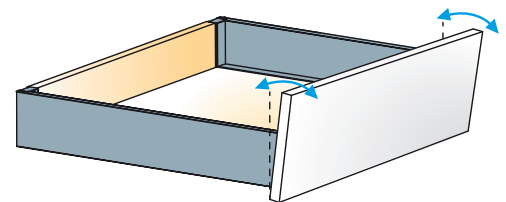

Tilt adjustment

- Accessible at the front of the drawer side
- For an intuitive drawer front positioning through the mechanical stop



Smooth and effortless performance

- Titus Damper Inside with ART function for smooth and controlled movement, regardless of the closing speed
- Low pull-out force
- Optimal closing performance and life-long consistent damping

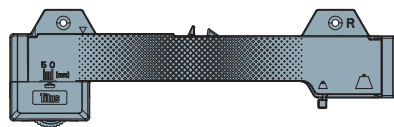

Push-to-open compatibility for handleless cabinets

- Intuitive mounting without pre-drilling
- One-for-all: one mechanism for all Tekform Slimline+ drawers from 350mm onwards
- Easily adjustable push-to-open activation with only 1.5mm gap to operate
- Same runner for standard and push-to-open application

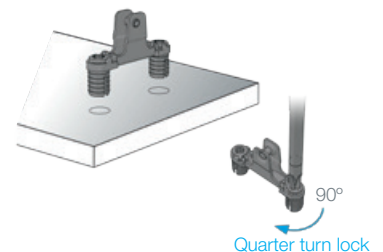

EasyFix front panel attachment

- Simple hand insertion
- Comfortable locking action at 90° turn of screwdriver
- Expando function for firm and reliable front attachment

Tekform Slimline+ Drawer

Product Guide

Page

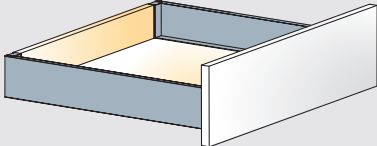
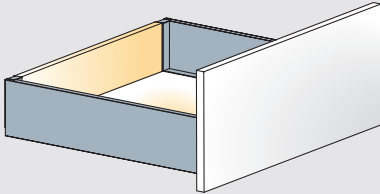
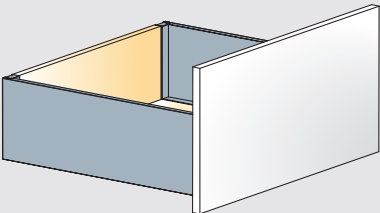
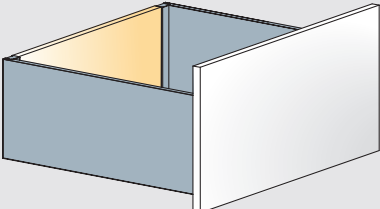
Tekform Slimline+ Drawer		Side material	Drawer type	
Tekform Slimline+ drawer DW70		Metal	Soft closing Push-to-open compatible	3.13
Tekform Slimline+ drawer DW100		Metal	Soft closing Push-to-open compatible	3.15
Tekform Slimline+ drawer DW145		Metal	Soft closing Push-to-open compatible	3.17
Tekform Slimline+ drawer DW182		Metal	Soft closing Push-to-open compatible	3.19

Page

Inner Drawer Front for Tekform Slimline+ Drawer

Inner drawer front for Tekform Slimline+ Drawer DW70

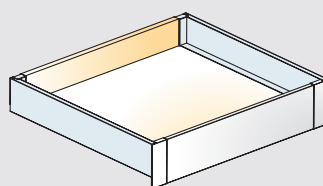

3.21

Inner drawer front for Tekform Slimline+ Drawer DW145 with bar

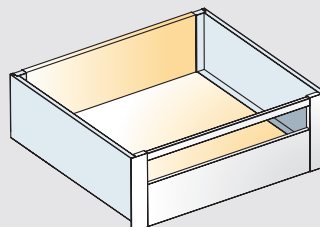

3.23

Inner drawer front for Tekform Slimline+ drawer DW182 with bar

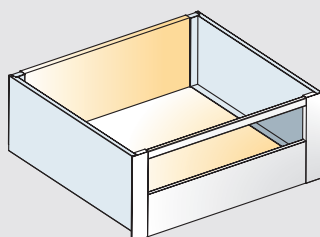

3.25

Accessories

Tacto 2.0	3.27
Marking jig	3.28
Steel back panel	3.29

Tekform Slimline Drawer

Tekform Slimline drawer DW45

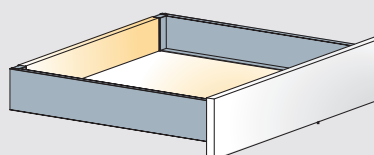

Side material	Drawer type	
Metal	Soft closing Push-to-open compatible	3.31

Tekform Slimline+ Drawer Information

Technical Guide

How to choose the appropriate drawer dimension?

Select the drawer size based on the available cabinet space. Please refer to the chart below, which indicates the

minimum space required in the cabinet to choose the appropriate drawer system.

NL = Tekform Slimline+ drawer nominal length (mm)

NL	270	300	350	400	450	500	550
----	-----	-----	-----	-----	-----	-----	-----

	Tekform Slimline+ drawer	
	Min. height H required	Cabinet depth D
Tekform Slimline+ drawer DW70	115mm	NL + min. 3mm
Tekform Slimline+ drawer DW100	147mm	NL + min. 3mm
Tekform Slimline+ drawer DW145	198mm	NL + min. 3mm
Tekform Slimline+ drawer DW182	230mm	NL + min. 3mm

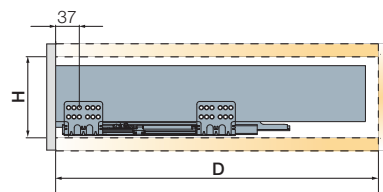

How to fix drawer sides to the front panel?

The Tekform Slimline+ drawer is available with EasyFix or screw-in front connectors



Screw-in front connector

- reliable connection
- fixing with Ø3.5x15mm screws (screws are not included)

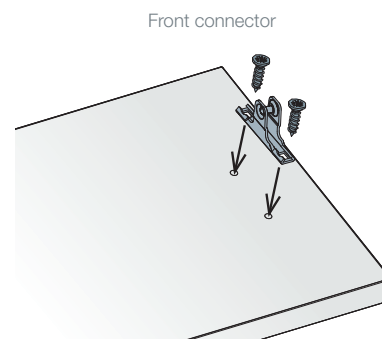

EasyFix front connector

- hand insertion
- quarter turn locking system
- expandable dowel
- easy assembly and disassembly of front panel

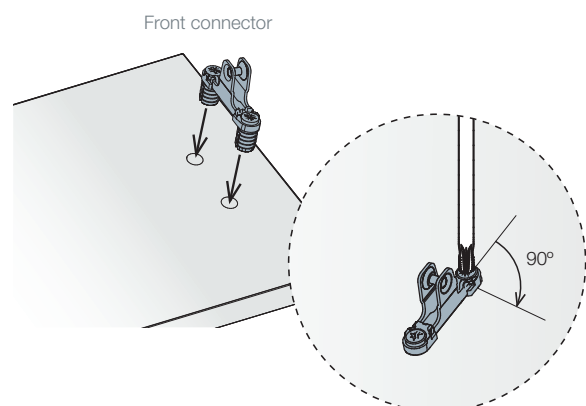

Planning

Bottom panel and back panel cutting dimensions

Dimensions of bottom and back panel depends on:

- cabinet width
- nominal drawer length
- drawer height

NL = Tekform Slimline+ drawer nominal length (mm)

NL	270	300	350	400	450	500	550
----	-----	-----	-----	-----	-----	-----	-----

Cabinet width

ECW: External cabinet width
ICW: Internal cabinet width
NL: Nominal length of drawer

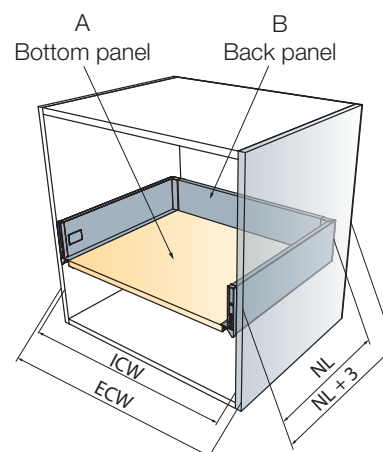

Back panel cutting dimensions

Back panel height depends on the selected drawer height

	K
DWD70	68
DWD100	100
DWD145	151
DWD182	183

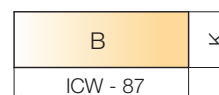

Bottom panel cutting dimensions

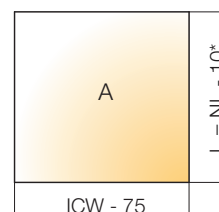

NL	270	300	350	400	450	500	550
L	260	290	340	390	440	490	540
L_{st}	250	280	330	380	430	480	530

NL = Slimline+ drawer nominal length (mm)

L = Length in case of wood back panel

L_{st}: Length in case of steel back panel

*For drawers with steel back panel L = NL - 20

Tekform Slimline+ Drawer Information

Technical Guide

How to choose the appropriate drawer runner fixing positions?

The drawer's fixing position depends on its functional placement.

Tekform Slimline+ drawer front positioned outside the carcass

When the drawer front is positioned outside the carcass, use the third hole on the drawer runner for fixing.

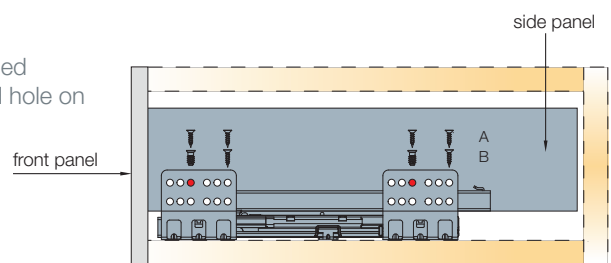

Tekform Slimline+ drawer front positioned inside the carcass

When the drawer front is positioned inside the carcass, use the second hole on the drawer runner for fixing.

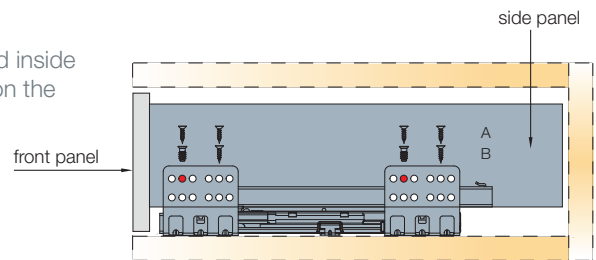

Load capacity

Drawer load capacity is 40 kg.

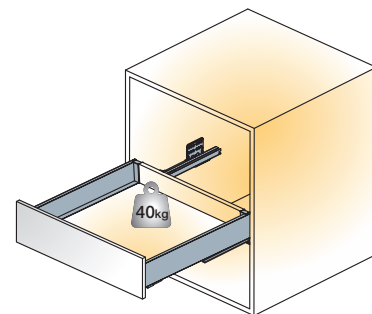

Expanded tolerances

Tekform Slimline+ drawer provides wider tolerances in cabinet construction and assures:

- precise drawer alignment
- smooth and silent operation
- improved drawer stability in open position
- Tekform Slimline+ drawer provides a tolerance of +/- 1mm on bottom panel width size

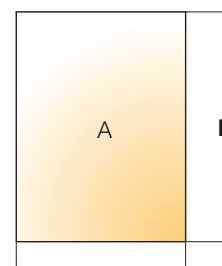

bottom panel width tolerance +/- 1mm



Adjustment needs to be done on both sides of the drawer

Adjustments

How to adjust the drawer front panel?

The Tekform Slimline+ drawer offers effortless three-dimensional front panel alignment, providing convenient access for side, height, and tilt adjustment positioned

at the front of the drawer side. Enhanced with colour-coded adjustment cams, for easy identification and precise alignment, guaranteeing uniform gap layouts.

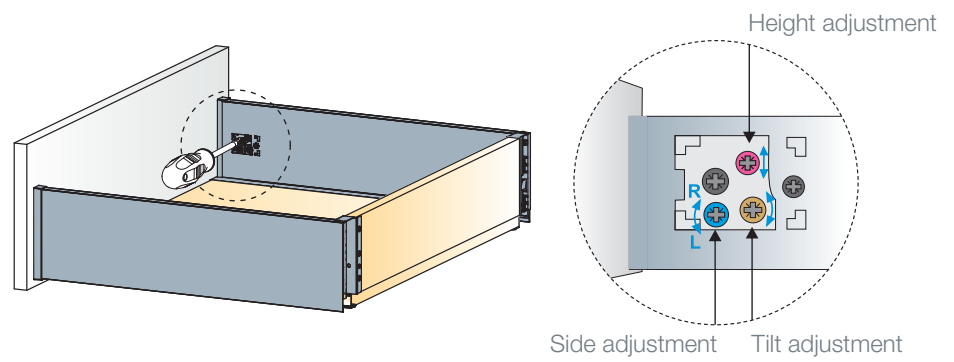

Side adjustment

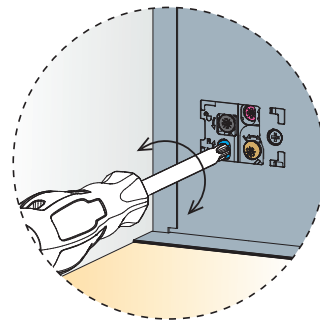
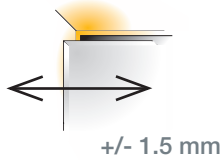

Side adjustment is done by rotating the grey coloured cam adjuster on the drawer side.

Height adjustment

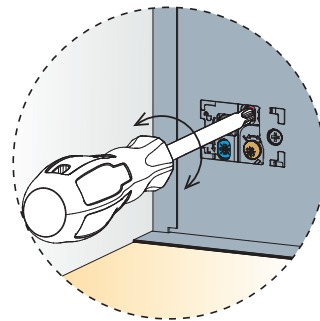
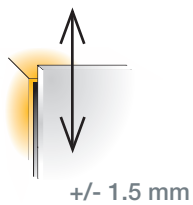

Height adjustment is done by rotating the red coloured cam adjuster on the drawer side.

Tilt adjustment

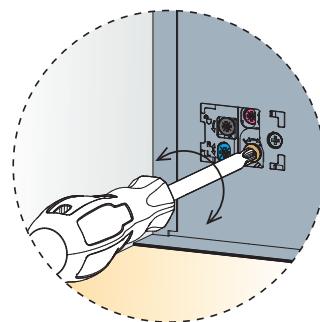
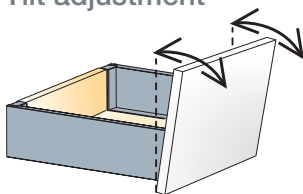

Tilt adjustment is done by rotating the yellow coloured cam adjuster on the drawer side.

Tekform Slimline+ Drawer Information

Key Design Choices

ConfidentClose

Fast closing

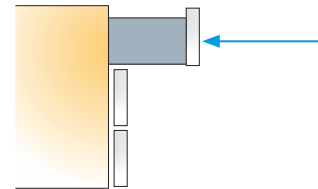

Late start of damping

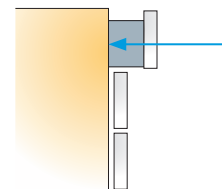

Quiet landing

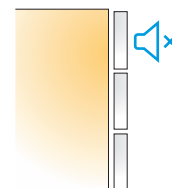

CAF Consumer Assembly Friendliness

EasyFix front panel connector with expandable dowels provides:

- Quick, toolless insertion
- Quarter turn lock
- Repeatable assembly and disassembly

Front connector

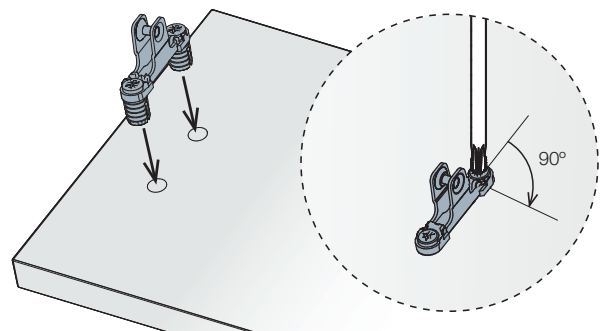

Compatible with Tacto push-opening system:

- For convenient, handle-free opening
- Same runner for both, standard and Tacto push-to-open applications
- The Tacto mechanism can be simply added as a retrofit option at any time after the drawer assembly
- For all drawers from a 300mm nominal length onwards

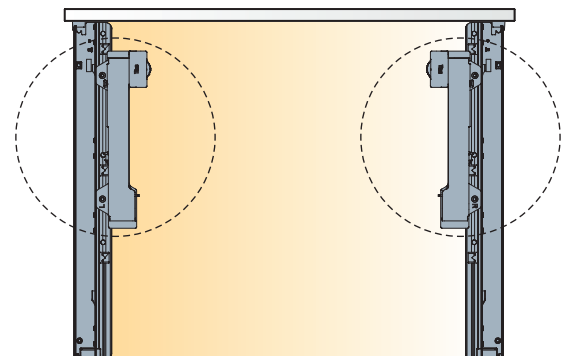

Titus Damper inside

Designed and produced in-house

- Reliable and consistent lifelong damping
- Smooth closing
- Consistent damping performance guaranteed across high-volume production runs
- 100% automated quality check



Damping action

Even and smooth soft closing action

- Soft and reliable closing

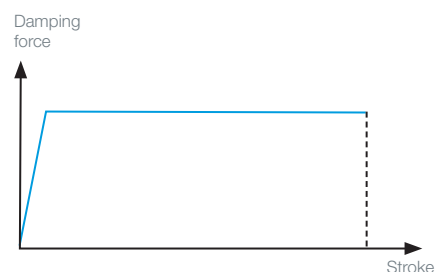

Flat damping curve shows the uniform action produced during damper closing at a defined speed.

Response to speed

Response to speed defines the increase in damping force in relation to the closing speed of the damping object.

Standard

The damping force increase is approximately linear to the increasing speed of closing.

ART - Adaptive Response Technology

Adaptive Response Technology fine-tunes the damper's performance and damping force by adjusting to the drawer's weight and speed. It provides smooth and reliable damping at any closing speed, while reducing the force needed to open the drawer.

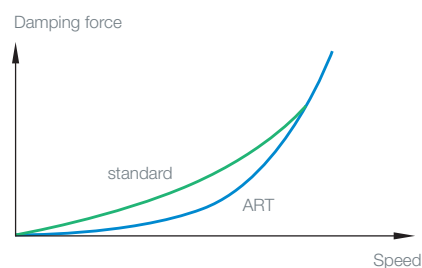

Tekform Slimline+ Drawer DW70

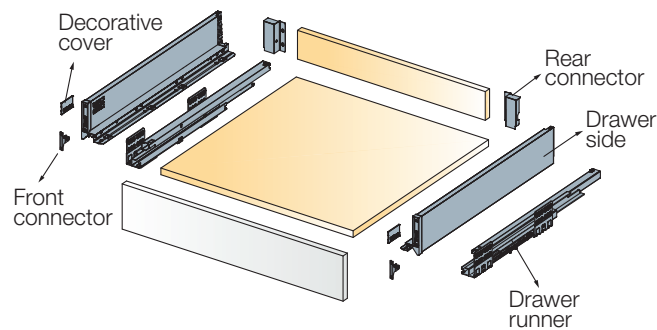
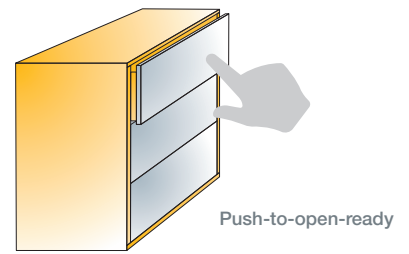

Cutting dimensions details

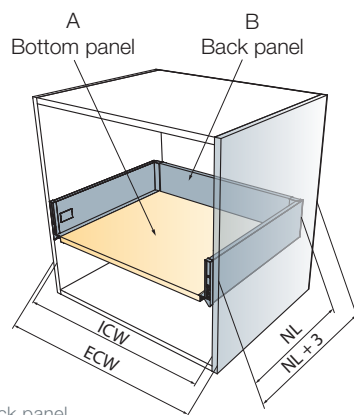

ECW: External cabinet width
ICW: Internal cabinet width
NL: Nominal length of drawer
L_{st}: Length in case of steel back panel

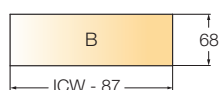
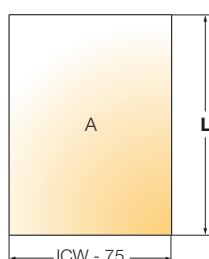







$L = NL - 10$
 $L_{st} = NL - 20$
For further explanation → see page 3.8



4 sets

Nominal length (mm)	with Screw-in front connector 		
		White	Anthracite
270	656-8352 →	150	185
300	656-8353 →	150	185
350	656-8354 →	150	185
400	656-8356 →	150	185
450	656-8357 →	150	185
500	656-8358 →	150	185
550	656-8359 →	150	185

One set consists of

Drawer sides		2 pcs
Drawer runners		2 pcs
Front connectors		2 pcs
Rear connectors		2 pcs
Decorative covers		2 pcs
Mounting instructions		1 pc/4 sets

Push opening



Tacto Slimline Mechanism
→ see page 3.27

EasyFix front connector



656-0H66-380-00

 400 Pcs

- Drawer runner type
- Load capacity
- Minimum height space required
- Drawer side thickness
- Wooden back panel thickness
- Wooden bottom panel thickness

full extension
40 kg
115mm
14mm
16mm
16mm

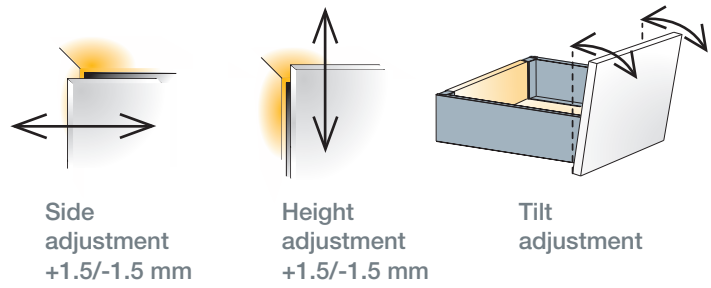

i Works with Tacto Push Opening Mechanism
→ see page 3.27

For further explanation → see page 3.10

Installation dimensions and drillings

Drawer runner fixing positions

Front panel

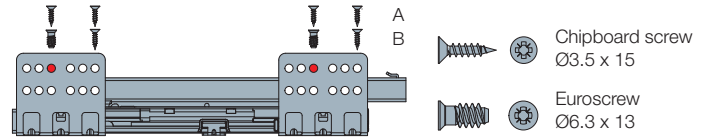
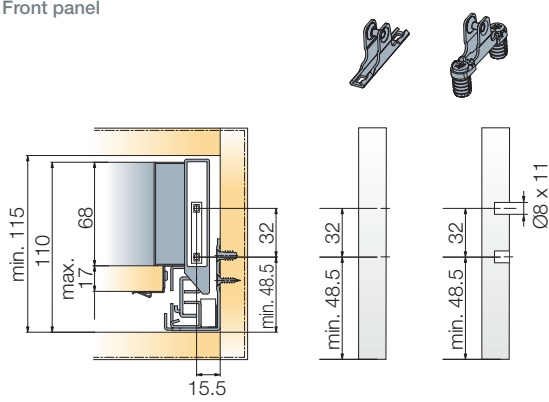

NL=270mm
NL=300mm
NL=350mm
NL=400mm
NL=450mm

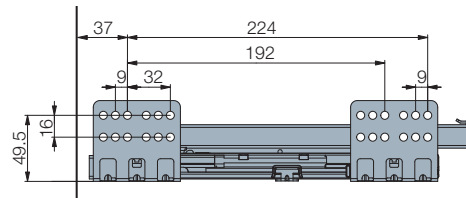

Back panel

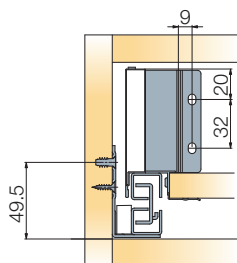

NL=500mm
NL=550mm

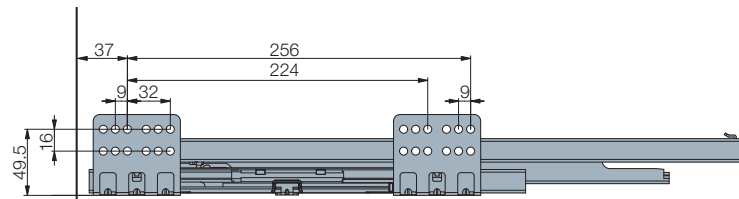

Assembly instructions, adjustments



Tekform Slimline+ Drawer DW100

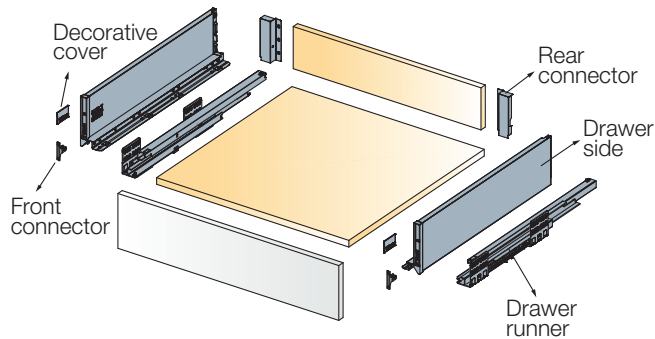
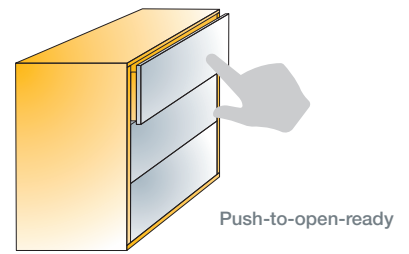

Cutting dimensions details

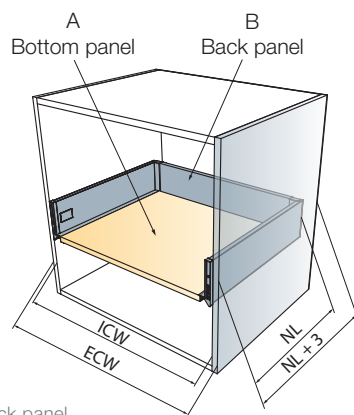

ECW: External cabinet width
ICW: Internal cabinet width
NL: Nominal length of drawer
L_{st}: Length in case of steel back panel

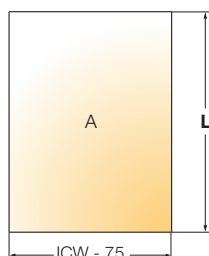





$L = NL - 10$
 $L_{st} = NL - 20$
For further explanation → see page 3.8

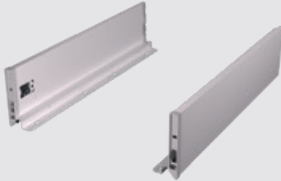

4 sets

NL	with Screw-in front connector 		
		White	Anthracite
Nominal length (mm)	Item number for a set		
270	656-8360 →	150	185
300	656-8361 →	150	185
350	656-8362 →	150	185
400	656-8363 →	150	185
450	656-8364 →	150	185
500	656-8365 →	150	185
550	656-8366 →	150	185

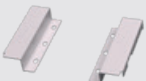
One set consists of

Drawer sides		2 pcs
Drawer runners		2 pcs
Front connectors		2 pcs
Rear connectors		2 pcs
Decorative covers		2 pcs
Mounting instructions		1 pc/4 sets

Push opening



Tacto Slimline Mechanism
→ see page 3.27

EasyFix front connector



656-0H66-380-00

 400 Pcs

- Drawer runner type
- Load capacity
- Minimum height per drawer required
- Drawer side thickness
- Wooden back panel thickness
- Wooden bottom panel thickness

full extension
40 kg
147mm
14mm
16mm
16mm

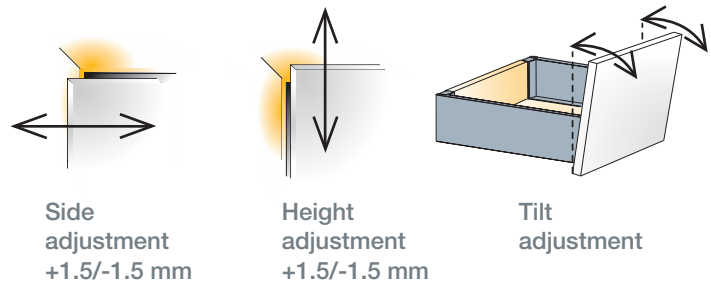

i Works with Tacto Push Opening Mechanism
→ see page 3.27

For further explanation → see page 3.10

Installation dimensions and drillings

Drawer runner fixing positions

Front panel

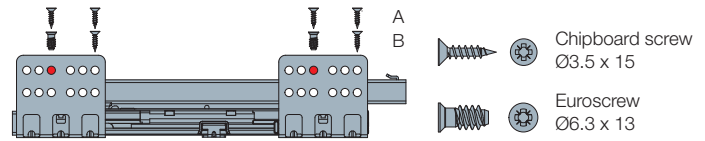
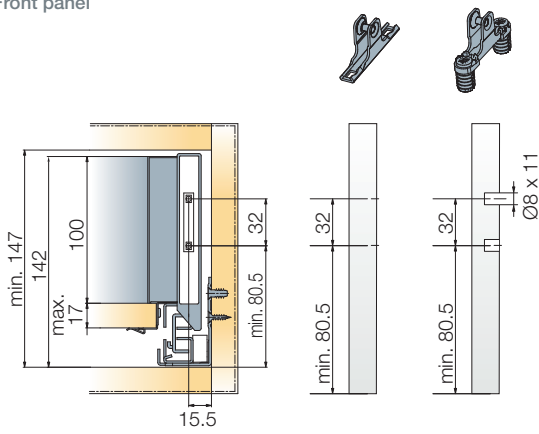

NL=270mm
NL=300mm
NL=350mm
NL=400mm
NL=450mm

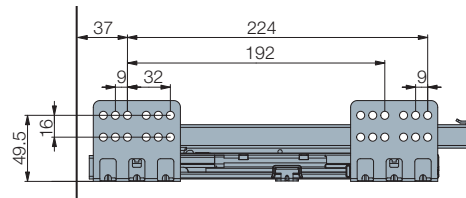

Back panel

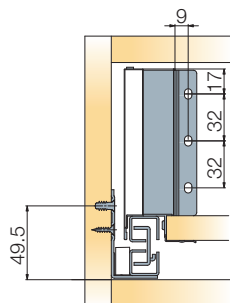

NL=500mm
NL=550mm

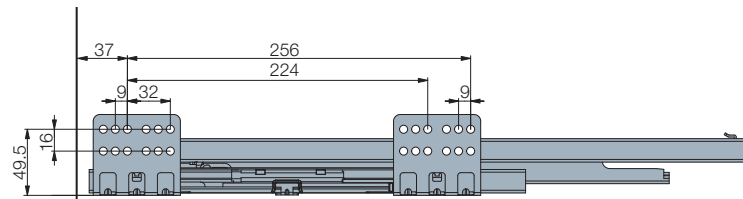

Assembly instructions, adjustments



Tekform Slimline+ Drawer DW145

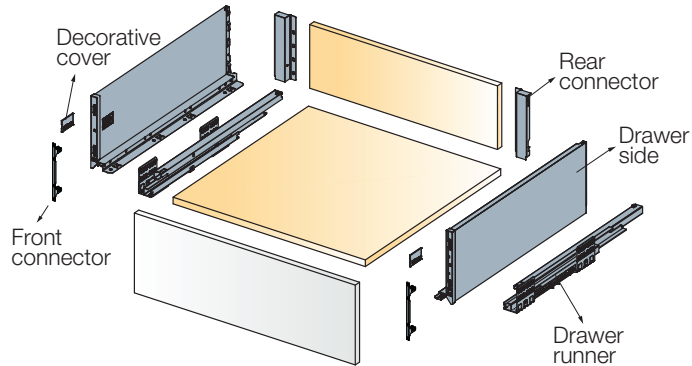
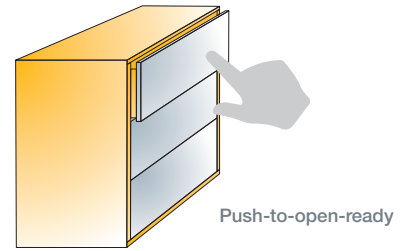

Cutting dimensions details

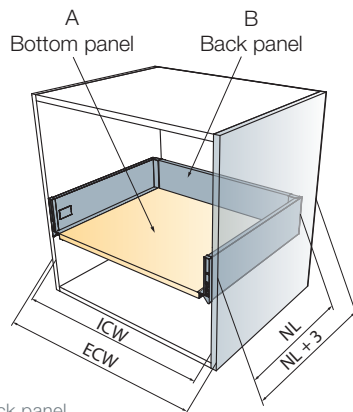

ECW: External cabinet width
 ICW: Internal cabinet width
 NL: Nominal length of drawer
 L_{st}: Length in case of steel back panel

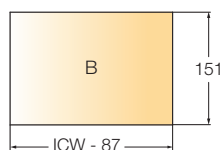
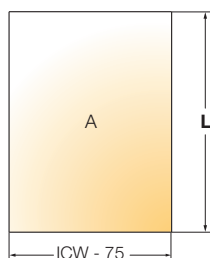

$L = NL - 10$
 $L_{st} = NL - 20$
 For further explanation → see page 3.8



Nominal length (mm)	with Screw-in front connector 		
		White	Anthracite
270	656-8367 →	150	185
300	656-8368 →	150	185
350	656-8369 →	150	185
400	656-8370 →	150	185
450	656-8371 →	150	185
500	656-8372 →	150	185
550	656-8373 →	150	185

One set consists of

Drawer sides		2 pcs
Drawer runners		2 pcs
Front connectors		2 pcs
Rear connectors		2 pcs
Decorative covers		2 pcs
Mounting instructions		1 pc/4 sets

Push opening



Tacto Slimline Mechanism
 → see page 3.27

EasyFix front connector



656-0H67-380-00

 400 Pcs

- Drawer runner type
- Load capacity
- Minimum height per drawer required
- Drawer side thickness
- Wooden back panel thickness
- Wooden bottom panel thickness

full extension
40 kg
198mm
14mm
16mm
16mm

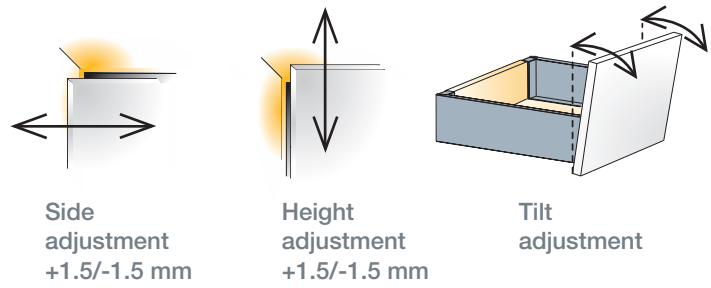

i Works with Tacto Push Opening Mechanism
→ see page 3.27

For further explanation → see page 3.10

Installation dimensions and drillings

Drawer runner fixing positions

Front panel

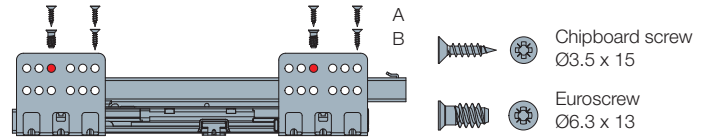
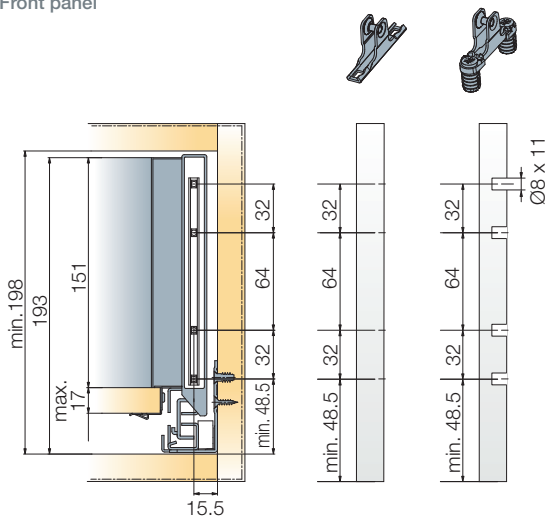

NL=270mm
NL=300mm
NL=350mm
NL=400mm
NL=450mm

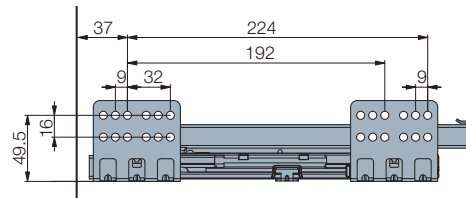

NL=500mm
NL=550mm

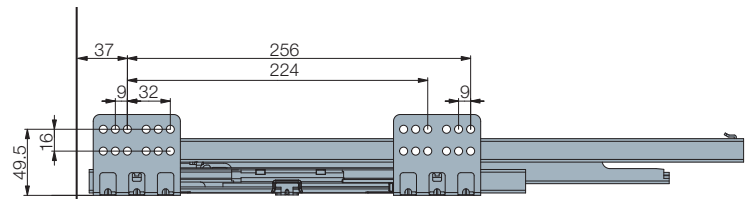

Back panel

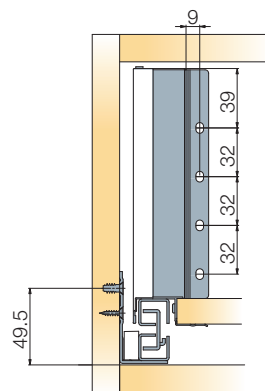

Assembly instructions, adjustments



A trial mounting is always recommended.
For further information please contact your
Titus Group representative.

Tekform Slimline+ Drawer DW182

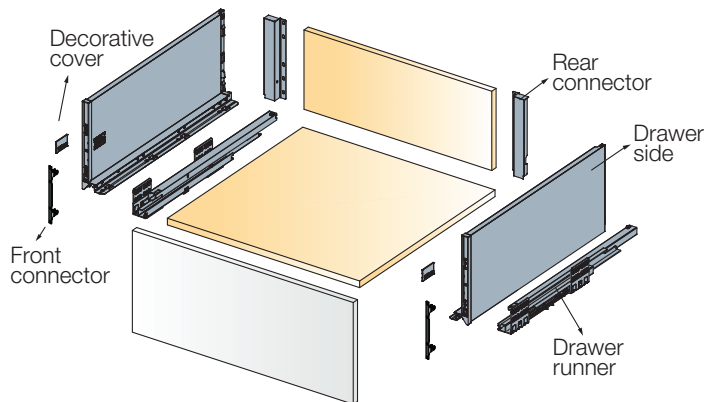
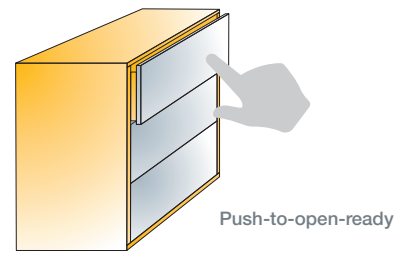

Cutting dimensions details

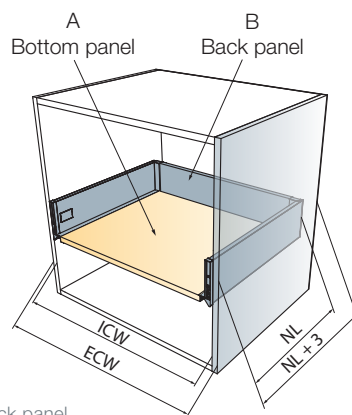

ECW: External cabinet width
 ICW: Internal cabinet width
 NL: Nominal length of drawer
 L_{st}: Length in case of steel back panel

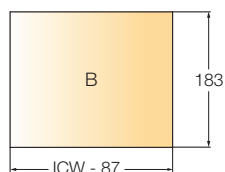
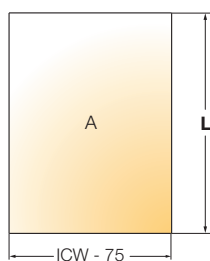

$L = NL - 10$
 $L_{st} = NL - 20$
 For further explanation → see page 3.8



Nominal length (mm)	with Screw-in front connector 		
		White	Anthracite
270	656-8374 →	150	185
300	656-8375 →	150	185
350	656-8376 →	150	185
400	656-8377 →	150	185
450	656-8378 →	150	185
500	656-8379 →	150	185
550	656-8380 →	150	185

One set consists of

Drawer sides		2 pcs
Drawer runners		2 pcs
Front connectors		2 pcs
Rear connectors		2 pcs
Decorative covers		2 pcs
Mounting instructions		1 pc/4 sets

Push opening



Tacto Slimline Mechanism
 → see page 3.27

EasyFix front connector



656-0H67-380-00

 400 Pcs

- Drawer runner type
- Load capacity
- Minimum height per drawer required
- Drawer side thickness
- Wooden back panel thickness
- Wooden bottom panel thickness

full extension
40kg
230mm
14mm
16mm
16mm

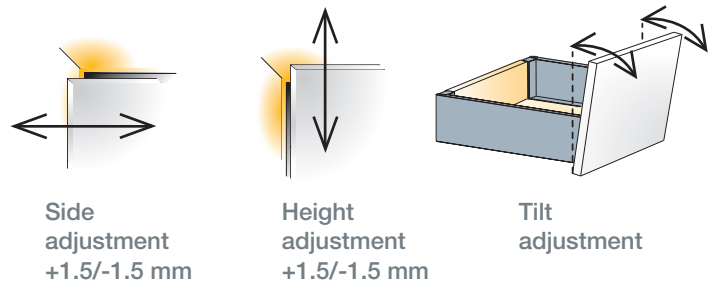

i Works with Tacto Push Opening Mechanism
→ see page 3.27

For further explanation → see page 3.10

Installation dimensions and drillings

Drawer runner fixing positions

Front panel

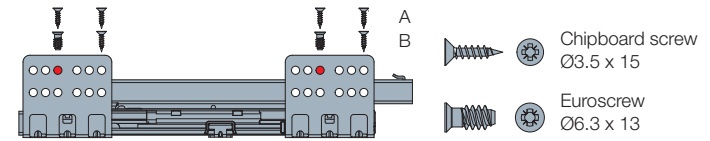
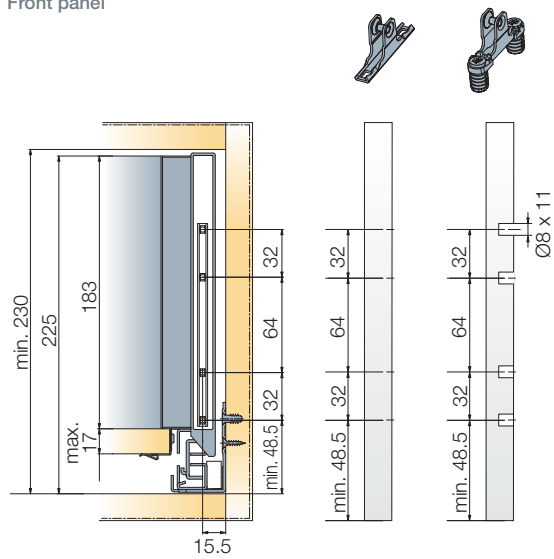

NL=270mm
NL=300mm
NL=350mm
NL=400mm
NL=450mm

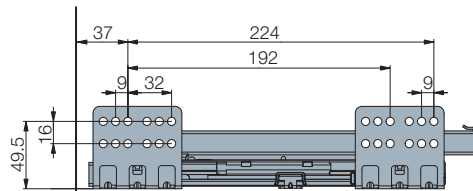

NL=500mm
NL=550mm

Back panel

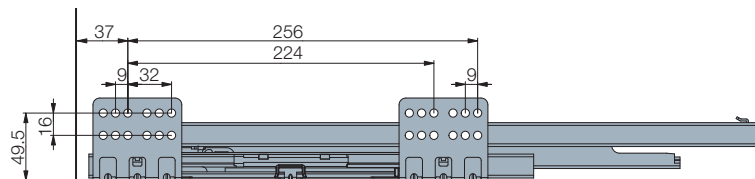
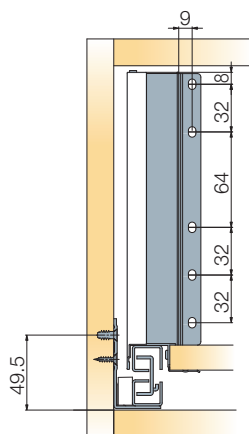

Assembly instructions, adjustments



A trial mounting is always recommended.
For further information please contact your
Titus Group representative.

Inner Drawer Front for Tekform Slimline+ Drawer DW70

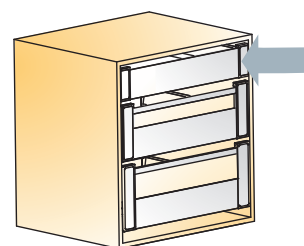

Front panel

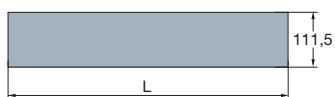

Cutting dimension L = ICW-105
ICW → see page 3.22

 20 pcs

Made of aluminium

Front bracket



 50 sets

Made of aluminium and plastic

External cabinet width	Item number	White	Antracite grey
		600	656-8048 →
1200	656-8053 →	511	515
		656-8334 →	350 385

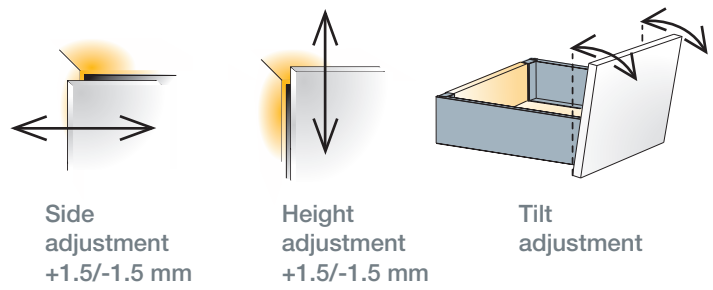
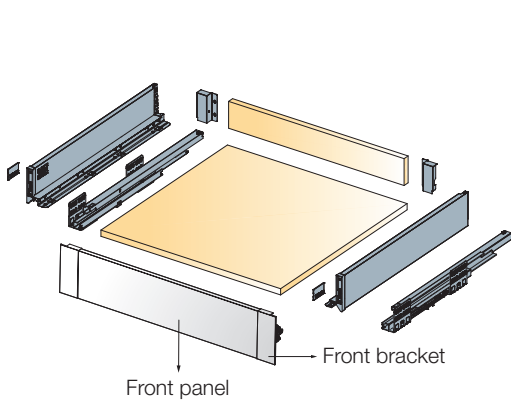

For further explanation → see page 3.10

Installation dimensions

Drawer runner fixing positions

Cutting dimensions details

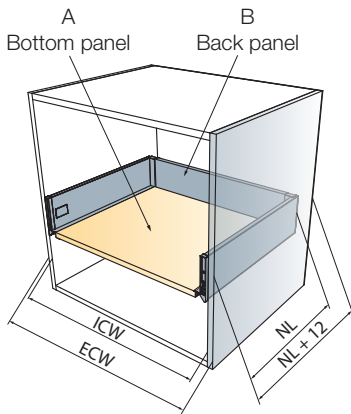

ECW: External cabinet width
ICW: Internal cabinet width
NL: Nominal length of drawer

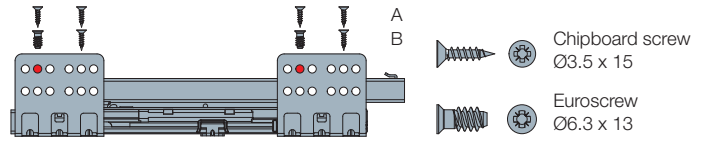

NL=270mm
NL=300mm
NL=350mm
NL=400mm
NL=450mm

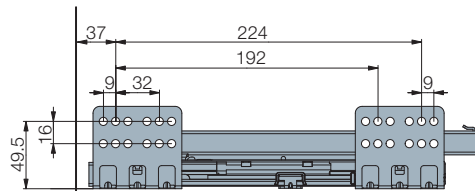

NL=500mm
NL=550mm

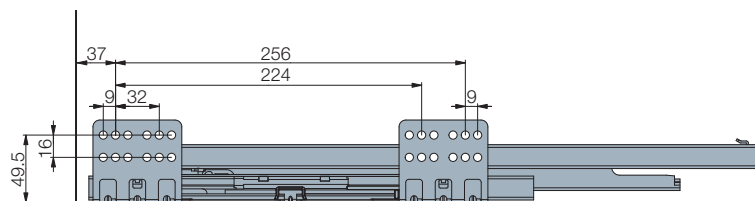

Assembly instructions, adjustments



Inner Drawer Front for Tekform Slimline+ Drawer DW145 with Bar

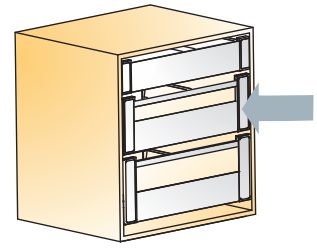

Front bar

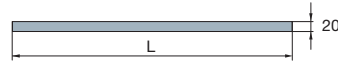

Cutting dimension L = ICW-94
ICW → see page 3.24

 50 pcs

Made of aluminium

Front panel



Cutting dimension L = ICW-105
ICW → see page 3.24

 20 pcs

Made of aluminium

Front bracket



 20 pcs

Made of aluminium and plastic

External cabinet width	Item number	Color	
		White	Antracite grey
600	656-8126 →	511	515
1200	656-8132 →	511	515
600	656-8048 →	511	515
1200	656-8053 →	511	515
	656-8337 →	350	385

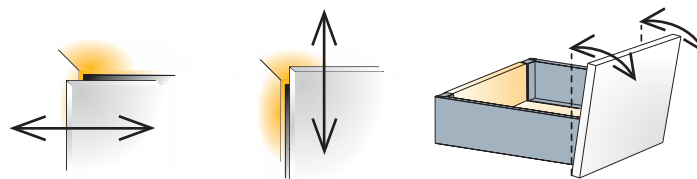
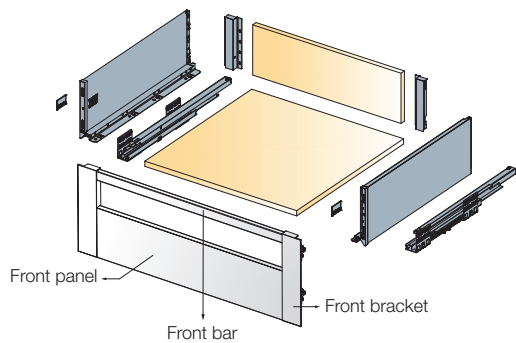

Side adjustment
+1.5/-1.5 mm

Height adjustment
+1.5/-1.5 mm

Tilt adjustment

For further explanation → see page 3.10

Installation dimensions

Drawer runner fixing positions

Cutting dimensions details

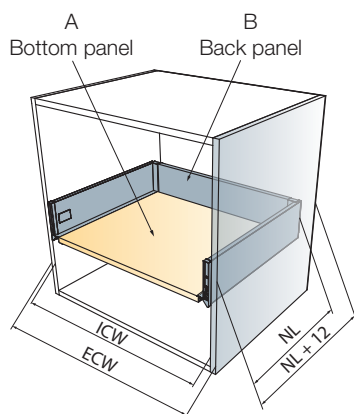

ECW: External cabinet width
ICW: Internal cabinet width
NL: Nominal length of drawer

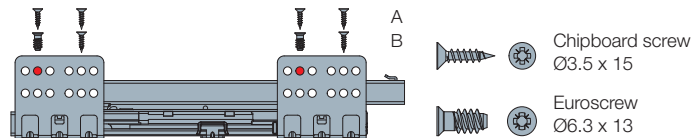

NL=270mm
NL=300mm
NL=350mm
NL=400mm
NL=450mm

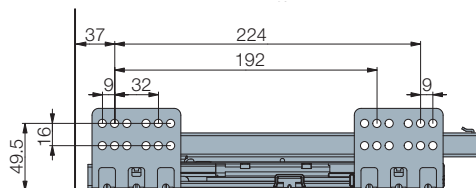

NL=500mm
NL=550mm

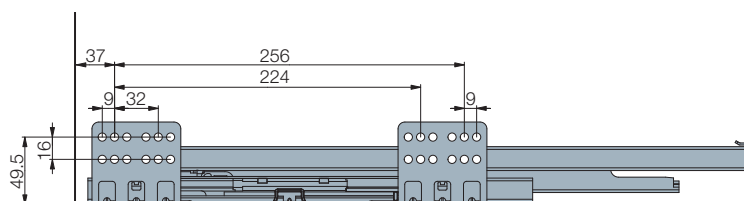

Assembly instructions, adjustments



Inner Drawer Front for Tekform Slimline+ Drawer DW182 with Bar

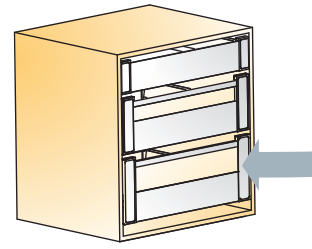

Front bar



Cutting dimension L = ICW-94
ICW → see page 3.26

 50 pcs

Made of aluminium and plastic

Front panel

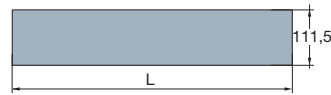

Cutting dimension L = ICW-105
ICW → see page 3.26

 20 pcs

Made of aluminium

Front bracket



 20 sets

Made of aluminium and plastic

External cabinet width	Item number	Color	
		White	Antracite grey
600	656-8126 →	511	515
1200	656-8132 →	511	515
600	656-8048 →	511	515
1200	656-8053 →	511	515
	656-8341 →	350	385

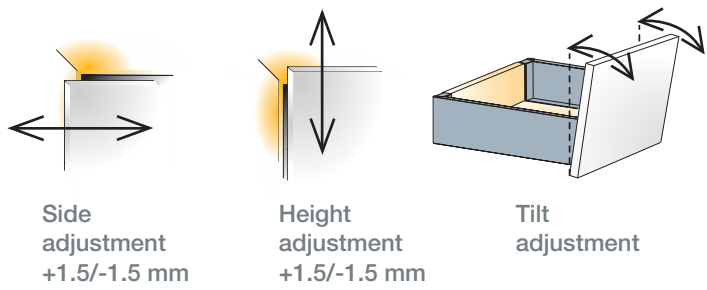
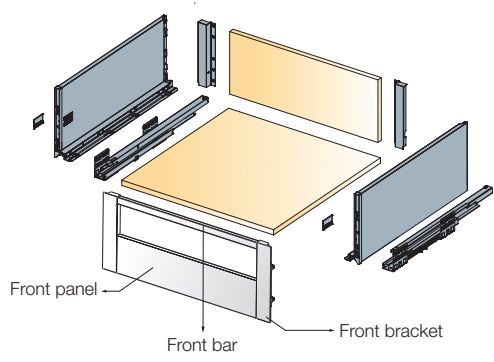

For further explanation → see page 3.10

Installation dimensions

Drawer runner fixing positions

Cutting dimensions details

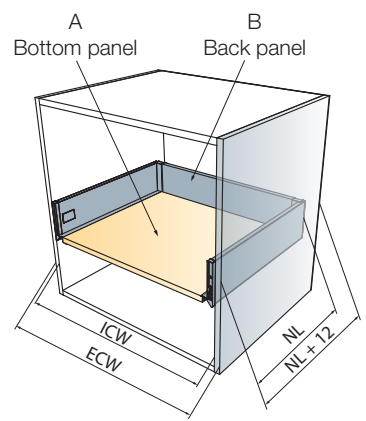

ECW: External cabinet width
ICW: Internal cabinet width
NL: Nominal length of drawer

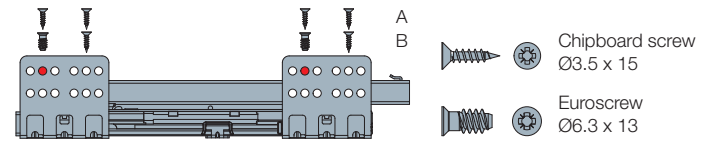

- NL=270mm
- NL=300mm
- NL=350mm
- NL=400mm
- NL=450mm

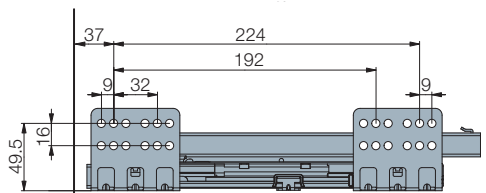

- NL=500mm
- NL=550mm

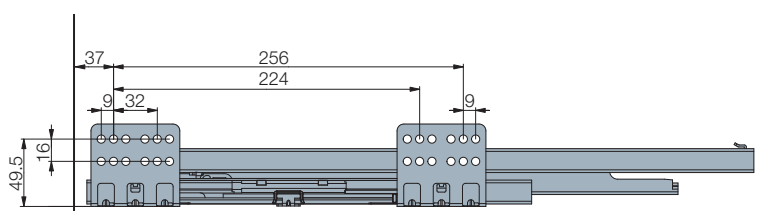

Assembly instructions, adjustments



TouchControl Solutions

Tacto 2.0

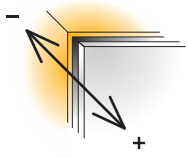

Front gap adjustment
-1.5/+3.5mm



"Push-to-Open"

- Intuitive mounting
- One-for-all – One item fits all Slimline+ drawers from NL=300mm
- Easily adjustable push-to-open activation with only 1.5mm gap to operate
- Easy opening, reliable closing

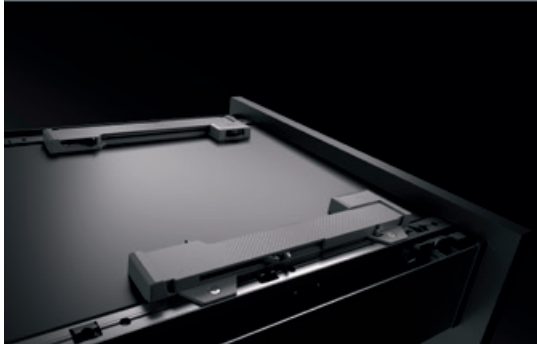

Technical details

Item number for set

Tacto 2.0

656-9220-383-K1



One set consists of

PushOpen Mechanism



2 pcs

Tacto Activator



2 pcs

Chipboard screws



4 pcs/set

Mounting instructions



1 pc/set

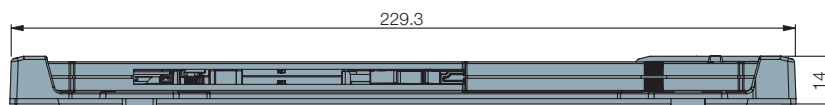
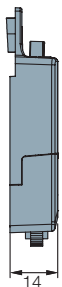
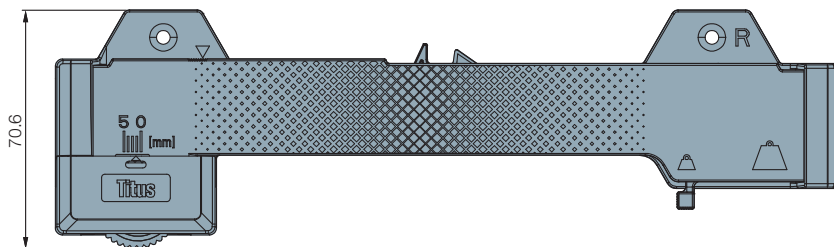

Assembly instructions, adjustments



 30 sets

Made of plastic

Accessories

Marking Jig

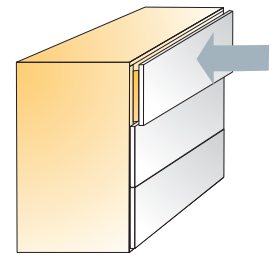

Tekform Slimline+ Drawer

Marking jig for Tekform Slimline+ drawer DW70 and DW100

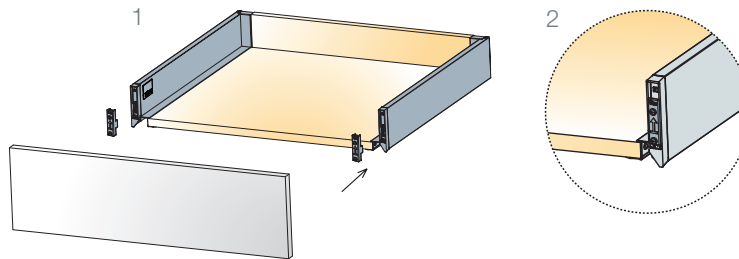

1 set

Made of plastic and steel

Marking jig for Tekform Slimline+ drawer DW145 and DW182

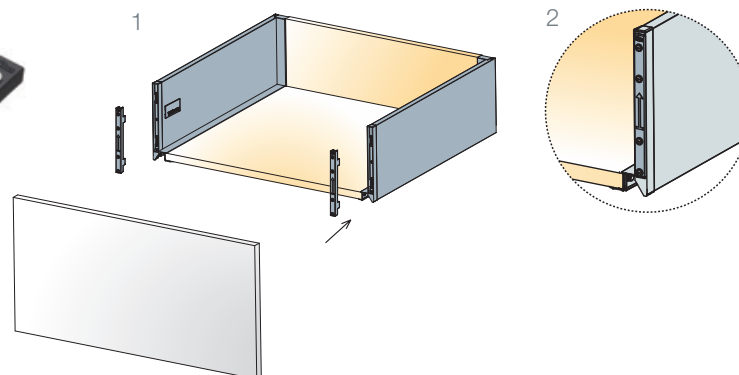

1 set

Made of plastic and steel

Item number

656-9339

Black

390





656-9340



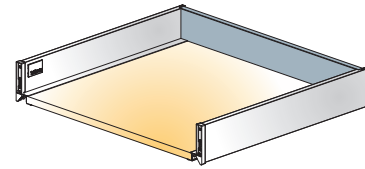

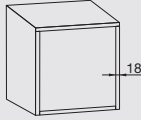
390

Accessories

Steel Back Panel

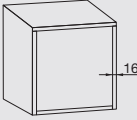
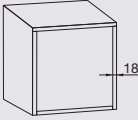

	ECW	Cabinet side thickness 16mm	Cabinet side thickness 18mm		
				White	Anthracite
	External cabinet width (mm)				
Steel back panel DW70 	300	655-7L01	655-7L30	150	185
	400	655-7L02	655-7L40	150	185
	500	655-7L03	655-7L50	150	185
	600	655-7L04	655-7L60	150	185
	700	655-7L05	655-7L70	150	185
	800	655-7L06	655-7L80	150	185
	900	655-7L07	655-7L90	150	185
	1000	655-7L08	655-7L10	150	185
	1200	655-7L09	655-7L12	150	185
	 10 pcs Made of steel				
Steel back panel DW100 	300	655-7F01	655-7F30	150	185
	400	655-7F02	655-7F40	150	185
	500	655-7F03	655-7F50	150	185
	600	655-7F04	655-7F60	150	185
	700	655-7F05	655-7F70	150	185
	800	655-7F06	655-7F80	150	185
	900	655-7F07	655-7F90	150	185
	1000	655-7F08	655-7F10	150	185
	1200	655-7F09	655-7F12	150	185
	 10 pcs Made of steel				

	ECW	Cabinet side thickness 16mm	Cabinet side thickness 18mm		
				White	Anthracite
External cabinet width (mm)					
Steel back panel DW145 	300	655-7M01	655-7M30	150	185
	400	655-7M02	655-7M40	150	185
	500	655-7M03	655-7M50	150	185
	600	655-7M04	655-7M60	150	185
	700	655-7M05	655-7M70	150	185
	800	655-7M06	655-7M80	150	185
	900	655-7M07	655-7M90	150	185
	1000	655-7M08	655-7M10	150	185
	1200	655-7M09	655-7M12	150	185
	 10 pcs Made of steel				
Steel back panel DW182 	300	655-7H01	655-7H30	150	185
	400	655-7H02	655-7H40	150	185
	500	655-7H03	655-7H50	150	185
	600	655-7H04	655-7H60	150	185
	700	655-7H05	655-7H70	150	185
	800	655-7H06	655-7H80	150	185
	900	655-7H07	655-7H90	150	185
	1000	655-7H08	655-7H10	150	185
	1200	655-7H09	655-7H12	150	185
	 10 pcs Made of steel				

Tekform Slimline DW45

Shallow Drawer

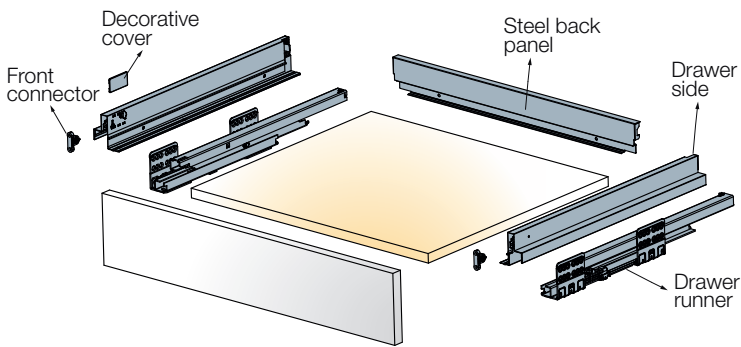
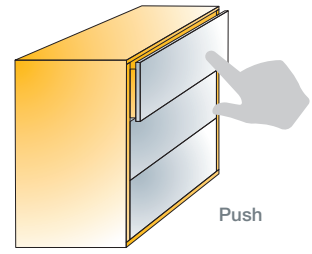



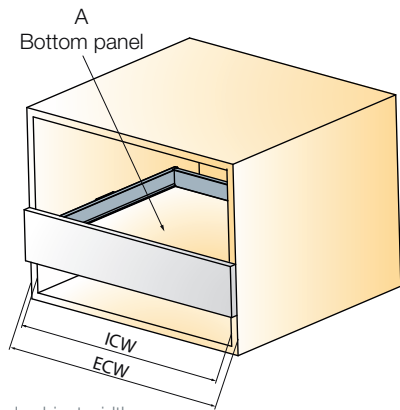

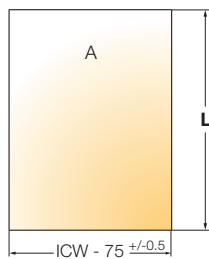

Cutting dimensions details

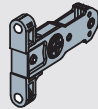

ECW: External cabinet width
 ICW: Internal cabinet width
 NL: Nominal length of drawer
 L_{st} : Length in case of steel back panel



L_{st} : NL - 20
 For further explanation
 → see page 3.8

NL	with Screw-in front connector		
Nominal length (mm)			
		White	Antracite
Item number for a set			
450	655-8046	150	185
500	655-8047	150	185
To be ordered separately Steel back panel			
600*	655-7273	150	185
* cabinet side thickness 18mm			
One set consists of			
Drawer sides		2 pcs	
Drawer runners		2 pcs	
*Front connectors		2 pcs	
Covers		2 pcs	
Mounting instructions		1 pc/4 sets	

Screws are not included

- Drawer runner type
- Load capacity
- Minimum height space required
- Back panel
- Wooden bottom panel thickness

full extension
40 kg
76mm
steel
16mm

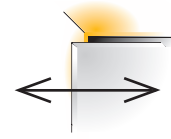

Side adjustment
+1/-1mm

i Works with or without Tacto Mechanism

Installation dimensions

Minimum space required for the cabinet

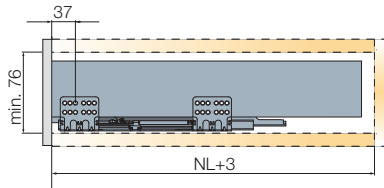

Drawer runner fixing positions

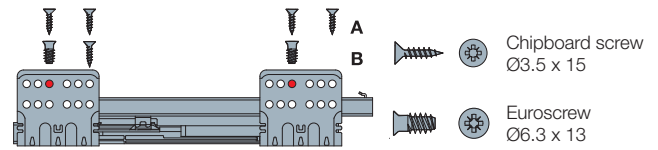

Drilling dimensions for the front panel

Screw-in attachment

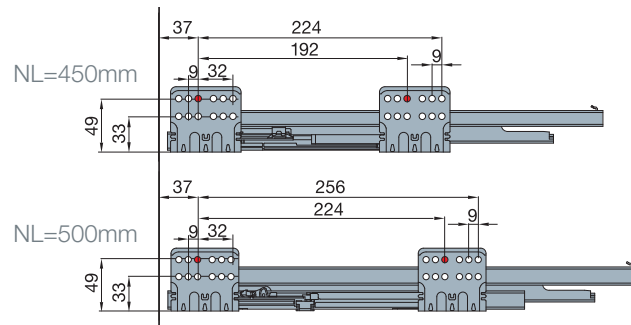
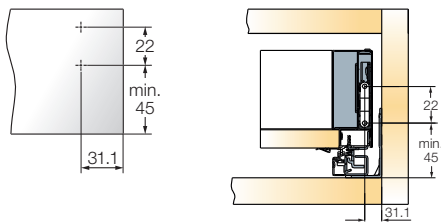

A trial mounting is always recommended.
For further information please contact your Titus Group representative.

