

# Tekform Slimline DW45

## Shallow Drawer

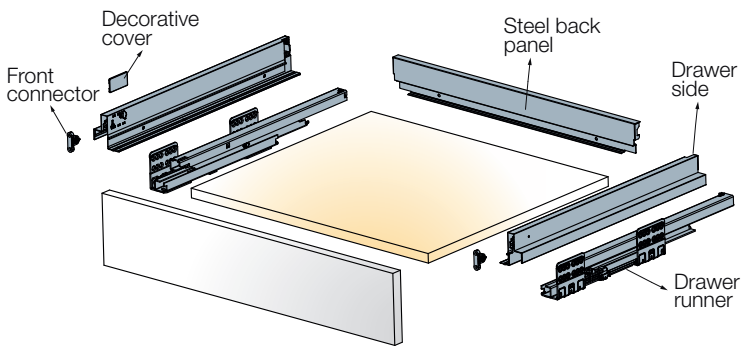

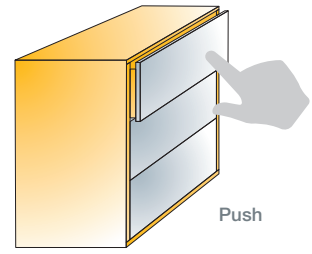

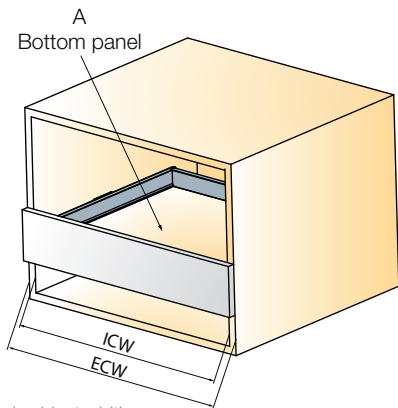

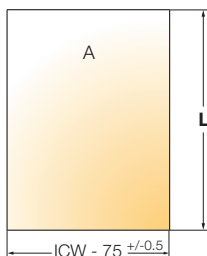

### Cutting dimensions details

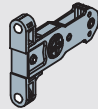

ECW: External cabinet width  
 ICW: Internal cabinet width  
 NL: Nominal length of drawer  
 $L_{st}$ : Length in case of steel back panel



$L_{st}$ : NL - 20  
 For further explanation  
 → see page 3.8

NL	with Screw-in front connector		
		White	Antracite
Nominal length (mm)		Item number for a set	
		450	655-8046
500	655-8047	150	185
To be ordered separately Steel back panel			
600*	655-7273	150	185
* cabinet side thickness 18mm			
One set consists of			
Drawer sides		2 pcs	
Drawer runners		2 pcs	
*Front connectors		2 pcs	
Covers		2 pcs	
Mounting instructions		1 pc/4 sets	

Screws are not included

- Drawer runner type
- Load capacity
- Minimum height space required
- Back panel
- Wooden bottom panel thickness

full extension  
40 kg  
76mm  
steel  
16mm

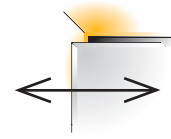

Side adjustment  
+1/-1mm

**i** Works with or without Tacto Mechanism

Installation dimensions

Minimum space required for the cabinet

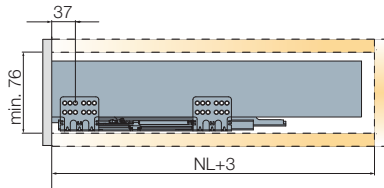

Drawer runner fixing positions

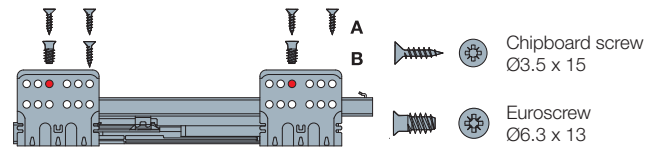

Drilling dimensions for the front panel

Screw-in attachment

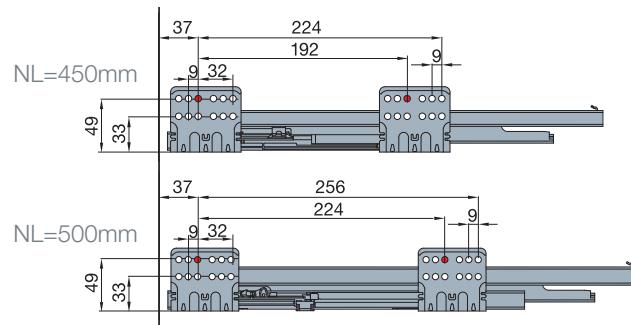
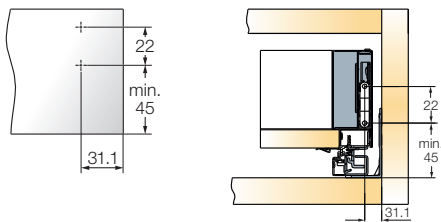

A trial mounting is always recommended.  
For further information please contact your Titus Group representative.