

Tekform Slimline DW45

Shallow Drawer

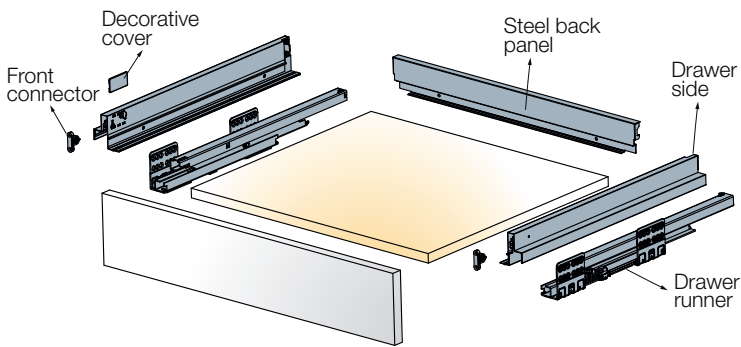

Cutting dimensions details

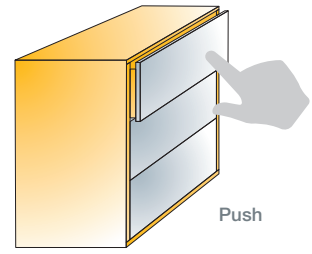
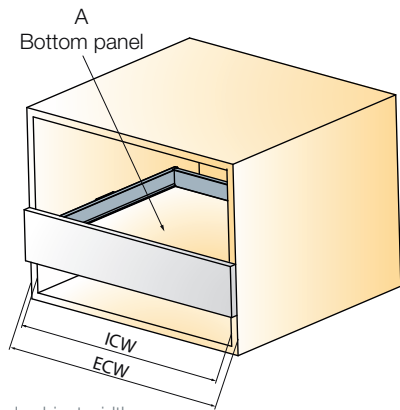

ECW: External cabinet width
 ICW: Internal cabinet width
 NL: Nominal length of drawer
 L_{st} : Length in case of steel back panel

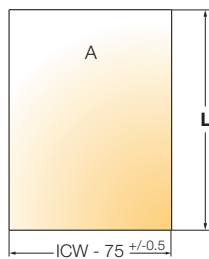

L_{st} : NL - 20
 For further explanation
 → see page 3.8

NL	with Screw-in front connector	Nominal length (mm)	Colors	
			White	Antracite
450	655-8046		150	185
500	655-8047		150	185
To be ordered separately Steel back panel				
600*	655-7273		150	185
* cabinet side thickness 18mm				
One set consists of				
Drawer sides			2 pcs	
Drawer runners			2 pcs	
*Front connectors			2 pcs	
Covers			2 pcs	
Mounting instructions			1 pc/4 sets	

Screws are not included

- Drawer runner type
- Load capacity
- Minimum height space required
- Back panel
- Wooden bottom panel thickness

full extension
40 kg
76mm
steel
16mm

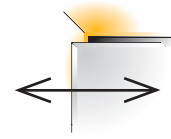

Side adjustment
+1/-1mm

i Works with or without Tacto Mechanism

Installation dimensions

Minimum space required for the cabinet

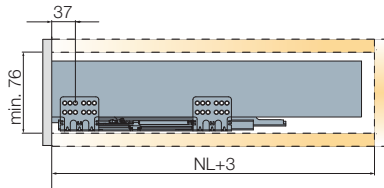

Drawer runner fixing positions

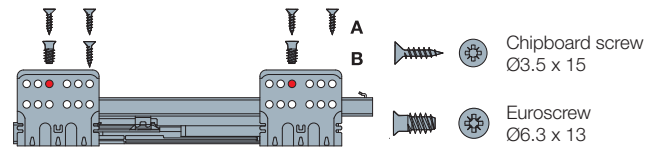

Drilling dimensions for the front panel

Screw-in attachment

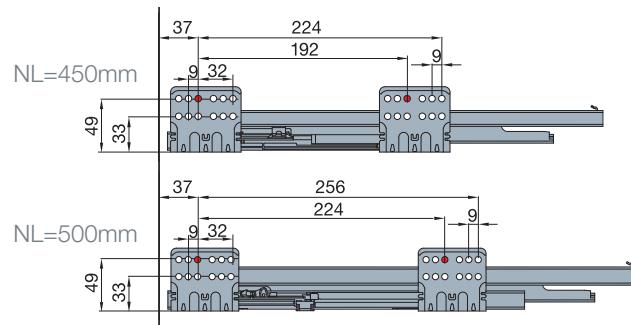
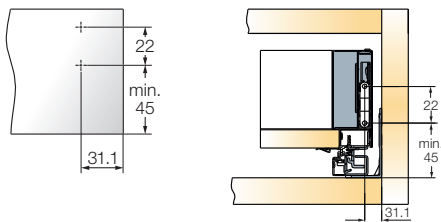

A trial mounting is always recommended.
For further information please contact your Titus Group representative.